

SIEMENS

Built-in
Appliances

Siemens Home Appliances

2022
Collection





Introducing coordinated and intelligently designed appliances by Siemens

Offering you the perfect balance between modern design and innovative technology our range offers different value classes including iQ700; appliances with eye-catching design, cutting-edge technology and large, bright and more intuitive displays. Our iQ500 range brings the latest innovations and sleek designs allowing you to experience first-class appliances in your home. iQ300 and iQ100 offer more affordable options with equally tasteful design and style.

Discover the entire built-in range – for even more flexibility and time-saving solutions which help support increasingly busy lifestyles. Siemens appliances include ovens that save time by speeding up the cooking process with varioSpeed, dishwashers that feature the world’s only Zeolith® drying system; a technological innovation that sets new standards for performance and energy efficiency. In addition our range features fridges with hyperFresh food preservation system to help keep food fresh for longer and outstanding freezers that never have to be defrosted. Not to mention high performance built-in washing machines. All working together to create an outstanding built-in kitchen and utility space in your home.



Stunning design and high quality materials come as standard with all Siemens appliances.

They have been engineered and designed in Germany and give you the satisfaction of Quality, Durability and Reliability.

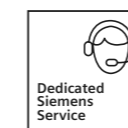

With more than 340 engineers across the UK, all employed and trained by us, our engineers have unrivalled knowledge in repairing our appliances. Each team member goes through over 400 hours of training before attending customer call outs, all for your peace of mind.

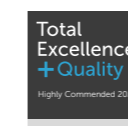

Siemens has been highly commended by D&G for the Total Excellence and Quality award. This award is based on surveys sent to customers of most of the major home appliance manufacturers and confirms our commitment to offering Siemens customers the very best service.



Warranties.



Siemens offer a 2 Year Warranty across the majority of our built-in range for added peace of mind. This warranty covers manufacturing and material faults. To register your warranty please refer to the information on page 175. Our Multi Door / American style fridge freezer and American fridge freezers are the only appliances we currently offer with a 5 Year Warranty.



In addition to the standard manufacturer warranty, our appliances also offer longer warranties on certain parts. This includes a 10 Year Anti-Rust warranty on all dishwashers, a 10 Year Compressor Drive warranty on selected cooling appliances, a 10 Year iQdrive® warranty on selected washing machines and lifetime AquaStop warranty on selected laundry and dishwasher appliances.

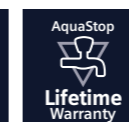

For further details, please refer to page 175 or visit our Siemens Home UK or Ireland website.

Welcome home



The virtualBrochure

You can now experience the entire Siemens range without leaving your house. We have developed an innovative virtualBrochure app which brings the Siemens product range to life, giving you full control of the products, where you can rotate, zoom and interact with every element.

There is also an Augmented Reality feature within the app, that allows you to visualise the range in your own home. Perfect for planning your dream kitchen.

You can download the app from both the Apple Store and Google Play Store.



Download Now



Like and follow us on social media for the latest updates about our products, features and innovations.

Search **SiemensHomeUK** or **SiemensHomeIE**



Or you can also visit our website at siemens-home.bsh-group.com/uk or siemens-home.bsh-group.com/ie to find out more about our products and current offers.

Cooking	10-53
Single ovens with TFT touchDisplay Plus	28-29
Single ovens with TFT touchDisplay	30-31
Single ovens with TFT Display	32-33
Single ovens with lightControl illuminated dials	34-35
Double ovens with lightControl illuminated dials	36-37
Compact ovens with TFT touchDisplay Plus	38-39
Compact ovens with TFT touchDisplay	40-41
Compact ovens with TFT Display	42-43
Compact ovens with lightControl illuminated dials	44-45
Microwaves	46-47
Warming drawers	48
Accessories	49
Coffee centres	50-53
Hobs	54-83
inductionAir Plus hobs	68-69
flexInduction hobs	70-72
Induction hobs	73-75
quickLite ceramic hobs	76-77
Gas hobs	78-81
Domino hobs	82-83
Hoods	84-115
Worktop installation	94-95
Ceiling hoods	96-97
Island hoods	98-99
Decorative hoods	100-101
Box chimney hoods	102-103
Glass chimney hoods	104-105
Pyramid hoods	106-107
Integrated design hoods	108-109
Telescopic hoods	110-111
Integrated hoods	112-113
Canopy hoods	114-115
Cooling	116-147
Wine cabinets	126-127
Multi Door / American Style fridge freezer	128-131
American Style fridge freezers	132-135
Fridge freezers	136-141
Single door fridges and freezers	142-147
Dishwashers	148-163
Fully integrated	160-162
Slimline	163
Home laundry	164-173
Washing machines	170
Washer dryers	172
Services	174-175
Contact us	174
Register your manufacturer's warranty	175

Every connection lets your world grow

Take the next step into the future: Discover how new connections redefine your daily life with Siemens and Home Connect.

To learn more about Home Connect visit siemens-home.bsh-group.com/uk

Open up a world full of exciting possibilities and gain better control over a busy lifestyle: with a range of selected Wi-Fi enabled Home Appliances, you can now also operate your appliances easily and remotely. Use the Home Connect App to access extensive functions and additional partner services – turning your house into a connected home.

Ovens

- **Recipes:** Discover a large and delicious variety of Siemens approved recipes. Select your favourite via the app and send the settings directly to the oven, straight from your mobile, tablet or smart device.
- Operate the oven intuitively from wherever you are, for instance preheat your oven while you are on your way home.

Coffee Centre

- **coffeeWorld:** Explore a wide range of additional coffee specialties from around the world. Select your choice via the app and send the drink instruction straight to your coffee machine.
- **coffeePlaylist:** Impress your guests by asking them to submit their coffee preferences via the app. Transfer the beverage list remotely to the coffee machine and the drinks will be prepared one after the other.
- Operate the coffee machine intuitively from wherever you are, like from your bed when you wake up in the morning, ready for the day ahead.

Hobs and Hoods

- Push notifications are a helpful guide notifying you when your appliance needs maintenance attention, such as letting you know when the filters need replacing.
- **emotionLight Pro:** Change the ambience of the kitchen by changing the light colour of your hood. Choose from up to 256 colours via the Home Connect App, perfect for parties.
- **Cooking assistant:** Use the assist tab on the Home Connect App when using the hob to help you find and select cooking methods. Send the settings directly to your hob for easier and quicker evening meals.
- Conveniently monitor your hob or hood's cooking status, turn appliances on or off or change the cooking settings via the Home Connect App, from wherever you are.

Fridge Freezers

- Manage your appliance remotely and intuitively select and activate the ideal setting for your refrigerator. Whether you are returning from a food shop or boarding a flight, adjust your fridge temperature or setting directly using the app. Receive helpful push notifications directly to your app, such as when you leave the door open.

Dishwashers

- Operate the dishwasher from wherever you are to fit around your lifestyle. Check the washing status, receive push notifications to your mobile such as when the programme has finished, or if the rinse aid needs topping up and even start the machine remotely when out of home.
- **easyStart:** simply select the kind of dishes and your cleaning preference on the app and Home Connect will suggest the correct cycle for your load, making chores stress free and straightforward.

Washing Machines and Tumble Dryers

- Operate laundry appliances from wherever you are and receive push notifications when the cycle is finished.
- **easyStart:** select from 5 easy options via the Home Connect App to identify the best wash or drying setting. Send this cycle type direct from your app to the machine.
- **intelligentDry:** The easiest and fastest way to obtain excellent drying results. Select the washing programme, the load volume of the laundry and the residual moisture level desired. With Home Connect mode enabled, your Siemens washing machine and dryer will communicate with each other. Thanks to intelligent process technology, your washing machine transfers all relevant data to your dryer. Your dryer automatically selects the programme and the most suitable temperature and makes an accurate estimate of the duration of the programme.



Try demo

If you have not yet registered appliances on the app you can still try out the demo function to get a better understanding of the features available to you.

To experience the demo mode use the QR codes to download the free Home Connect app for your device, tap 'add appliances' on the home screen and choose from a range of demo appliances to experiment with.



Apple App Store



Google Play Store



Download and install Home Connect App

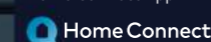

Partners brought to you by Home Connect

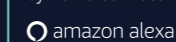

Our world has turned into an ever-growing network of partner services, to help you turn your house into a fully connected home.

Raise your voice and reduce your efforts with Amazon Alexa and Google Assistant.

Food and ambience are equally important when it comes to pleasing your guests, but how can you be in two places at the same time – preparing dishes in the kitchen, whilst entertaining in the living room? Now with Home Connect and the right partner, it just became possible. With just one voice command, you can start the laundry program, preheat the oven, check the dishwashing progress or ask for your favourite coffee. A world of exciting possibilities awaits – just ask your voice assistant.

There are more important things to think of than dishwasher tablets.

Make life easier with Smart Reorder via the Alexa app.

Replenishing consumables is a small thing, but it can also become a big thing when you discover you have just run out of essentials like dishwasher tablets. With Smart Reorder via the Amazon Alexa app, you can experience automatic replenishment. This feature can be set up easily, so you never need to worry about the dishwashing again.

Define your unique with IFTTT.

With IFTTT (If This Then That), you can integrate your Home Connect appliances seamlessly into your life and allow them to communicate with one another, allowing you to create your own automated applets which are perfectly tailored to your needs. Design bespoke triggers, for example, connect your coffee machine to your smart watch and your sleeping rhythm will then be recorded and directly sent to your coffee machine, which can then prepare you the most appropriate morning coffee – a double espresso after a rough night, or a latte after a good rest. There are so many possibilities to be creative; the smart lamp in your living room blinks when the laundry is done, the hood emotionLight lights up when your dinner is ready... Be inspired by checking the IFTTT partner app to learn about the latest "triggers" available.

Manage your appliances while on the run with Fitbit.

Fitbit and Home Connect can help you make sure a warm meal or your favourite cup of coffee is waiting for you after every training session. Thanks to remote control capabilities of the app, you can control your oven, coffee machine, washing machine, washer dryer, tumble dryer and dishwasher, directly from your Fitbit smartwatch. You can also monitor the status of your appliances in real time from your watch, so you can check, for example, how long is left on your washing machine cycle.

Experience the elite studioLine

For those who want to set themselves apart from every standard.

The virtualBrochure.

You can now experience the studioLine range without leaving your house. We have developed an innovative virtualBrochure app which brings the studioLine product range to life, giving you full control of the products, where you can rotate, zoom and interact with every element.

There is also an Augmented Reality feature within the app, that allows you to visualise the range in your own home. Perfect for planning your dream kitchen.

You can download the app from both the Apple Store and Google Play Store.



Download Now

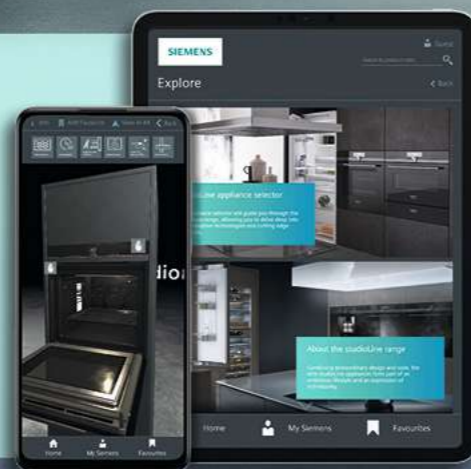

The studioLine kitchen: enjoy elegance and exclusivity with appliances that all line up perfectly to create a guaranteed design statement. Enjoy superior design and cutting-edge functionality in your kitchen. The classic and iconic studioLine appliances with their black glass and blackSteel fascia will complement any high-end kitchen design. The studioLine models all elegantly feature the studioLine signature underneath the Siemens logo.

studioLine offers a complete kitchen solution with innovative technology such as cooking with sous-vide, and cooking without zones on the freeInduction hob.

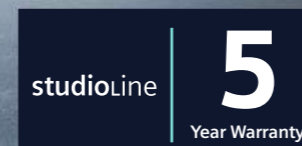

This range is exclusive to studioLine partners. For more information, book online to visit Siemens London, 14 Wigmore Street, London, W1U 2RE at londonshowroom.siemens-home.bsh-group.com or visit our website siemens-home.bsh.com/uk to find a studioLine retailer near you.

A new class of energy efficiency



The new Energy Label, valid from March 2021.

Technological development over the past few years has resulted in a higher concentration of products that were carrying labels with a value of A+ or better. Consequently, the label with the A+++ to D scale had not been fulfilling its original function as an aid for making purchasing decisions as well as it had done formerly. Other basic conditions like user behaviour have also changed. That is why it was time to adapt the energy label. The first appliances to have the new label are washing machines, washer dryers, dishwashers, cooling appliances and wine cabinets. The new label has been appearing on these products since 1st March 2021.

The most significant change in the new energy labels is the elimination of the energy efficiency plus classes, for example A+++. Classification is now from A to G. New methods are also being used for measuring energy consumption and determining the label class. The new specifications take into account real-life usage of the product as much as possible and reflect average consumer behaviour. This means for example, that energy consumption for washing machines, washer dryers and dishwashers is no longer specified by year, but per 100 operating cycles of the particular appliance.

The duration of the label programme to be tested is also specified for these products. In the case of washing machines and washer dryers, there is even a maximum programme duration that must not be exceeded.

The test programme for labelling washing machines and washer-dryers has also changed. The new "Eco 40-60" programme can now be found on the control panel. In addition, these devices now have an even higher washing performance requirement, as well as a minimum requirement for the rinsing effect.

For dishwashers, the components of the standard place setting has also changed to reflect modern usage. For these and other reasons, it is not possible to directly convert the old (A+++ to D) efficiency classes to the new classes.

In addition, you will be able to access further product information directly via a QR code that is displayed on the energy label. The QR code forwards you to a data sheet relating to the appliance.

Look out for the new energy efficiency class icons throughout our brochure and on our product pages.



Sample energy label for dishwashers.

The energy efficiency class for dishwashers continues to be based on the "Eco" programme. However, the test standard has been changed. For example, cups, pots, and plastic utensils will be used to determine cleaning and drying performance to better reflect actual usage behavior.

What is new is the specification of the duration of the Eco programme. This programme is especially eco-friendly, is ideal for normally soiled dishes and is the most efficient programme in the combination "energy and water consumption". As with washing machines and washer dryers, energy consumption will be based on 100 cleaning cycles.

Key

- 1 QR code
- 2 Energy efficiency class
- 3 Energy consumption in kWh/100 operating cycles (in Eco programme)
- 4 Number of standard place settings for the Eco programme
- 5 Water consumption in litres/operating cycle (in Eco programme)
- 6 Duration of the "Eco" programme
- 7 Noise emissions expressed in (dB[A] re 1pW) and noise emission class

The perfect line up. Coordinated and intuitive cooking experiences

From ovens, to warming drawers, to coffee centres. Siemens clean lines and matching appliances allow for perfect design coordination.

Ovens

With stylish design Siemens built-in ovens are designed to impress, ensuring a sleek finish when coordinated with other Siemens appliances. Their ability to be installed independently allows full flexibility to fit appliances under work surfaces, in tall units or in a bank with other appliances. These multiple combinations mean that you have full freedom with your kitchen design, not to mention state-of-the-art technology and features which save you time when cooking.

Compacts

With the variety of appliances in our compact built-in range, Siemens provides a combination of options to suit your preferences, while delivering complete visual perfection. Siemens 45cm and 38cm high compact appliances allow for a full array of cooking experiences. Depending on the range and model, compact ovens are available with steam or integrated microwave, offering space-saving design without compromising on style or utility.



Siemens cooking warranties:



2 Year Warranty

A Two Year Warranty is available on all Siemens ovens and compact appliances listed in this brochure to protect against manufacturing and material faults during this warranty period.

To find out more about your warranty and for registration, please refer to page 175.

Designed to make every day cooking easy



Models shown: CM676GBS6B compact oven, CT636LES6 coffee machine, BI630CNS1B warming drawers, HR678GES6B single oven.

Key features within the iQ700 and iQ500 range



fast preheat

fast preheat

No more tedious waiting for the oven to reach the right temperature.

When you need it, just switch on fast preheating. By activating multiple heating elements simultaneously, Siemens ovens with fast preheating get to the desired temperature very quickly.

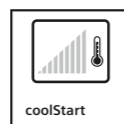

coolStart

coolStart

Cooking certain frozen and chilled foods in the oven is now even faster – thanks to the innovative coolStart function. Without the need to wait for the oven to reach the set temperature, you can successfully cook frozen and chilled foods without preheating, while still using the recommended cooking time.

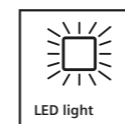

LED light

Everything put in a good light.

Depending on the model, there are different kinds of illumination inside the oven. Whether it is the standard Halogen light, LEDs or the most advanced Multilevel LED strip, they all provide a brilliant view of your dishes without having to open the oven door.



Electronic control

Electronic control

Depending on the function selected, the oven will suggest a suitable temperature which can be manually adjusted. The selected temperature is displayed digitally and a heating up indicator shows the progress towards the set temperature; the same indicator shows residual heat once the oven is turned off. Get quick access to performance features like cookControl and cookControl plus whilst being safe in the knowledge that if left unadjusted for a period of time, the oven will switch off automatically.



Be connected at home to make life easier



With the Home Connect app, you can easily control your Wi-Fi-enabled home appliances from Siemens on your smartphone.

You are in safe hands.

Siemens ovens are equipped with cooking sensors to help you get the best results with your dishes. Use the 'dishes' section on the app and let it suggest the best cooking settings for your dish.

From the app, you can also preheat, control the temperature and find the right baking time easily. Also adjust your oven settings from display to lighting and have your appliance instruction manual always at hand.

The constantly growing network of partner solutions opens up completely new perspectives and networking possibilities for you. For an everyday life that is efficient and exciting like never before.

Browse the recipe section of the Home Connect app and let yourself be inspired by new and selected recipes that meet even the highest demands. Then send the cooking settings of your chosen recipe directly to your oven intuitively from the app.

Every connection lets your world grow.

Connect your Wi-Fi-enabled oven to a wide range of smart devices and services. Check the settings of your device and receive push notifications directly to your phone, like when your oven cooking programme had ended – wherever you are.

Create your own personalised triggers with IFTTT to fit your lifestyle by setting up, for example, an applet where the lights flash in your living room when your meal is ready.

Discover the countless applications that are precisely tailored to your needs. With Home Connect and the relevant partner, you can now control your household with just one click. Create your own personal scenarios by turning off various devices when you want to leave your home. Enjoy the all-in-one solution for intelligent home automation.

Said. Done.

Control your appliances without lifting a finger, just ask your home assistant to start your oven, or even how long it will take until dinner is ready? Control your oven easily by voice - while you relax on the sofa.

Download and install
Home Connect App



Partners brought to you
by Home Connect

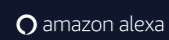



Uncompromising design and technology: iQ700

Introducing features unique to the Siemens iQ700 ovens and compact appliances range.

Thanks to activeClean® and ecoClean® by Siemens, cleaning your oven becomes simple and effortless.



Ovens with activeClean®

Enjoy preparing food without worrying about the consequences. Baked on food and grease can be removed at the push of a button without any need for chemical treatments. Hassle-free, the oven cleans itself thoroughly with activeClean®. It does so by heating up to a very high temperature – turning all residues into ash, which can easily be wiped away. This process is called pyrolysis and is an extremely convenient and efficient way to clean the whole interior of your oven. activeClean® makes it possible to forget about the chore of cleaning your oven and gives you back your time to spend on the things you love.

For iQ700, the telescopic rails and full width enameled pan are specially designed to be used with activeClean® so you do not need to remove them at all. Only the wire shelf needs to be removed.



Ovens with ecoClean®

A special coating applied directly to the inside of the oven (please check specification of individual models), ecoClean® makes cleaning the oven easy. The coated area cleans itself while the oven is on and models with back, roof and side coating benefit from a special cleaning programme.



Cleaning and de-scaling

Finished with a durable enameled interior, most Siemens compact45 combination ovens with steam feature dedicated cleaning and de-scaling programmes.



Drying programme

Select the drying programme after each use to dry residual moisture inside the cavity of the oven.



activeClean® – ovens that clean themselves



Display options available for iQ700 Ovens and Compacts

The iQ700 range has three differing fascia designs each featuring TFT displays with products designed to complement each other and coordinate effortlessly in your kitchen. Thanks to the simple menu structure optimised for convenient and easy-to-use touch navigation, it is even easier to select the perfect settings. Designed to serve one purpose: giving you full control.

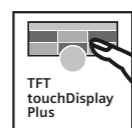

TFT touchDisplay Plus

The TFT touchDisplay Plus offers more than just control of your oven. It gives tips and information on each programme, full colour graphics and images, it can even suggest the correct way to cook your dishes with cookControl Plus. Clear to read from any angle, it is advanced yet easy-to-use technology for effortless cooking.

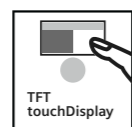

TFT touchDisplay

The slightly smaller TFT touchDisplay offers all the functionality of a touchscreen display with crisp text and images.

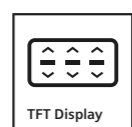

TFT Display

The TFT Display can be operated with touchControl buttons either side of the screen, yet still has clear programme information.

iQ700 appliances display type compatibility

To ensure the best design combination, please refer to the table below to see which compact ovens displays are compatible with which oven displays.

	TFT touchDisplay Plus	TFT touchDisplay	TFT Display
IQ700 SINGLE OVENS			
HN678GES6B	■		
HM678G4S6B	■		
HR678GES6B	■		
HB678GBS6B	■		
HS658GES7B	■		
HM676G0S6B		■	
HR676GBS6B		■	
HB676GBS6B		■	
HM656GNS6B		■	
HB656GBS6B		■	
HB672GBS1B			■
HB632GBS1B			■
IQ700 COMPACT OVENS			
CM678G4S6B	■		
CM676GBS6B		■	
CM656GBS6B		■	
CS656GBS7B		■	
CM633GBS1B			■
CF634AGS1B			■
CD634GAS0B			■

iQ700 ovens and compacts are designed to complement one another.

Whether you are looking for a single oven with an easy clean solution such as activeClean, an oven with steam function or you may be considering an additional compact model with integral microwave to act as a second oven, Siemens has options for every need.

The Siemens compact steamer and steam combination ovens provide the benefit of steam together with perfect design coordination. Steam and added steam cooking has increased in popularity in the past few years. Not only does this offer healthier cooking option as steam retains vitamins and nutrients, but also maintains the visual appearance of many foods.

If coffee is your passion, then why not opt for the Siemens coffee centre – designed to coordinate with the iQ700 range, this versatile machine will provide a variety of specialist coffees at the touch of a button.

The Siemens iQ700 range also includes warming drawers. Primarily designed to pre-heat crockery and keep cooked food warm, these drawers can also slow cook, prove dough and defrost. Available in 14cm or 29cm high options, they combine perfectly with single ovens and 45cm compact models in column or side by side in bank installations. For optimum design coordination, choose iQ700 models with matching TFT displays.



Models shown above: **CM678G4S6B** compact steam combination oven with integral microwave, **BI630CNS1B** warming and accessory drawer and **HM678G4S6B** single multi-function oven



A built-in kitchen assistant.

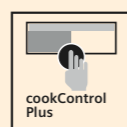

cookControl Plus

Make perfect preparation easier than ever before. Select your chosen dish and enter the weight. The oven will provide tailored setting recommendations for your dish, ensuring you get the best results every time.

This automatic cooking offers up to 70 dish options to ensure meat and fish are cooked to perfection. If you are using a roastingSensor Plus or bakingSensor Plus, cookControl Plus will automatically suggest the mode, time and temperature for your cooking.



The same great results in up to half the time.



varioSpeed

When time is of the essence use the varioSpeed function to cut down your cooking time by up to 50%.

Intuitive to use and a real "allrounder" – for every dish you want to prepare, add the microwave function to your chosen heating mode to enjoy delicious and refined dishes faster.

Get the most out of the ingredients in your creations and receive outstanding results such as soft textures vs. crispy crusts all in record time.

More to explore. Achieve the best results.

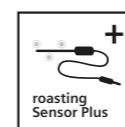

Easier than ever before: roastingSensor Plus

Thanks to three measuring points, the innovative roasting thermometer is able to precisely and reliably measure the core temperature of your dishes. This allows you to use it with a wide range of foods. Ideal for meat, poultry and fish, it can even be combined with the integrated microwave and the pulseSteam function. The roastingSensor Plus removes the need to keep checking your food so you have the freedom to get on with the rest of your cooking.



bakingSensor Plus

Thanks to bakingSensor Plus the oven can detect when the baking process is complete; all that is left for you to do when baking is to prepare the pastry or mix and select the required dish. Innovative sensor technology fitted inside selected iQ700 ovens can automatically control the baking process for consistently delicious baking. The bakingSensor constantly measures the humidity levels in the oven interior and is therefore able to determine when the dish is fully cooked and ready.



Smooth operator.

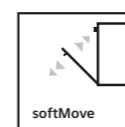

softMove

For effortless operation of the oven door, the dampers ensure gentle and quiet opening every time. Available on all iQ700 built-in ovens.



Model shown: HS658GES7B single oven

Steam cooking. The healthy way to cook.

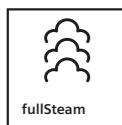

fullSteam

With the Siemens HS658GES7B multifunction fullSteam oven you can prepare delicious and healthy vitamin-rich dishes. Choose the fullSteam option from the 15 different functions and use only hot steam to cook food, which is perfect for rice, fish and vegetables. Therefore food's full flavour, colour, vitamins and minerals are retained whilst cooking without fat or oil. The iQ700 oven is easy to use, even for someone who has never cooked with steam before. fullSteam functionality is also available on Siemens compact oven models CS656GBS7B, CD634GAS0B and iQ500 CP565AGS0B.

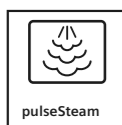

pulseSteam

Siemens ovens and compact appliances with pulseSteam are real all-rounders for more flexibility with your cooking. You can easily add steam while baking and roasting with hot air – with multifunction options you have the perfect cooking method for any food, preserving everything that is important: flavour, smell, texture, vitamins and nutrients. Siemens combi-steam ovens do not just work with hot air but also with top and bottom heating and grilling, so bread, cakes and roasts come out just right: crisp on the outside and moist on the inside.

How does it work?

Siemens steam and steam combination ovens are quick and easy to install as they do not require plumbing-in. Our fullSteam ovens have the temperature range indicated; whereas our pulseSteam models have three intensity levels which can be adjusted, depending on what is being cooked.

The removable 1 litre water tank (1.3 litre for compact steamer) is accessed behind the semi-automatic control panel making it more convenient and easier to refill, even during cooking. Water is heated by a fast and efficient steam generator before being introduced into the oven. Thermostatic controls allow a pure steam temperature of 30 – 100°C.



Model shown: HR678GES6B single oven

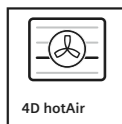

4D hotAir

Be flexible with your cooking. The innovative technology of the fan motor enables optimum heat distribution around the interior of the oven, as the oven is programmed to change the rotating direction of the fan every few minutes. Due to even distribution of heat within the cavity, cooking on up to 4 shelf levels is possible (for compact appliances up to 3 shelves). Your food therefore always turns out perfectly, just as you want it, no matter which shelf you choose to place it on.

Rail Systems: The perfect accessories, designed especially for your iQ700 oven.

We supply accessories that help make cooking easier and more enjoyable for you. Great for tailoring your oven to your individual needs offering ease of use and flexible cooking options to help you create the perfect dish.

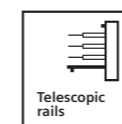

iQ700 telescopic rails

Selected Siemens iQ700 ovens offer a single level, fully extendable telescopic rail¹. Designed to glide smoothly and effortlessly out of the oven, these rails offer clear and comfortable access to tend to your food during cooking and to remove the food once cooked without having to reach into the hot oven. Optional single or triple telescopic rail sets are available for all models in the iQ700 range², including versions suited to pyrolytic models which can remain in the appliance during the cleaning cycle, allowing you to effortlessly clean the oven and the rails at the same time.

¹Please see product descriptions for models that have the rails as standard
²Telescopic rails are not available as optional accessories on ovens with integral microwave



Fixed level telescopic rails



Your time is
precious

Make more of it: iQ500

Get more time for outstanding cooking creations – with a wide range of innovative speed solutions.

Featuring more traditional, yet stylish, illuminated and easy to use control dials, the coordinated lightControl design allows the single ovens, built-in/under double ovens, compact microwave combination ovens, built-in microwave ovens, and warming drawers to be installed together, both vertically and horizontally*.

Siemens offers a choice of two coordinating iQ500 45cm compact microwave combination ovens, each featuring the same striking blue and white lightControl display as the iQ500 single ovens.

The standard microwave combination oven CM585AGS0B features a large 36cm ceramic base to allow for use of rectangular dishes compared to a turntable.

Alternatively, the innovative CP565AGS0B features not only microwave and oven functionality, but also full steam and steam combination options – the ultimate in combination cooking and perfect for maximising your options if space is a premium.

Compact combination ovens are complemented by a 14cm high warming drawer to ensure complete iQ500 design coordination.

If you just need a microwave, the iQ500 range is completed by two design coordinated solo microwaves – a 25L version for installation in tall housing and a smaller 20L model design to fit into 30cm deep wall cupboards.

*Horizontal combinations for single ovens and 45cm compact appliances only.

Operation meets fascination.



lightControl

The lightControl dial highlights the chosen heating symbol with a striking blue light – making operating the oven into an intuitive and exciting experience. The design is consistent throughout the iQ500 range, meaning whether you are selecting a cooking function on a single oven, or introducing steam to the 3 in 1 microwave combination compact appliance, lightControl dials will illuminate whichever function you need.



The secret to perfection.



addedSteam

This feature benefits foods by adding moisture and enhancing colour and crispness. This is done by enhancing a natural process called the Maillard effect. This is a reaction which occurs when natural sugars are caramelized in the presence of heat that gives conventionally cooked food its colour and crispness. Adding shots of steam intensifies this reaction. For example bread crusts become dark, shiny and crisper compared to being cooked by a conventional heat only.

Guarantee the best cooking results:



cookControl

Providing automatic programmes for mainly meat, poultry and fish. Available in either 10 programmes or 30 programmes, simply select the desired dish and enter the food's weight – everything else is done automatically.

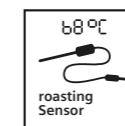

Single point roastingSensor

The roasting thermometer is able to precisely and reliably measure the internal temperature of your dishes. By getting an accurate reading of the core temperature of boneless and fat less dishes, it can determine when they are perfectly done.

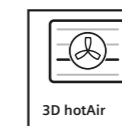

3D hotAir

With the 3D hotAir, you can cook on up to three levels simultaneously. Your oven distributes the heat consistently and guarantees perfect baking results while preventing flavours and smells intermingling.



Model shown:
MB578G5S6B built-in double oven

Introducing Siemens iQ500 double ovens

softClosing Door

Adding to the ambience of any kitchen, the softClosing Door, on selected iQ500 models, closes by gently cushioning the last few centimetres for minimal noise and maximum comfort. In addition, a softClosing Door ensures that items within the appliance are not disturbed from a heavy impact, avoiding unnecessary spills to clean.

iQ500 varioClip rails

Selected Siemens iQ500 single and double ovens¹ feature a pair of innovative varioClip telescopic rails. Intelligently designed with an easy release system, these rails can be unclipped and repositioned on any of the five shelf positions in the oven², allowing you to tailor the position to suit what you are cooking. Whether grilling bacon for breakfast on one of the higher positions, or opting for a lower rail position to cook the Sunday roast, these fully extendable rails perfectly combine flexibility and convenience. Additional pairs of varioClip rails are available as optional extras, allowing you to personalise the rail systems for your oven.



varioClip rails – designed to be released and repositioned quickly and easily

¹ Please see product descriptions for models that have the rails as standard
² varioClip rails suited only to the main oven on double ovens

If you are looking for extra flexibility and more cooking space a Siemens iQ500 double oven is the perfect solution.

Entertain guests with a variety of different foods, baking dessert in the main oven whilst heating savoury dishes within the top oven. Sitting seamlessly within your furniture, kitchen space is maximized without sacrificing the extra cavity space.

Our double oven with activeClean® benefits.

A double oven with top of the range features. Built-in model MB578G5S6B with Home Connect features activeClean® in both the main and top cavity. activeClean® heats up the temperature of the oven to burn residue and allow for easy wipe away cleaning, saving significant time when cleaning the oven. This model also includes the coolStart function, perfect for if you are always on the go and need to heat up frozen and chilled meals quickly.

A built-under to fit beneath work surfaces.

Alternatively the built-under oven model NB535ABS0B with a fast preheat and 3D hotAir cooking available in the main oven cavity, allows you to cook different types of foods flexibly on up to 3 shelving positions, without tastes mingling. Its slightly smaller overall size means this double oven can also fit underneath the work surface – ideal if you require the benefit of two cooking cavities, but are limited for space in your kitchen.



NB535ABS0B built-under double oven

Key features of iQ500 double ovens:



3D hotAir
Can cook all types of food on up to 3 levels simultaneously to stop flavours and smells intermingling.



activeClean®
Heating the cavity up to 480°C, activeClean® burns away all dirt and grime. The remaining ashes can then be easily wiped away making cleaning your oven effortless.



cookControl
Provides automatic programmes for the perfect preparation of meat, fish, vegetables and bread. Simply select the desired dish and enter the food's weight – everything else is done automatically. Either 10 or 30 programmes available, depending on the model.

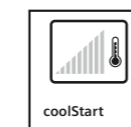

coolStart
No more preheating when cooking chilled and frozen convenience food. Using an intelligent heating phase, it is now possible to cook frozen and chilled food without waiting for the oven to preheat.



fast preheat
By activating all heating elements simultaneously, Siemens ovens with fast preheating get to the desired temperature very quickly.



ecoClean® liners
A direct coating that lines the inside of the oven, ecoClean® makes cleaning the oven easy. The coated area cleans itself while the oven is on or can be activated with a cleaning programme. Available either as a full coating on the back, roof and sides or exclusively on the back panel.



Electronic control
Depending on the function selected, the oven will suggest a suitable temperature which can be manually adjusted. The selected temperature is displayed digitally and a heating up indicator shows the progress towards the set temperature; the same indicator shows residual heat once the oven is turned off. Get quick access to performance features like cookControl whilst being safe in the knowledge that if left unadjusted for a period of time, the oven will switch off automatically.

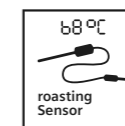

Single point roastingSensor
By getting an accurate reading of the core temperature of boneless and fatless dishes, the roastingSensor can precisely and reliably measure the internal temperature of your dishes to determine when they are perfectly done.

Home Connect

Control your oven simply by using your smartphone or tablet with the Home Connect App.

Features are on selected models. Please check individual models on matrix pages for exact specifications.

Explore compact ovens and microwaves

Ovens with integral microwave*

When teamed with a single oven, Siemens iQ700 compact ovens with microwave offer a great alternative to a double oven if you require more space for traditional cooking. Designed first and foremost to function as an oven, with construction, features and functions identical to a traditional single oven, these models benefit from the addition of microwaves at low medium power (max. 360W) to deliver oven-led combination cooking. Our varioSpeed faster cooking feature speeds up the cooking process while retaining traditional cooking results.

Microwave Combination Ovens*

These iQ500 models are designed to provide more functionality than a solo microwave oven, focussing on combination cooking, with the microwave using higher power (max. 600W) to lead the cooking process, supported by hot air or grill functions to deliver speedy crisp and browned results. Based around a more traditional microwave functionality these models offer the perfect solution if regular microwave heating is the priority, but with the back-up of separate or combination hot air cooking and grill functionality if required.

*These models are designed to operate best in combination mode, so when heating using microwave only, it may be necessary to adjust cooking times.

Compact Ovens with Steam

If you are looking for healthier cooking options the Siemens range of compact ovens with steam allows you to enjoy healthier meals using the power of steam to deliver juicier meats, crisped and fluffy baked items and vegetables that retain more of their vibrant colours, vitamins and nutrients. Siemens fullSteam models offer pure steam cooking, plus many models also offer pulseSteam – pulses of steam are injected into the oven to work in tandem with traditional cooking functions. Please check individual models for exact specifications.



CM676GB56B compact oven with integral microwave



CM585AGS0B compact microwave combination oven



CP565AGS0B compact microwave combination oven with steam

Inverter Technology

Inverter Technology delivers microwave power constantly while cooking – other, traditional microwaves are only able to deliver maximum power and manage the differing settings by alternating between on and off for specific time periods. This can result in uneven heating or over-cooked food and can be especially damaging to more delicate foods or smaller portions.

With Inverter technology, the microwave delivers power constantly, gradually managing the power levels down over time in order to control the food temperature. This gentle approach to cooking reduces uneven heating or overheated food and is especially beneficial for delicate foods. It may be necessary to adjust cooking times to ensure foods are thoroughly cooked before serving. Siemens recommends that the maximum power setting be used for heating liquids and the microwave is calibrated to provide a burst of high power initially, before managing the power down in stages to the next level over the first few minutes.



Models shown: CM678G4S6B iQ700 compact oven with integral microwave and BI630CNS1B iQ700 warming drawer

Warming drawers

Perfect for warming plates, a Siemens warming drawer will keep food warm for latecomers – as well as keeping plates at an optimum temperature to ensure hot food keeps its warmth when plated. With adjustable temperatures of 40-80°C, a four-setting iQ700 14cm or 29cm high warming drawer can be installed as a standalone appliance, or acts as the perfect accompaniment to Siemens iQ700 ovens and compacts. The iQ500 range includes a 14cm high warming drawer featuring 3 settings, minimum, medium and maximum designed to coordinate with Siemens iQ500 ovens and compacts. The perfect line up of an oven, compact appliance with warming drawer is sure to bring style and elegance to any refined kitchen space.



BI630CNS1B iQ700 warming drawer

Single ovens

with TFT touchDisplay Plus

iQ 700 HN678GES6B

Single multi-function oven with integral microwave
Black, stainless steel

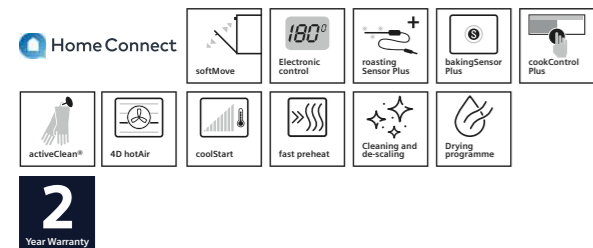

Single ovens with TFT touchDisplay Plus specifications

APPLIANCE TYPE	PYROLYTIC OVEN WITH INTEGRAL MICROWAVE
Design family	iQ 700
Model number	HN678GES6B
DESIGN CHARACTERISTICS	
TFT touchDisplay Plus	■
TFT touchDisplay	-
TFT Display	-
lightControl illuminated dials	-
Central navigation control dial	■
softMove door opening and closing	■
SAFETY FEATURES	
Electronic control	■
Digital temperature display with proposal	■
Heating up indicator/ Residual heat indicator	■ / ■
Control panel lock / Automatic safety switch off	■ / ■
Door lock	■
KEY FEATURES	
Home Connect	■
roastingSensor Plus	■
bakingSensor Plus	■
roastingSensor	-
cookControl Plus	■
cookControl	-
CLEANING FUNCTIONS	
activeClean® pyrolytic oven cleaning	■
Back / roof / side ecoClean® Direct liners	- / - / -
ecoClean® setting	-
PROGRAMMES / FUNCTIONS	
hotAir cooking with hotAir gentle	4D
Microwave (number of combination options)	5
coolStart / fast preheat	■ / ■
Full width surface grill / hotAir grilling / Centre surface grill	■ / ■ / ■
Pizza Setting / Bottom heat / Intensive heat	■ / ■ / ■
Conventional / Conventional gentle	■ / ■
Keep warm / Plate warming	■ / ■
Low temperature cooking / Dehydrate	■ / ■
fullSteam / pulseSteam	- / -
addedSteam	-
Dough proving / Reheating / Defrost	■ / ■ / ■
Descaling programme / Cavity drying function	■ / ■
PERFORMANCE / TECHNICAL INFORMATION	
Product dimensions H x W x D (mm)	595 x 594 x 548
Water tank capacity with empty indicator (litres)	-
Inverter technology	■
Maximum microwave power (W) ² / Number of power levels	800 / 5
Nominal voltage (volts)	220-240
Total connected loading (watts)	3600
Cable length (cm)	120
Minimum fuse protection	16A
Interior lights	Multi Level LED
Door glazing	Quadruple
ENERGY EFFICIENCY DATA¹	
Energy efficiency index	Not applicable
Energy efficiency class	Not applicable
Energy consumption per cycle hotAir (kWh)	Not applicable
Energy consumption per cycle conventional (kWh)	Not applicable
Oven capacity (litres)	67
Time to cook standard load (mins)	Not applicable
Largest baking sheet area (cm)	1290
STANDARD ACCESSORIES	
Full width enamelled pan / Wire shelves	1 / 2
Steam tray, perforated	-
Telescopic rails	1 level

■ Yes, model has this feature. - Feature not available for this model.
¹ According to Regulation (EU) No 65/2014 (models with integral microwave or steam only are exempt).
² For Inverter models, the maximum setting offers a time limited boost option for heating liquids. To ensure optimal results and to protect the appliance, the microwave power output is reduced in stages over the first few minutes down to the next power level (600W). After a cooling period, the microwave boost option will be available once more.
 Data valid in this table as of June 2022. Subject to modification without prior notice.

Single ovens with TFT touchDisplay Plus specifications

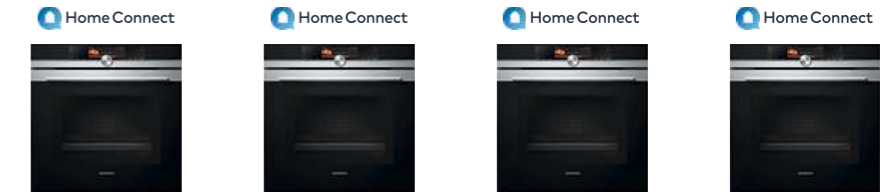

APPLIANCE TYPE	PYROLYTIC OVEN WITH INTEGRAL MICROWAVE	PYROLYTIC OVEN WITH PULSESTEAM	PYROLYTIC OVEN	FULLSTEAM OVEN WITH ECOCLEAN®
Design family	iQ 700	iQ 700	iQ 700	iQ 700
Model number	HM678G456B	HR678GES6B	HB678GS6B	HS658GES7B
DESIGN CHARACTERISTICS				
TFT touchDisplay Plus	■	■	■	■
TFT touchDisplay	-	-	-	-
TFT Display	-	-	-	-
lightControl illuminated dials	-	-	-	-
Central navigation control dial	■	■	■	■
softMove door opening and closing	■	■	■	■
SAFETY FEATURES				
Electronic control	■	■	■	■
Digital temperature display with proposal	■	■	■	■
Heating up indicator/ Residual heat indicator	■ / ■	■ / ■	■ / ■	■ / ■
Control panel lock / Automatic safety switch off	■ / ■	■ / ■	■ / ■	■ / ■
Door lock	■	■	■	■
KEY FEATURES				
Home Connect	■	■	■	■
roastingSensor Plus	■	■	■	■
bakingSensor Plus	■	■	■	■
roastingSensor	-	-	-	-
cookControl Plus	■	■	■	■
cookControl	-	-	-	-
CLEANING FUNCTIONS				
activeClean® pyrolytic oven cleaning	■	■	■	-
Back / roof / side ecoClean® Direct liners	- / - / -	- / - / -	- / - / -	■ / ■ / ■
ecoClean® setting	-	-	-	■
PROGRAMMES / FUNCTIONS				
hotAir cooking with hotAir gentle	4D	4D	4D	4D
Microwave (number of combination options)	5	-	-	-
coolStart / fast preheat	■ / ■	■ / ■	■ / ■	■ / ■
Full width surface grill / hotAir grilling / Centre surface grill	■ / ■ / ■	■ / ■ / ■	■ / ■ / ■	■ / ■ / ■
Pizza Setting / Bottom heat / Intensive heat	■ / ■ / ■	■ / ■ / ■	■ / ■ / ■	■ / ■ / ■
Conventional / Conventional gentle	■ / ■	■ / ■	■ / ■	■ / ■
Keep warm / Plate warming	■ / ■	■ / ■	■ / ■	■ / ■
Low temperature cooking / Dehydrate	■ / ■	■ / ■	■ / ■	■ / ■
fullSteam / pulseSteam	- / -	- / ■	- / -	■ / ■
addedSteam	-	-	-	-
Dough proving / Reheating / Defrost	- / - / -	■ / ■ / -	- / - / -	■ / ■ / ■
Descaling programme / Cavity drying function	- / -	■ / ■	- / -	■ / ■
PERFORMANCE / TECHNICAL INFORMATION				
Product dimensions H x W x D (mm)	595 x 594 x 548	595 x 594 x 548	595 x 594 x 548	595 x 594 x 548
Water tank capacity with empty indicator (litres)	-	1 / ■	-	1 / ■
Inverter technology	■	-	-	-
Maximum microwave power (W) ² / Number of power levels	800 / 5	-	-	-
Nominal voltage (volts)	220-240	220-240	220-240	220-240
Total connected loading (watts)	3600	3600	3600	3450
Cable length (cm)	120	120	120	120
Minimum fuse protection	16A	16A	16A	16A
Interior lights	Multi Level LED	Multi Level LED	Multi Level LED	Multi Level LED
Door glazing	Quadruple	Quadruple	Quadruple	Triple
ENERGY EFFICIENCY DATA¹				
Energy efficiency index	Not applicable	81.2	81.2	81.2
Energy efficiency class	Not applicable	A+	A+	A+
Energy consumption per cycle hotAir (kWh)	Not applicable	0.69	0.69	0.69
Energy consumption per cycle conventional (kWh)	Not applicable	0.87	0.87	0.87
Oven capacity (litres)	67	71	71	71
Time to cook standard load (mins)	Not applicable	44	44	40
Largest baking sheet area (cm)	1290	1290	1290	1290
STANDARD ACCESSORIES				
Full width enamelled pan / Wire shelves	1 / 2	1 / 2	1 / 2	1 / 2
Steam tray, perforated	-	-	-	1 x Small, 1 x Extra large
Telescopic rails	1 level	-	-	-

■ Yes, model has this feature. - Feature not available for this model.
¹ According to Regulation (EU) No 65/2014 (models with integral microwave or steam only are exempt).
² For Inverter models, the maximum setting offers a time limited boost option for heating liquids. To ensure optimal results and to protect the appliance, the microwave power output is reduced in stages over the first few minutes down to the next power level (600W). After a cooling period, the microwave boost option will be available once more.
 Data valid in this table as of June 2022. Subject to modification without prior notice.

Single ovens

with TFT touchDisplay

iQ 700 HM676G0S6B

Single multi-function oven with integral microwave
Black, stainless steel

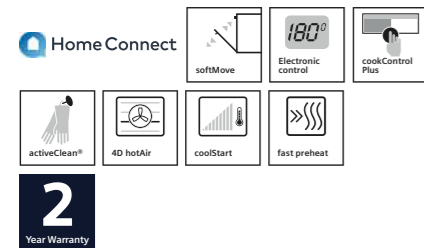

Home Connect



Single ovens with TFT touchDisplay specifications

APPLIANCE TYPE	PYROLYTIC OVEN WITH INTEGRAL MICROWAVE
Design family	iQ 700
Model number	HM676G0S6B
DESIGN CHARACTERISTICS	
TFT touchDisplay Plus	-
TFT touchDisplay	■
TFT Display	-
lightControl illuminated dials	-
Central navigation control dial	■
softMove door opening and closing	■
SAFETY FEATURES	
Electronic control	■
Digital temperature display with proposal	■
Heating up indicator/ Residual heat indicator	■ / ■
Control panel lock / Automatic safety switch off	■ / ■
Door lock	■
KEY FEATURES	
Home Connect	■
roastingSensor Plus	-
bakingSensor Plus	-
roastingSensor	-
cookControl Plus	■
cookControl	-
CLEANING FUNCTIONS	
activeClean® pyrolytic oven cleaning	■
Back / roof / side ecoClean® Direct liners	- / - / -
ecoClean® setting	-
PROGRAMMES / FUNCTIONS	
hotAir cooking with hotAir gentle	4D
Microwave (number of combination options)	5
coolStart / fast preheat	■ / ■
Full width surface grill / hotAir grilling / Centre surface grill	■ / ■ / ■
Pizza Setting / Bottom heat / Intensive heat	■ / ■ / -
Conventional / Conventional gentle	■ / ■
Keep warm / Plate warming	■ / ■
Low temperature cooking / Dehydrate	■ / -
fullSteam / pulseSteam	- / -
addedSteam	-
Dough proving / Reheating / Defrost	- / - / -
Descaling programme / Cavity drying function	- / -
PERFORMANCE / TECHNICAL INFORMATION	
Product dimensions H x W x D (mm)	595 x 594 x 548
Water tank capacity with empty indicator (litres)	-
Inverter technology	■
Maximum microwave power (W) ² / Number of power levels	800 / 5
Nominal voltage (volts)	220-240
Total connected loading (watts)	3600
Cable length (cm)	120
Minimum fuse protection	16A
Interior lights	1 x LED
Door glazing	Quadruple
ENERGY EFFICIENCY DATA¹	
Energy efficiency index	Not applicable
Energy efficiency class	Not applicable
Energy consumption per cycle hotAir (kWh)	Not applicable
Energy consumption per cycle conventional (kWh)	Not applicable
Oven capacity (litres)	67
Time to cook standard load (mins)	Not applicable
Largest baking sheet area (cm)	1290
STANDARD ACCESSORIES	
Full width enamelled pan / Wire shelves	1 / 2
Steam tray, perforated	-
Telescopic rails	1 level

■ Yes, model has this feature. - Feature not available for this model.

¹ According to Regulation (EU) No 65/2014 (models with integral microwave or steam only are exempt).
² For inverter models, the maximum setting offers a time limited boost option for heating liquids. To ensure optimal results and to protect the appliance, the microwave power output is reduced in stages over the first few minutes down to the next power level (600W). After a cooling period, the microwave boost option will be available once more.

Data valid in this table as of June 2022. Subject to modification without prior notice.

Home Connect



Home Connect



Home Connect



Home Connect



Single ovens with TFT touchDisplay specifications

APPLIANCE TYPE	PYROLYTIC OVEN WITH PULSESTEAM	PYROLYTIC OVEN	PYROLYTIC OVEN WITH INTEGRAL MICROWAVE	OVEN WITH ECOCLEAN®
Design family	iQ 700	iQ 700	iQ 700	iQ 700
Model number	HR676G8S6B	HB676G8S6B	HM656GNS6B	HB656G8S6B
DESIGN CHARACTERISTICS				
TFT touchDisplay Plus	-	-	-	-
TFT touchDisplay	■	■	■	■
TFT Display	-	-	-	-
lightControl illuminated dials	-	-	-	-
Central navigation control dial	■	■	■	■
softMove door opening and closing	■	■	■	■
SAFETY FEATURES				
Electronic control	■	■	■	■
Digital temperature display with proposal	■	■	■	■
Heating up indicator/ Residual heat indicator	■ / ■	■ / ■	■ / ■	■ / ■
Control panel lock / Automatic safety switch off	■ / ■	■ / ■	■ / ■	■ / ■
Door lock	■	■	-	-
KEY FEATURES				
Home Connect	■	■	■	■
roastingSensor Plus	-	-	-	-
bakingSensor Plus	-	-	-	-
roastingSensor	-	-	-	-
cookControl Plus	■	■	■	■
cookControl	-	-	-	-
CLEANING FUNCTIONS				
activeClean® pyrolytic oven cleaning	■	■	-	-
Back / roof / side ecoClean® Direct liners	- / - / -	- / - / -	■ / ■ / ■	■ / ■ / ■
ecoClean® setting	-	-	■	■
PROGRAMMES / FUNCTIONS				
hotAir cooking with hotAir gentle	4D	4D	4D	4D
Microwave (number of combination options)	-	-	5	-
coolStart / fast preheat	■ / ■	■ / ■	■ / ■	■ / ■
Full width surface grill / hotAir grilling / Centre surface grill	■ / ■ / ■	■ / ■ / ■	■ / ■ / ■	■ / ■ / ■
Pizza Setting / Bottom heat / Intensive heat	■ / ■ / -	■ / ■ / -	■ / ■ / -	■ / ■ / -
Conventional / Conventional gentle	■ / ■	■ / ■	■ / ■	■ / ■
Keep warm / Plate warming	■ / ■	■ / ■	■ / ■	■ / ■
Low temperature cooking / Dehydrate	■ / -	■ / -	■ / -	■ / -
fullSteam / pulseSteam	- / ■	- / -	- / -	- / -
addedSteam	-	-	-	-
Dough proving / Reheating / Defrost	■ / ■ / -	- / - / -	- / - / -	- / - / -
Descaling programme / Cavity drying function	■ / ■	- / -	- / -	- / -
PERFORMANCE / TECHNICAL INFORMATION				
Product dimensions H x W x D (mm)	595 x 594 x 548	595 x 594 x 548	595 x 594 x 548	595 x 594 x 548
Water tank capacity with empty indicator (litres)	1 / ■	-	-	-
Inverter technology	-	-	■	-
Maximum microwave power (W) ² / Number of power levels	-	-	800 / 5	-
Nominal voltage (volts)	220-240	220-240	220-240	220-240
Total connected loading (watts)	3600	3600	3600	3600
Cable length (cm)	120	120	120	120
Minimum fuse protection	16A	16A	16A	16A
Interior lights	1 x LED	1 x LED	1 x LED	1 x LED
Door glazing	Quadruple	Quadruple	Triple	Triple
ENERGY EFFICIENCY DATA¹				
Energy efficiency index	81.2	81.2	Not applicable	81.2
Energy efficiency class	A+	A+	Not applicable	A+
Energy consumption per cycle hotAir (kWh)	0.69	0.69	Not applicable	0.69
Energy consumption per cycle conventional (kWh)	0.87	0.87	Not applicable	0.87
Oven capacity (litres)	71	71	67	71
Time to cook standard load (mins)	44	44	Not applicable	44
Largest baking sheet area (cm)	1290	1290	1290	1290
STANDARD ACCESSORIES				
Full width enamelled pan / Wire shelves	1 / 2	1 / 2	1 / 2	1 / 2
Steam tray, perforated	-	-	-	-
Telescopic rails	-	-	1 level	-

■ Yes, model has this feature. - Feature not available for this model.

¹ According to Regulation (EU) No 65/2014 (models with integral microwave or steam only are exempt).
² For inverter models, the maximum setting offers a time limited boost option for heating liquids. To ensure optimal results and to protect the appliance, the microwave power output is reduced in stages over the first few minutes down to the next power level (600W). After a cooling period, the microwave boost option will be available once more.

Data valid in this table as of June 2022. Subject to modification without prior notice.

Single ovens

with TFT Display



Model shown: HB672GBS1B single oven

iQ700 HB672GBS1B

Single multi-function oven
Black, stainless steel



2
Year Warranty



Single ovens with
TFT Display specifications



APPLIANCE TYPE	PYROLYTIC OVEN	OVEN WITH ECOCLEAN®
Design family	iQ700	iQ700
Model number	HB672GBS1B	HB632GBS1B
DESIGN CHARACTERISTICS		
TFT touchDisplay Plus	-	-
TFT touchDisplay	-	-
TFT Display	■	■
lightControl illuminated dials	-	-
Central navigation control dial	■	■
softMove door opening and closing	■	■
SAFETY FEATURES		
Electronic control	■	■
Digital temperature display with proposal	■	■
Heating up indicator/ Residual heat indicator	■ / ■	■ / ■
Control panel lock / Automatic safety switch off	■ / ■	■ / ■
Door lock	■	-
KEY FEATURES		
Home Connect	-	-
roastingSensor Plus	-	-
bakingSensor Plus	-	-
roastingSensor	-	-
cookControl Plus	-	-
cookControl	-	-
CLEANING FUNCTIONS		
activeClean® pyrolytic oven cleaning	■	-
Back / roof / side ecoClean® Direct liners	- / - / -	■ / - / -
ecoClean® setting	-	-
PROGRAMMES / FUNCTIONS		
hotAir cooking with hotAir gentle	4D	4D
Microwave (number of combination options)	-	-
coolStart / fast preheat	■ / -	■ / -
Full width surface grill / hotAir grilling / Centre surface grill	■ / ■ / -	■ / ■ / -
Pizza Setting / Bottom heat / Intensive heat	■ / - / -	■ / - / -
Conventional / Conventional gentle	■ / ■	■ / ■
Keep warm / Plate warming	- / -	- / -
Low temperature cooking / Dehydrate	- / -	- / -
fullSteam / pulseSteam	- / -	- / -
addedSteam	-	-
Dough proving / Reheating / Defrost	- / - / -	- / - / -
Descaling programme / Cavity drying function	- / -	- / -
PERFORMANCE / TECHNICAL INFORMATION		
Product dimensions H x W x D (mm)	595 x 594 x 548	595 x 594 x 548
Water tank capacity with empty indicator (litres)	-	-
Inverter technology	-	-
Maximum microwave power (W) ² / Number of power levels	-	-
Nominal voltage (volts)	220-240	220-240
Total connected loading (watts)	3600	3600
Cable length (cm)	120	120
Minimum fuse protection	16A	16A
Interior lights	1 x Halogen	1 x Halogen
Door glazing	Quadruple	Triple
ENERGY EFFICIENCY DATA¹		
Energy efficiency index	81.2	81.2
Energy efficiency class	A+	A+
Energy consumption per cycle hotAir (kWh)	0.69	0.69
Energy consumption per cycle conventional (kWh)	0.87	0.87
Oven capacity (litres)	71	71
Time to cook standard load (mins)	44	44
Largest baking sheet area (cm)	1290	1290
STANDARD ACCESSORIES		
Full width enamelled pan / Wire shelves	1 / 2	1 / 2
Steam tray, perforated	-	-
Telescopic rails	-	-

■ Yes, model has this feature. - Feature not available for this model.

¹ According to Regulation (EU) No 65/2014 (models with integral microwave or steam only are exempt).
² For inverter models, the maximum setting offers a time limited boost option for heating liquids. To ensure optimal results and to protect the appliance, the microwave power output is reduced in stages over the first few minutes down to the next power level (600W). After a cooling period, the microwave boost option will be available once more.

Data valid in this table as of June 2022. Subject to modification without prior notice.

For specification details, please visit siemens-home.bsh-group.com/uk and download a full specification sheet.

For the full range of accessories, please visit our online accessory shop at siemens-home.bsh-group.com/uk/shop or call our Spares Department on 0344 892 8999.

Single ovens

with lightControl illuminated dials

iQ 500 HR578G5S6B

Single multi-function oven with addedSteam
Black, stainless steel

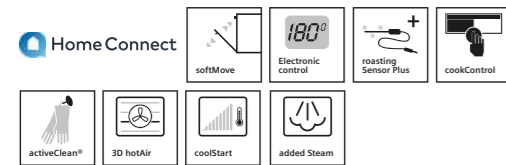

Single ovens with lightControl illuminated dial specifications

APPLIANCE TYPE	PYROLYTIC OVEN WITH ADDED STEAM
Design family	iQ 500
Model number	HR578G5S6B
DESIGN CHARACTERISTICS	
TFT touchDisplay Plus	-
TFT touchDisplay	-
TFT Display	-
lightControl illuminated dials	■
Central navigation control dial	-
softMove door opening and closing	■
SAFETY FEATURES	
Electronic control	■
Digital temperature display with proposal	■
Heating up indicator/ Residual heat indicator	■ / ■
Control panel lock / Automatic safety switch off	■ / ■
Door lock	■
KEY FEATURES	
Home Connect	■
roastingSensor Plus	-
bakingSensor Plus	-
roastingSensor	■
cookControl Plus	-
cookControl	30
CLEANING FUNCTIONS	
activeClean® pyrolytic oven cleaning	■
Back / roof / side ecoClean® Direct liners	- / - / -
ecoClean® setting	-
PROGRAMMES / FUNCTIONS	
hotAir cooking with hotAir gentle	3D
Microwave (number of combination options)	-
coolStart / fast preheat	■ / -
Full width surface grill / hotAir grilling / Centre surface grill	■ / ■ / -
Pizza Setting / Bottom heat / Intensive heat	■ / - / -
Conventional / Conventional gentle	■ / -
Keep warm / Plate warming	- / -
Low temperature cooking / Dehydrate	- / -
fullSteam / pulseSteam	- / -
addedSteam	■
Dough proving / Reheating / Defrost	- / ■ / -
Descaling programme / Cavity drying function	■ / -
PERFORMANCE / TECHNICAL INFORMATION	
Product dimensions H x W x D (mm)	595 x 594 x 548
Water tank capacity with empty indicator (litres)	0.2
Inverter technology	-
Maximum microwave power (W) ² / Number of power levels	-
Nominal voltage (volts)	220-240
Total connected loading (watts)	3600
Cable length (cm)	120
Minimum fuse protection	16A
Interior lights	1 x 25W halogen
Door glazing	Quadruple
ENERGY EFFICIENCY DATA¹	
Energy efficiency index	95.3
Energy efficiency class	A
Energy consumption per cycle hotAir (kWh)	0.81
Energy consumption per cycle conventional (kWh)	0.99
Oven capacity (litres)	71
Time to cook standard load (mins)	51
Largest baking sheet area (cm)	1290
STANDARD ACCESSORIES	
Full width enamelled pan / Wire shelves	1 / 2
Steam tray, perforated	-
Telescopic rails	1 x clip rail

■ Yes, model has this feature. - Feature not available for this model.

¹ According to Regulation (EU) No 65/2014 (models with integral microwave or steam only are exempt).
² For Inverter models, the maximum setting offers a time limited boost option for heating liquids. To ensure optimal results and to protect the appliance, the microwave power output is reduced in stages over the first few minutes down to the next power level (600W). After a cooling period, the microwave boost option will be available once more.

Data valid in this table as of June 2022. Subject to modification without prior notice.

Single ovens with lightControl illuminated dial specifications



APPLIANCE TYPE	PYROLYTIC OVEN	PYROLYTIC OVEN	OVEN WITH ECOCLEAN®
Design family	iQ 500	iQ 500	iQ 500
Model number	HB578G5S6B	HB578A0S6B	HB535A0S0B
DESIGN CHARACTERISTICS			
TFT touchDisplay Plus	-	-	-
TFT touchDisplay	-	-	-
TFT Display	-	-	-
lightControl illuminated dials	■	■	■
Central navigation control dial	-	-	-
softMove door opening and closing	■	-	-
SAFETY FEATURES			
Electronic control	■	■	-
Digital temperature display with proposal	■	■	-
Heating up indicator/ Residual heat indicator	■ / ■	■ / ■	■ / -
Control panel lock / Automatic safety switch off	■ / ■	■ / ■	■ / -
Door lock	■	■	-
KEY FEATURES			
Home Connect	■	■	-
roastingSensor Plus	-	-	-
bakingSensor Plus	-	-	-
roastingSensor	■	-	-
cookControl Plus	-	-	-
cookControl	30	30	10
CLEANING FUNCTIONS			
activeClean® pyrolytic oven cleaning	■	■	-
Back / roof / side ecoClean® Direct liners	- / - / -	- / - / -	■ / - / -
ecoClean® setting	-	-	-
PROGRAMMES / FUNCTIONS			
hotAir cooking with hotAir gentle	3D	3D	3D
Microwave (number of combination options)	-	-	-
coolStart / fast preheat	■ / -	■ / -	■ / -
Full width surface grill / hotAir grilling / Centre surface grill	■ / ■ / -	■ / ■ / -	■ / ■ / -
Pizza Setting / Bottom heat / Intensive heat	■ / - / -	■ / - / -	- / - / -
Conventional / Conventional gentle	■ / -	■ / -	■ / -
Keep warm / Plate warming	- / -	- / -	- / -
Low temperature cooking / Dehydrate	■ / -	■ / -	- / -
fullSteam / pulseSteam	- / -	- / -	- / -
addedSteam	-	-	-
Dough proving / Reheating / Defrost	- / - / -	- / - / -	- / - / -
Descaling programme / Cavity drying function	- / -	- / -	- / -
PERFORMANCE / TECHNICAL INFORMATION			
Product dimensions H x W x D (mm)	595 x 594 x 548	595 x 594 x 548	595 x 594 x 548
Water tank capacity with empty indicator (litres)	-	-	-
Inverter technology	-	-	-
Maximum microwave power (W) ² / Number of power levels	-	-	-
Nominal voltage (volts)	220-240	220-240	220-240
Total connected loading (watts)	3600	3600	3600
Cable length (cm)	120	120	120
Minimum fuse protection	16A	16A	16A
Interior lights	1 x 25W halogen	1 x 25W halogen	1 x 25W halogen
Door glazing	Quadruple	Quadruple	Double
ENERGY EFFICIENCY DATA¹			
Energy efficiency index	95.3	95.3	95.3
Energy efficiency class	A	A	A
Energy consumption per cycle hotAir (kWh)	0.81	0.81	0.81
Energy consumption per cycle conventional (kWh)	0.99	0.99	0.97
Oven capacity (litres)	71	71	71
Time to cook standard load (mins)	50	50	44
Largest baking sheet area (cm)	1290	1290	1290
STANDARD ACCESSORIES			
Full width enamelled pan / Wire shelves	1 / 2	1 / 2	1 / 2
Steam tray, perforated	-	-	-
Telescopic rails	1 x clip rail	1 x clip rail	1 x clip rail

■ Yes, model has this feature. - Feature not available for this model.

¹ According to Regulation (EU) No 65/2014 (models with integral microwave or steam only are exempt).
² For Inverter models, the maximum setting offers a time limited boost option for heating liquids. To ensure optimal results and to protect the appliance, the microwave power output is reduced in stages over the first few minutes down to the next power level (600W). After a cooling period, the microwave boost option will be available once more.

Data valid in this table as of June 2022. Subject to modification without prior notice.

Double ovens

with lightControl illuminated dials



iQ500 MB578G5S6B

Single oven with activeClean®
Black, stainless steel

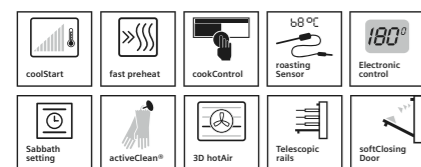

Double ovens with lightControl illuminated dial specifications

APPLIANCE TYPE	BUILT-IN	
	iQ500	
Display family	iQ500	
Model number	MB578G5S6B	
DESIGN CHARACTERISTICS	MAIN	2ND
Black glass with steel trim	■	■
Glass and metal fascia	■	■
lightControl illuminated dials	■	■
Standard bar handle	■	■
Telescopic shelf rail	1 x varioClip	–
SAFETY FEATURES	MAIN	2ND
Electronic control	■	■
Digital temperature display with proposal	■	–
Actual temperature display	■	–
Heating up indicator	■	■
Residual heat indicator	■	■
Control panel lock	■	■
Automatic safety switch off	■	–
Automatic on/off programmer	■	–
FEATURES	MAIN	2ND
Home Connect	■	■
cookControl	30	–
roastingSensor	■	–
CLEANING SYSTEM	MAIN	2ND
Pyrolytic cleaning	■	■
Back / roof / side ecoClean® liners	–	–
ecoClean® setting	–	–
PROGRAMMES / FUNCTIONS	MAIN	2ND
hotairGentle	■	–
3D hotAir cooking	■	–
Defrosting	–	–
Full width surface grill	■	■
Centre surface grill	–	■
Hot air grilling	■	–
coolStart	■	–
Pizza setting	■	–
Conventional top & bottom heating	■	■
Bottom heat	■	■
Low temperature cooking	■	–
Rapid pre-heating	■	–
FEATURES	MAIN	2ND
Electronic clock timer	■	–
Internal light	1 x 25W halogen	1 x 25W halogen
Smooth enamelled oven interior	■	■
Full glass inner door	■	■
Door glazing	4	4
Number of shelf positions	5	3
softClose door	■	–
PERFORMANCE / TECHNICAL INFORMATION	MAIN	2ND
Cavity dimensions H x W x D (mm)	357 x 480 x 415	166 x 480 x 426
Product dimensions H x W x D (mm)	888 x 594 x 550	
Nominal voltage (V) / Total connected loading (W)	220-240 / 6300	
Cable length (cm) / Minimum Fuse Protection	– / 32A	
ENERGY EFFICIENCY CLASS ¹	MAIN	2ND
Energy efficiency Index	95.3	120.3
Energy efficiency class	A	B
Energy consumption per cycle hot air (kWh)	0.81	–
Energy consumption per cycle conventional (kWh)	0.97	0.83
Oven capacity (litres)	71	34
Time to cook standard load (mins)	44	45
Largest baking sheet area (cm)	1290	1290
STANDARD ACCESSORIES	MAIN	2ND
Full width enamelled pan / wire shelves	1 / 3	

■ Yes, model has this feature. – Feature not available for this model.

¹ According to Regulation (EU) No 65/2014 (models with integral microwave or steam only are exempt)

Data valid in this table as of June 2022. Subject to modification without prior notice.

Double ovens with lightControl illuminated dial specifications



APPLIANCE TYPE	BUILT-IN		BUILT-IN		BUILT-UNDER	
	iQ500		iQ500		iQ500	
Model number	MB557G5S0B		MB535A0S0B		NB535A0S0B	
DESIGN CHARACTERISTICS	MAIN	2ND	MAIN	2ND	MAIN	2ND
Black glass with steel trim	■	■	■	■	■	■
Glass and metal fascia	■	■	■	■	■	■
lightControl illuminated dials	■	■	■	■	■	■
Standard bar handle	■	■	■	■	■	■
Telescopic shelf rail	1 x varioClip	–	1 x varioClip	–	–	–
SAFETY FEATURES	MAIN	2ND	MAIN	2ND	MAIN	2ND
Electronic control	–	–	–	–	–	–
Digital temperature display with proposal	–	–	–	–	–	–
Actual temperature display	–	–	–	–	–	–
Heating up indicator	■	–	■	–	■	–
Residual heat indicator	–	–	–	–	–	–
Control panel lock	■	■	■	■	■	■
Automatic safety switch off	–	–	–	–	–	–
Automatic on/off programmer	■	–	■	–	■	–
FEATURES	MAIN	2ND	MAIN	2ND	MAIN	2ND
Home Connect	–	–	–	–	–	–
cookControl	10	–	10	–	–	–
roastingSensor	■	–	–	–	–	–
CLEANING SYSTEM	MAIN	2ND	MAIN	2ND	MAIN	2ND
Pyrolytic cleaning	–	–	–	–	–	–
Back / roof / side ecoClean® liners	■ / ■ / ■	■ / ■ / ■	■ / – / –	■ / ■ / ■	■ / – / –	■ / ■ / ■
ecoClean® setting	■	–	–	–	–	–
PROGRAMMES / FUNCTIONS	MAIN	2ND	MAIN	2ND	MAIN	2ND
hotairGentle	■	–	■	–	■	–
3D hotAir cooking	■	–	■	–	■	–
Defrosting	–	–	–	–	–	–
Full width surface grill	■	■	■	■	■	■
Centre surface grill	–	–	–	–	–	–
Hot air grilling	■	–	■	–	■	–
coolStart	–	–	–	–	–	–
Pizza setting	■	–	–	–	–	–
Conventional top & bottom heating	■	■	■	■	■	■
Bottom heat	■	■	–	■	–	■
Low temperature cooking	–	–	–	–	–	–
Rapid pre-heating	■	–	■	–	■	–
FEATURES	MAIN	2ND	MAIN	2ND	MAIN	2ND
Electronic clock timer	■	■	■	■	■	■
Internal light	1 x 25W halogen	1 x 25W halogen	1 x 25W halogen	1 x 25W halogen	1 x 25W halogen	1 x 25W halogen
Smooth enamelled oven interior	■	■	■	■	■	■
Full glass inner door	■	■	■	■	■	■
Door glazing	3	3	2	3	2	3
Number of shelf positions	5	3	5	3	3	3
softClose door	■	–	–	–	–	–
PERFORMANCE / TECHNICAL INFORMATION	MAIN	2ND	MAIN	2ND	MAIN	2ND
Cavity dimensions H x W x D (mm)	357 x 480 x 415	166 x 480 x 426	357 x 480 x 415	166 x 480 x 426	237 x 480 x 415	166 x 480 x 426
Product dimensions H x W x D (mm)	–		–		–	
Nominal voltage (V) / Total connected loading (W)	220-240 / 6200		220-240 / 6200		220-240 / 5600	
Cable length (cm) / Minimum Fuse Protection	– / –		– / –		– / –	
ENERGY EFFICIENCY CLASS ¹	MAIN	2ND	MAIN	2ND	MAIN	2ND
Energy efficiency Index	95.3	120.3	95.3	120.3	94.7	120.3
Energy efficiency class	A	B	A	B	A	B
Energy consumption per cycle hot air (kWh)	0.81	–	0.81	–	0.71	–
Energy consumption per cycle conventional (kWh)	0.97	0.83	0.97	0.83	0.80	0.83
Oven capacity (litres)	71	34	71	34	47	34
Time to cook standard load (mins)	44	45	44	45	45	45
Largest baking sheet area (cm)	1290	1290	1290	1290	1290	1290
STANDARD ACCESSORIES	MAIN	2ND	MAIN	2ND	MAIN	2ND
Full width enamelled pan / wire shelves	1 / 3		1 / 3		1 / 2	

Yes, model has this feature. – Feature not available for this model.

¹ According to Regulation (EU) No 65/2014 (models with integral microwave or steam only are exempt)

Data valid in this table as of June 2022. Subject to modification without prior notice.

Compact ovens

with TFT touchDisplay Plus



Model shows: **CM678G4S6B** compact oven with microwave, **BI630CNS1B** 14cm warming drawer, **CT636LES6** coffee centre, and **BI510CNROB** 14cm warming drawer

iQ700 CM678G4S6B

Compact pyrolytic oven with integral microwave
Black, stainless steel



2
Year Warranty



HomeConnect



Compact ovens with TFT touchDisplay Plus specifications

APPLIANCE TYPE	PYROLYTIC OVEN WITH INTEGRAL MICROWAVE
Design family	iQ700
Model number	CM678G4S6B
DESIGN CHARACTERISTICS	
Stainless steel navigation control dial	■
TFT TouchDisplay Plus	■
TFT TouchDisplay	-
TFT Display	-
LCD display with lightControl illuminated dials	-
softMove door opening and closing	■
SAFETY FEATURES	
Electronic control	■
Digital temperature display with proposal	■
Heating up indicator / Residual heat indicator	■ / ■
Control panel lock / Automatic safety switch off	■ / ■
Door lock	■
KEY FEATURES	
Home Connect	■
roastingSensor Plus	■
bakingSensor Plus	■
cookControl	-
cookControl Plus	■
CLEANING FUNCTIONS	
activeClean® pyrolytic oven cleaning	■
Back / roof / side ecoClean® Direct liners	-
ecoClean® setting	-
PROGRAMMES / FUNCTIONS	
hotAir cooking with hotAir gentle	4D
Microwave (number of combination options)	5
coolStart / Pre-heating	■ / ■
Full width surface grill / Hot air grilling / Centre surface grill	■ / ■ / ■
Pizza setting / Bottom heat / Intensive heat	■ / ■ / ■
Conventional / Conventional eco	■ / ■
Low temperature cooking / Keep warm	■ / ■
fullSteam / pulseSteam	- / -
addedSteam	-
Dough proving / Reheating / Defrost	- / - / -
Cleaning & Descaling programme / Drying	- / ■
PERFORMANCE / TECHNICAL INFORMATION	
Product dimensions H x W x D (mm)	455 x 594 x 548
Water tank capacity with empty indicator (litres)	-
Inverter technology	■
Maximum microwave power (W) ¹ / Number of power levels	900 / 5
Nominal voltage (volts)	220-240
Total connected loading (watts)	3600
Cable length (cm)	150
Minimum fuse protection	16A
Interior lights	■
Door glazing	Quadruple
ENERGY EFFICIENCY DATA¹	
Energy efficiency index	-
Energy efficiency class	-
Energy consumption per cycle hotAir (kWh)	-
Energy consumption per cycle conventional (kWh)	-
Oven capacity (litres)	45
Time to cook standard load (mins)	-
Largest baking sheet area (cm)	1290
STANDARD ACCESSORIES	
Full width enamelled pan / Wire shelves	1 / 2
Steam tray, perforated (S,L,XL) / unperforated (S,L,XL)	-
Telescopic rails	1 level

■ Yes, model has this feature. - Feature not available for this model.

¹ According to Regulation (EU) No 65/2014 (models with integral microwave or steam only are exempt).
² For inverter models, the maximum setting offers a time limited boost option for heating liquids. To ensure optimal results and to protect the appliance, the microwave power output is reduced in stages over the first few minutes down to the next power level (600W). After a cooling period, the microwave boost option will be available once more.

Data valid in this table as of June 2022. Subject to modification without prior notice.

For specification details, please visit siemens-home.bsh-group.com/uk and download a full specification sheet.

For the full range of accessories, please visit our online accessory shop at siemens-home.bsh-group.com/uk/shop or call our Spares Department on 0344 892 8999.

Compact ovens

with TFT touchDisplay

iQ 700 CM676GBS6B

Compact pyrolytic oven with integral microwave
Black, stainless steel



2 Year Warranty



Home Connect



Compact ovens with
TFT touchDisplay specifications

APPLIANCE TYPE	PYROLYTIC OVEN WITH INTEGRAL MICROWAVE
Design family	iQ 700
Model number	CM676GBS6B
DESIGN CHARACTERISTICS	
Stainless steel navigation control dial	■
TFT TouchDisplay Plus	-
TFT TouchDisplay	■
TFT Display	-
LCD display with lightControl illuminated dials	-
softMove door opening and closing	■
SAFETY FEATURES	
Electronic control	■
Digital temperature display with proposal	■
Heating up indicator / Residual heat indicator	■ / ■
Control panel lock / Automatic safety switch off	■ / ■
Door lock	■
KEY FEATURES	
Home Connect	■
roastingSensor Plus	-
bakingSensor Plus	-
cookControl	-
cookControl Plus	■
CLEANING FUNCTIONS	
activeClean® pyrolytic oven cleaning	■
Back / roof / side ecoClean® Direct liners	-
ecoClean® setting	-
PROGRAMMES / FUNCTIONS	
hotAir cooking with hotAir gentle	4D
Microwave (number of combination options)	5
coolStart / Pre-heating	■ / ■
Full width surface grill / Hot air grilling / Centre surface grill	■ / ■ / ■
Pizza setting / Bottom heat / Intensive heat	■ / ■ / -
Conventional / Conventional eco	■ / ■
Low temperature cooking / Keep warm	■ / ■
fullSteam / pulseSteam	- / -
addedSteam	-
Dough proving / Reheating / Defrost	- / - / -
Cleaning & Descaling programme / Drying	- / -
PERFORMANCE / TECHNICAL INFORMATION	
Product dimensions H x W x D (mm)	455 x 594 x 548
Water tank capacity with empty indicator (litres)	-
Inverter technology	■
Maximum microwave power (W) ² / Number of power levels	900 / 5
Nominal voltage (volts)	220-240
Total connected loading (watts)	3600
Cable length (cm)	150
Minimum fuse protection	16A
Interior lights	■
Door glazing	Quadruple
ENERGY EFFICIENCY DATA¹	
Energy efficiency index	-
Energy efficiency class	-
Energy consumption per cycle hotAir (kWh)	-
Energy consumption per cycle conventional (kWh)	-
Oven capacity (litres)	45
Time to cook standard load (mins)	-
Largest baking sheet area (cm)	1290
STANDARD ACCESSORIES	
Full width enamelled pan / Wire shelves	1 / 1
Steam tray, perforated (S,L,XL) / unperforated (S,L,XL)	-
Telescopic rails	-

■ Yes, model has this feature. - Feature not available for this model.

¹ According to Regulation (EU) No 65/2014 (models with integral microwave or steam only are exempt).
² For Inverter models, the maximum setting offers a time limited boost option for heating liquids. To ensure optimal results and to protect the appliance, the microwave power output is reduced in stages over the first few minutes down to the next power level (600W). After a cooling period, the microwave boost option will be available once more.

Data valid in this table as of June 2022. Subject to modification without prior notice.

Home Connect



Home Connect



Compact ovens with
TFT touchDisplay specifications

APPLIANCE TYPE	OVEN WITH INTEGRAL MICROWAVE	STEAM COMBINATION OVEN
Design family	iQ 700	iQ 700
Model number	CM656GBS6B	CS656GBS7B
DESIGN CHARACTERISTICS		
Stainless steel navigation control dial	■	■
TFT TouchDisplay Plus	-	-
TFT TouchDisplay	■	■
TFT Display	-	-
LCD display with lightControl illuminated dials	-	-
softMove door opening and closing	■	■
SAFETY FEATURES		
Electronic control	■	■
Digital temperature display with proposal	■	■
Heating up indicator / Residual heat indicator	■ / ■	■ / ■
Control panel lock / Automatic safety switch off	■ / ■	■ / ■
Door lock	-	-
KEY FEATURES		
Home Connect	■	■
roastingSensor Plus	-	-
bakingSensor Plus	-	-
cookControl	-	-
cookControl Plus	■	■
CLEANING FUNCTIONS		
activeClean® pyrolytic oven cleaning	-	-
Back / roof / side ecoClean® Direct liners	■ / ■ / ■	■ / ■ / ■
ecoClean® setting	■	■
PROGRAMMES / FUNCTIONS		
hotAir cooking with hotAir gentle	4D	4D
Microwave (number of combination options)	5	-
coolStart / Pre-heating	■ / ■	■ / ■
Full width surface grill / Hot air grilling / Centre surface grill	■ / ■ / ■	■ / ■ / ■
Pizza setting / Bottom heat / Intensive heat	■ / ■ / -	■ / ■ / -
Conventional / Conventional eco	■ / ■	■ / ■
Low temperature cooking / Keep warm	■ / ■	■ / ■
fullSteam / pulseSteam	- / -	■ / -
addedSteam	-	-
Dough proving / Reheating / Defrost	- / - / -	■ / ■ / ■
Cleaning & Descaling programme / Drying	- / -	■ / -
PERFORMANCE / TECHNICAL INFORMATION		
Product dimensions H x W x D (mm)	455 x 594 x 548	455 x 594 x 548
Water tank capacity with empty indicator (litres)	-	1.0
Inverter technology	■	-
Maximum microwave power (W) ² / Number of power levels	900 / 5	- / -
Nominal voltage (volts)	220-240	220-240
Total connected loading (watts)	3600	3300
Cable length (cm)	150	150
Minimum fuse protection	16A	16A
Interior lights	■	■
Door glazing	Triple	Triple
ENERGY EFFICIENCY DATA¹		
Energy efficiency index	-	81.3
Energy efficiency class	-	A+
Energy consumption per cycle hotAir (kWh)	-	0.61
Energy consumption per cycle conventional (kWh)	-	0.73
Oven capacity (litres)	45	47
Time to cook standard load (mins)	-	41
Largest baking sheet area (cm)	1290	1290
STANDARD ACCESSORIES		
Full width enamelled pan / Wire shelves	1 / 1	1 / 1
Steam tray, perforated (S,L,XL) / unperforated (S,L,XL)	-	S, XL JS
Telescopic rails	-	-

■ Yes, model has this feature. - Feature not available for this model.

¹ According to Regulation (EU) No 65/2014 (models with integral microwave or steam only are exempt).
² For Inverter models, the maximum setting offers a time limited boost option for heating liquids. To ensure optimal results and to protect the appliance, the microwave power output is reduced in stages over the first few minutes down to the next power level (600W). After a cooling period, the microwave boost option will be available once more.

Data valid in this table as of June 2022. Subject to modification without prior notice.

Compact ovens

with TFT Display

iQ 700 CM633GBS1B

Compact oven with integral microwave
Black, stainless steel



2
Year Warranty



Compact ovens with TFT Display specifications



APPLIANCE TYPE	OVEN WITH INTEGRAL MICROWAVE
Design family	iQ 700
Model number	CM633GBS1B
DESIGN CHARACTERISTICS	
Stainless steel navigation control dial	■
TFT TouchDisplay Plus	-
TFT TouchDisplay	-
TFT Display	■
LCD display with lightControl illuminated dials	-
softMove door opening and closing	■
SAFETY FEATURES	
Electronic control	■
Digital temperature display with proposal	■
Heating up indicator / Residual heat indicator	■ / ■
Control panel lock / Automatic safety switch off	■ / ■
Door lock	-
KEY FEATURES	
Home Connect	-
roastingSensor Plus	-
bakingSensor Plus	-
cookControl	14
cookControl Plus	-
CLEANING FUNCTIONS	
activeClean® pyrolytic oven cleaning	-
Back / roof / side ecoClean® Direct liners	- / - / -
ecoClean® setting	-
PROGRAMMES / FUNCTIONS	
hotAir cooking with hotAir gentle	4D
Microwave (number of combination options)	2
coolStart / Pre-heating	- / ■
Full width surface grill / Hot air grilling / Centre surface grill	■ / ■ / ■
Pizza setting / Bottom heat / Intensive heat	- / - / -
Conventional / Conventional eco	- / -
Low temperature cooking / Keep warm	- / -
fullSteam / pulseSteam	- / -
addedSteam	-
Dough proving / Reheating / Defrost	- / - / -
Cleaning & Descaling programme / Drying	- / -
PERFORMANCE / TECHNICAL INFORMATION	
Product dimensions H x W x D (mm)	455 x 594 x 548
Water tank capacity with empty indicator (litres)	-
Inverter technology	■
Maximum microwave power (W) ² / Number of power levels	900 / 5
Nominal voltage (volts)	220-240
Total connected loading (watts)	3600
Cable length (cm)	150
Minimum fuse protection	16A
Interior lights	■
Door glazing	Triple
ENERGY EFFICIENCY DATA¹	
Energy efficiency index	-
Energy efficiency class	-
Energy consumption per cycle hotAir (kWh)	-
Energy consumption per cycle conventional (kWh)	-
Oven capacity (litres)	45
Time to cook standard load (mins)	-
Largest baking sheet area (cm)	1290
STANDARD ACCESSORIES	
Full width enamelled pan / Wire shelves	1 / 1
Steam tray, perforated (S,L,XL) / unperforated (S,L,XL)	-
Telescopic rails	-

■ Yes, model has this feature. - Feature not available for this model.

¹ According to Regulation (EU) No 65/2014 (models with integral microwave or steam only are exempt).
² For Inverter models, the maximum setting offers a time limited boost option for heating liquids. To ensure optimal results and to protect the appliance, the microwave power output is reduced in stages over the first few minutes down to the next power level (600W). After a cooling period, the microwave boost option will be available once more.

Data valid in this table as of June 2022. Subject to modification without prior notice.

Compact ovens with TFT Display specifications



APPLIANCE TYPE	MICROWAVE	STEAMER
Design family	iQ 700	iQ 700
Model number	CF634AGS1B	CD634GAS0B
DESIGN CHARACTERISTICS		
Stainless steel navigation control dial	■	■
TFT TouchDisplay Plus	-	-
TFT TouchDisplay	-	-
TFT Display	■	■
LCD display with lightControl illuminated dials	-	-
softMove door opening and closing	-	■
SAFETY FEATURES		
Electronic control	■	■
Digital temperature display with proposal	-	■
Heating up indicator / Residual heat indicator	- / -	■ / -
Control panel lock / Automatic safety switch off	- / ■	■ / ■
Door lock	-	-
KEY FEATURES		
Home Connect	-	-
roastingSensor Plus	-	-
bakingSensor Plus	-	-
cookControl	7	20
cookControl Plus	-	-
CLEANING FUNCTIONS		
activeClean® pyrolytic oven cleaning	-	-
Back / roof / side ecoClean® Direct liners	- / - / -	- / - / -
ecoClean® setting	-	-
PROGRAMMES / FUNCTIONS		
hotAir cooking with hotAir gentle	-	-
Microwave (number of combination options)	-	-
coolStart / Pre-heating	- / -	- / -
Full width surface grill / Hot air grilling / Centre surface grill	- / - / -	- / - / -
Pizza setting / Bottom heat / Intensive heat	- / - / -	- / - / -
Conventional / Conventional eco	- / -	- / -
Low temperature cooking / Keep warm	- / -	- / -
fullSteam / pulseSteam	- / -	■ / -
addedSteam	-	-
Dough proving / Reheating / Defrost	- / - / -	■ / ■ / ■
Cleaning & Descaling programme / Drying	- / -	■ / -
PERFORMANCE / TECHNICAL INFORMATION		
Product dimensions H x W x D (mm)	455 x 595 x 545	455 x 594 x 548
Water tank capacity with empty indicator (litres)	-	1.3
Inverter technology	■	-
Maximum microwave power (W) ² / Number of power levels	900 / 5	- / -
Nominal voltage (volts)	220-240	220-240
Total connected loading (watts)	1220	1900
Cable length (cm)	150	150
Minimum fuse protection	10A	10A
Interior lights	Side	Standard
Door glazing	Double	Double
ENERGY EFFICIENCY DATA¹		
Energy efficiency index	-	-
Energy efficiency class	-	-
Energy consumption per cycle hotAir (kWh)	-	-
Energy consumption per cycle conventional (kWh)	-	-
Oven capacity (litres)	36	38
Time to cook standard load (mins)	-	-
Largest baking sheet area (cm)	1290	-
STANDARD ACCESSORIES		
Full width enamelled pan / Wire shelves	Glass pan / -	1 / 1
Steam tray, perforated (S,L,XL) / unperforated (S,L,XL)	-	L / L
Telescopic rails	-	-

■ Yes, model has this feature. - Feature not available for this model.

¹ According to Regulation (EU) No 65/2014 (models with integral microwave or steam only are exempt).
² For Inverter models, the maximum setting offers a time limited boost option for heating liquids. To ensure optimal results and to protect the appliance, the microwave power output is reduced in stages over the first few minutes down to the next power level (600W). After a cooling period, the microwave boost option will be available once more.

Data valid in this table as of June 2022. Subject to modification without prior notice.

Compact ovens

with lightControl illuminated dials

iQ 500 CP565AGS0B

Compact oven with microwave and steam combination
Black, stainless steel



2
Year Warranty



Compact ovens with lightControl
illuminated dials specifications



APPLIANCE TYPE	MICROWAVE COMBINATION WITH STEAM
Design family	iQ 500
Model number	CP565AGS0B
DESIGN CHARACTERISTICS	
Stainless steel navigation control dial	-
TFT TouchDisplay Plus	-
TFT TouchDisplay	-
TFT Display	-
LCD display with lightControl illuminated dials	■
softMove door opening and closing	-
SAFETY FEATURES	
Electronic control	■
Digital temperature display with proposal	■
Heating up indicator / Residual heat indicator	■ / -
Control panel lock / Automatic safety switch off	■ / ■
Door lock	-
KEY FEATURES	
Home Connect	-
roastingSensor Plus	-
bakingSensor Plus	-
cookControl	30
cookControl Plus	-
CLEANING FUNCTIONS	
activeClean® pyrolytic oven cleaning	-
Back / roof / side ecoClean® Direct liners	Catalytic Back
ecoClean® setting	-
PROGRAMMES / FUNCTIONS	
hotAir cooking with hotAir gentle	Standard
Microwave (number of combination options)	Multiple
coolStart / Pre-heating	- / -
Full width surface grill / Hot air grilling / Centre surface grill	■ / - / -
Pizza setting / Bottom heat / Intensive heat	- / - / -
Conventional / Conventional eco	- / -
Low temperature cooking / Keep warm	- / -
fullSteam / pulseSteam	■ / -
addedSteam	■
Dough proving / Reheating / Defrost	- / - / -
Cleaning & Descaling programme / Drying	■ / -
PERFORMANCE / TECHNICAL INFORMATION	
Product dimensions H x W x D (mm)	455 x 594 x 545
Water tank capacity with empty indicator (litres)	0.80
Inverter technology	■
Maximum microwave power (W) ² / Number of power levels	1000 / 5
Nominal voltage (volts)	220-240
Total connected loading (watts)	3100
Cable length (cm)	150
Minimum fuse protection	16A
Interior lights	■
Door glazing	Triple
ENERGY EFFICIENCY DATA¹	
Energy efficiency index	-
Energy efficiency class	-
Energy consumption per cycle hotAir (kWh)	-
Energy consumption per cycle conventional (kWh)	-
Oven capacity (litres)	36
Time to cook standard load (mins)	-
Largest baking sheet area (cm)	-
STANDARD ACCESSORIES	
Full width enamelled pan / Wire shelves	Glass tray / -
Steam tray, perforated (S,L,XL) / unperforated (S,L,XL)	5
Telescopic rails	-

■ Yes, model has this feature. - Feature not available for this model.

¹ According to Regulation (EU) No 65/2014 (models with integral microwave or steam only are exempt).
² For Inverter models, the maximum setting offers a time limited boost option for heating liquids. To ensure optimal results and to protect the appliance, the microwave power output is reduced in stages over the first few minutes down to the next power level (600W). After a cooling period, the microwave boost option will be available once more.

Data valid in this table as of June 2022. Subject to modification without prior notice.

Compact ovens with lightControl
illuminated dials specifications



APPLIANCE TYPE	MICROWAVE COMBINATION
Design family	iQ 500
Model number	CM585AGS0B
DESIGN CHARACTERISTICS	
Stainless steel navigation control dial	-
TFT TouchDisplay Plus	-
TFT TouchDisplay	-
TFT Display	-
LCD display with lightControl illuminated dials	■
softMove door opening and closing	-
SAFETY FEATURES	
Electronic control	■
Digital temperature display with proposal	-
Heating up indicator / Residual heat indicator	- / -
Control panel lock / Automatic safety switch off	■ / ■
Door lock	-
KEY FEATURES	
Home Connect	-
roastingSensor Plus	-
bakingSensor Plus	-
cookControl	15
cookControl Plus	-
CLEANING FUNCTIONS	
activeClean® pyrolytic oven cleaning	-
Back / roof / side ecoClean® Direct liners	- / - / -
ecoClean® setting	-
PROGRAMMES / FUNCTIONS	
hotAir cooking with hotAir gentle	Standard
Microwave (number of combination options)	2
coolStart / Pre-heating	- / -
Full width surface grill / Hot air grilling / Centre surface grill	■ / - / -
Pizza setting / Bottom heat / Intensive heat	- / - / -
Conventional / Conventional eco	- / -
Low temperature cooking / Keep warm	■ / -
fullSteam / pulseSteam	- / -
addedSteam	-
Dough proving / Reheating / Defrost	- / - / -
Cleaning & Descaling programme / Drying	- / -
PERFORMANCE / TECHNICAL INFORMATION	
Product dimensions H x W x D (mm)	455 x 594 x 570
Water tank capacity with empty indicator (litres)	-
Inverter technology	-
Maximum microwave power (W) ² / Number of power levels	900 / 5
Nominal voltage (volts)	220-240
Total connected loading (watts)	3350
Cable length (cm)	180
Minimum fuse protection	16A
Interior lights	■
Door glazing	Double
ENERGY EFFICIENCY DATA¹	
Energy efficiency index	-
Energy efficiency class	-
Energy consumption per cycle hotAir (kWh)	-
Energy consumption per cycle conventional (kWh)	-
Oven capacity (litres)	44
Time to cook standard load (mins)	-
Largest baking sheet area (cm)	-
STANDARD ACCESSORIES	
Full width enamelled pan / Wire shelves	- / -
Steam tray, perforated (S,L,XL) / unperforated (S,L,XL)	-
Telescopic rails	-

■ Yes, model has this feature. - Feature not available for this model.

¹ According to Regulation (EU) No 65/2014 (models with integral microwave or steam only are exempt).
² For Inverter models, the maximum setting offers a time limited boost option for heating liquids. To ensure optimal results and to protect the appliance, the microwave power output is reduced in stages over the first few minutes down to the next power level (600W). After a cooling period, the microwave boost option will be available once more.

Data valid in this table as of June 2022. Subject to modification without prior notice.

Microwaves

with TFT Display / touchSlider control

iQ 700 BE634LGS1B

Microwave with grill
Black, stainless steel



2
Year Warranty

Microwave specifications

APPLIANCE TYPE	MICROWAVE WITH GRILL
Design family	iQ 700
Model number	BE634LGS1B
Black glass with steel trim	▪
DESIGN CHARACTERISTICS	
Stainless steel navigation control dial	▪
TFT Display	▪
touchControl	▪
Side opening door	▪
Control panel position	Below, horizontal
CONTROLS	
Electronic control	▪
Automatic programmes	10
Safety switch off	–
PROGRAMMES / FUNCTIONS	
Microwave	▪
Quartz Grill	▪
Microwave / grill combination	▪
FEATURES	
Installation in wall unit / tall housing	▪ / ▪
Full width frameless design	▪
Electronic clock	▪
ClearText Display	▪
Full glass inner door	▪
Glazed door (Quadruple/Triple/Double)	Double
Memory settings	–
Maximum cooking time duration (mins)	90
Electronic door opening	▪
Hinge	Left
Internal light	1 x 2W LED
Stainless steel interior	▪
PERFORMANCE / TECHNICAL INFORMATION	
Cavity H x W x D (mm)	220 x 350 x 270
Appliance dimensions H x W x D (mm)	382 x 594 x 318
Oven capacity (litres)	21
Inverter technology	▪
Maximum Microwave power (W) ¹	900
Number of Microwave power levels	5
Microwave distribution	Stirrer
Turntable diameter (mm)	–
Total connected load (kWh)	1.99
Cable length (cm)	150
GB plug	▪
Minimum fuse protection	10A
STANDARD ACCESSORIES	
Glass pan / Insert grid	1 / 1

▪ Yes, model has this feature. – Feature not available for this model.

¹ For Inverter models, the maximum setting offers a time limited boost option for heating liquids. To ensure optimal results and to protect the appliance, the microwave power output is reduced in stages over the first few minutes down to the next power level (600W). After a cooling period, the microwave boost option will be available once more.

Data valid in this table as of June 2022. Subject to modification without prior notice.



Microwave specifications

APPLIANCE TYPE	MICROWAVES		
Design family	iQ 700	iQ 500	iQ 500
Model number	BF634LGS1B	BF555LMS0B	BF525LMS0B
Black glass with steel trim	▪	▪	▪
DESIGN CHARACTERISTICS			
Stainless steel navigation control dial	▪	–	–
TFT Display	▪	–	–
touchControl	▪	touchSlider	touchSlider
Side opening door	▪	▪	▪
Control panel position	Below, horizontal	Right, vertical	Right, vertical
CONTROLS			
Electronic control	▪	▪	▪
Automatic programmes	–	7	7
Safety switch off	–	▪	▪
PROGRAMMES / FUNCTIONS			
Microwave	Stirrer	▪	▪
Quartz Grill	–	–	–
Microwave / grill combination	1.22	–	–
FEATURES			
Installation in wall unit / tall housing	▪ / ▪	– / ▪	201 x 308 x 282
Full width frameless design	▪	▪	382 x 594 x 317
Electronic clock	▪	▪	20
ClearText Display	▪	LED	–
Full glass inner door	▪	–	800
Glazed door (Quadruple/Triple/Double)	Double	–	5
Memory settings	–	1	Turntable
Maximum cooking time duration (mins)	90	99	255
Electronic door opening	▪	▪	1.27
Hinge	Left	Left	130
Internal light	2 x 2W LED	1 x 3W LED	▪
Stainless steel interior	▪	▪	10A
PERFORMANCE / TECHNICAL INFORMATION			
Cavity H x W x D (mm)	220 x 350 x 270	208 x 328 x 369	201 x 308 x 282
Appliance dimensions H x W x D (mm)	382 x 594 x 318	382 x 594 x 388	382 x 594 x 317
Oven capacity (litres)	21	25	20
Inverter technology	▪	–	–
Maximum Microwave power (W) ¹	900	900	800
Number of Microwave power levels	5	5	5
Microwave distribution	Stirrer	Turntable	Turntable
Turntable diameter (mm)	–	315	255
Total connected load (kWh)	1.22	1.45	1.27
Cable length (cm)	150	130	130
GB plug	▪	▪	▪
Minimum fuse protection	10A	10A	10A
STANDARD ACCESSORIES			
Glass pan / Insert grid	– / –	– / –	– / –

▪ Yes, model has this feature. – Feature not available for this model.

¹ For Inverter models, the maximum setting offers a time limited boost option for heating liquids. To ensure optimal results and to protect the appliance, the microwave power output is reduced in stages over the first few minutes down to the next power level (600W). After a cooling period, the microwave boost option will be available once more.

Data valid in this table as of June 2022. Subject to modification without prior notice.

Warming drawers and accessories

iQ700 BI630DNS1B

Warming drawer
Black, stainless steel

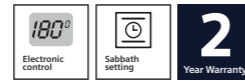
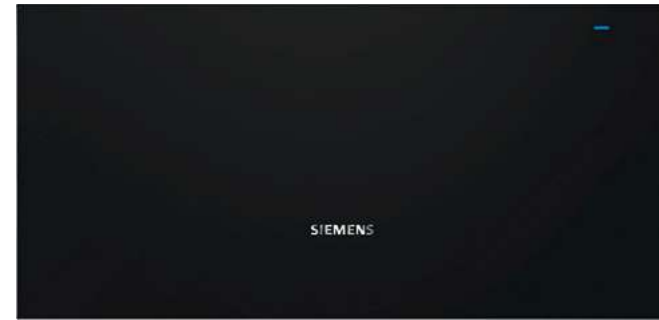

Warming drawers specifications

APPLIANCE TYPE	WARMING DRAWER	WARMING DRAWER	WARMING DRAWER
Model number	BI630DNS1B	BI630CNS1B	BI510CNR0B
Coordinates with	All iQ700 models	All iQ700 models	All iQ500 models
KEY FEATURES & FUNCTIONS			
Operating indicator light	■	■	■
Electronic control	■	■	-
Rotary temperature control dial	■	■	■
Number of temperature settings	4	4	3
Number of vacuum seal time settings	-	-	-
Number of vacuum sealing levels – bags / containers	-	-	-
Glass safety lid	-	-	-
Maximum temperature (C°)	80	80	80
Minimum temperature (C°)	40	40	40
Maximum capacity – plates	40	12	14
Maximum capacity – espresso cups	192	64	64
Toughened glass base	■	■	Anti-slip mat
Vacuum Drawer	-	-	-
Plate warming	■	■	■
Hold Warm	■	■	■
Defrost	■	■	■
Low temperature cooking	■	■	-
TECHNICAL INFORMATION			
Install independently	■	■	■
Install with compact appliance	iQ700	iQ700	iQ500
Install with a single oven	iQ700	iQ700	iQ500
Push-Pull opening mechanism	■	■	■
Drawer interior volume (litres)	52	20	23
Installation in a tall housing	■	■	■
Installation under work surface	■	■	■
Maximum weight capacity (kg)	25	25	15
Total connected loading (kW)	0.81	0.81	0.40
Cable length (in cm)	150	150	150
Appliance Dimensions (H x W x D mm)	242 x 468 x 458	920 x 468 x 458	100 x 475 x 490
Minimum Fuse Protection	10A	10A	6A
GB plug	■	■	■
STANDARD ACCESSORIES			
Vacuuming platform	-	-	-
External vacuuming adaptor, hose & plugs	-	-	-
Sample vacuuming bags	-	-	-
OPTIONAL ACCESSORIES			
100 x Vacuum bags (180 x 280 mm)	-	-	-
100 x Vacuum bags (240 x 350 mm)	-	-	-

■ Yes, model has this feature. – Feature not available for this model.

Data valid in this table as of June 2022. Subject to modification without prior notice.



HZ631010 Colour coordinated full width baking tray with non-stick coating for iQ700 ovens and compacts



HZ915003 5.4L capacity oval glass casserole dish with lid



HZ625071 Two-piece enamelled anti-splash pan insert

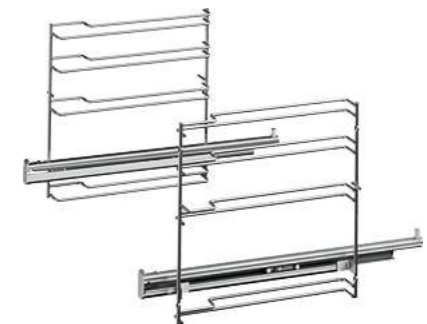

HZ638100 1 level telescopic rails with stop, fully extendible

Optional accessories

	iQ700		iQ500		
	Single Ovens	45cm Compact Ovens	Single Ovens	Compact Ovens	Double Ovens*
ROASTING & BAKING ACCESSORIES					
HZ634000	■	■	■	-	■
HZ664000	■	■	-	-	-
HZ631070	■	■	-	-	-
HZ634080	■	■	-	-	-
HZ531000	-	-	■	-	■
HZ531010	-	-	■	-	■
HZ625071	■	■	■	-	■
HZ636000	■	■	■	-	■
HZ915003	■	■	■	-	■
TELESCOPIC RAILS					
HZ638100	■	-	-	-	-
HZ638170	■	-	-	-	-
HZ638D10	■	-	-	-	-
HZ638D30	■	-	-	-	-
HZ638370	■	-	-	-	-
HZ638300	■	-	■	-	■
HZ538000	-	-	■	-	■
INSTALLATION ACCESSORIES					
HZ68MA00	■	-	-	-	-
HZ66X600	■	-	-	■	-

■ Yes, model has this feature. – Feature not available for this model.

*Main cavity only
Optional accessories not suited for use during pyrolytic cleaning unless stated
Data valid in this table as of June 2022. Subject to modification without prior notice.



Model shown: CT636LES6 built-in coffee centre with TFT touchDisplay

Pure precision for perfect coffee indulgence

Immerse yourself in the world of Siemens coffee.

Kick-start your day or finish it in a relaxed mood in the evening. No matter how or when you prefer to enjoy your coffee Siemens has the right model. Such pleasure is made possible by the interaction of all components – a result of our years of experience and strong commitment to research and development.

Pure precision for perfect coffee indulgence with our built-in coffee machine. Stunningly, uniquely Siemens, our iQ700 built-in coffee centre conveys an elegant impression of absolute quality and intelligent innovation for those passionate about coffee.

The design of the iQ700 coffee centre is perfectly aligned with the entire iQ700 series. To keep the sleek lines looking clean, all milk, water and bean containers are conveniently hidden behind the coffee centre's door, while the TFT touchDisplay and LED lights put each coffee in the spotlight.

Designed with easy access to the water tank, bean holder and insulated milk jug, the coffee centre has front access thanks to a hinged front panel – so you can quickly replace the water or beans. The milk tubes are also cleaned with steam after every coffee with milk and as most of the components are removable and dishwasher safe, they are also easy to clean. Easy to install, the machine requires no extra plumbing.



oneTouch function
No matter what coffee speciality you desire, whether it is a latte macchiato, creamy cappuccino or extra-strong espresso, thanks to the oneTouch Function your fully automatic coffee machine can serve you up pure coffee indulgence at just the touch of a button – it is as easy as that. The system prepares coffee and milk specialities automatically – just how you like them. The perfect technology for a thoroughly indulgent coffee experience.



sensioFlow system
Different coffees require the espresso shot to be heated at a different temperature in order to achieve the perfect results. sensoFlow does this automatically, providing you with a delicious beverage again and again.

Enjoy the wide world of coffee.

With Siemens bean-to-cup coffee machines and Built-in model with Home Connect, you can discover the world of great coffee in just one app: access exclusive coffee drinks and intuitive remote functions directly with a smartphone or tablet.

Home Connect
Explore new coffee beverages, by selecting drinks through the app, design coffee playlists so you and your guests can personalise your own drink preferences and remotely send the order to the machine so they are automatically prepared one after the other.

You can select your coffee with coffeeWorld on your smart device, or ask your voice assistant to make it for you. You will even receive push notifications from your machine, for example, when the beans are running low or when the machine needs cleaning.

Connected partners including Amazon Alexa, allow you to ask your coffee machine to make you a drink just by voice control whilst IFTTT allows you to create bespoke applets so that you can connect your coffee machine to other smart home appliances and create your own personalised routine.

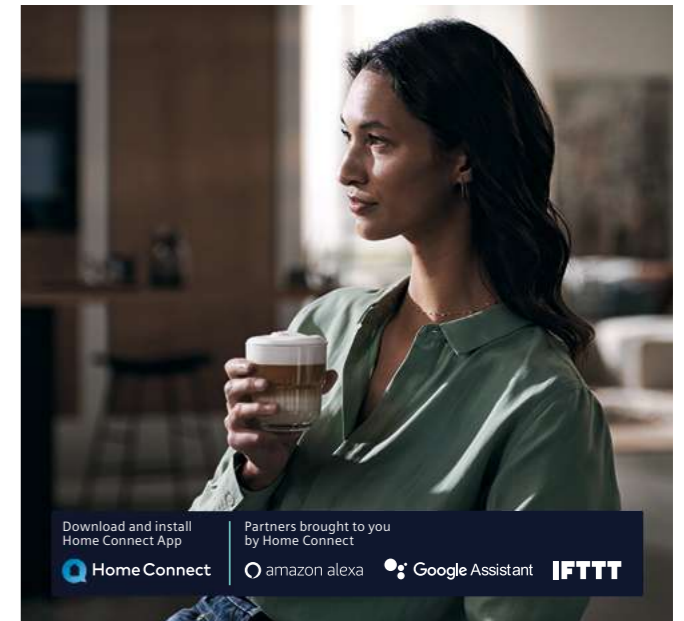

iQ700 CT636LES6

Built-in coffee centre
Black



Home Connect



Built-in coffee centre specifications

APPLIANCE TYPE	COFFEE CENTRES – BUILT-IN
Design family	iQ700
Model number	CT636LES6
TFT touchDisplay	■
KEY FEATURES	
Home Connect	■
Electronic control	■
SensioFlow System	■
Aroma pressure system	■
Auto Valve System	■
AromaDoubleShot	■
Automatic steam blast milk cleaning function	■
One touch preparation	■
Ceramic coffee grinders	■
Multilevel grinding setting	■
Cup illumination	■
Height adjustable coffee & milk outlets (mm)	7-15
Adjustable automatic switch off setting	■
Integrated water filter	■
PROGRAMMES / FUNCTIONS	
my Coffee - personalised beverage settings	1 or 2 cup
Milk foam	1 or 2 cup
Hot water	1 or 2 cup
Warm milk	1 or 2 cup
Ristretto	1 or 2 cup
Coffee	1 or 2 cup
Espresso	1 or 2 cup
Cappuccino	1 or 2 cup
Latte Macchiato	1 or 2 cup
Caffe latte	1 or 2 cup
Espresso Macchiato	1 or 2 cup
One touch function for milk drinks	■
Coffee / Hot water temperature options	3 / 4
Milk foam/frothing function	■ / ■
Warm Milk function	■
Cleaning / descaling / programmes	■ / ■
Automatic rinse when switched on/off	■ / ■
PERFORMANCE / TECHNICAL INFORMATION	
Installation in a tall housing	950-1450mm high
Side opening door (left hinged)	■
Brewing chamber volume (g)	8-12
Bean container capacity (g)	500
Ground coffee container	■
Water tank capacity (litres)	2.4
Total connected loading (W)	1600
Cable length (in cm)	170
STANDARD ACCESSORIES	
Insulated Milk container capacity (litres)	0.5
Milk pipe	■
Coffee measuring spoon	■

■ Yes, model has this feature. – Feature not available for this model.

Data valid in this table as of June 2022. Subject to modification without prior notice.

UnEQualled coffee shop experiences



Model shown: EQ.700 TQ703GB7 bean-to-cup coffee machine

TI9573X9GB

EQ.9 plus, s700 freestanding bean-to-cup coffee machine Piano black and stainless steel

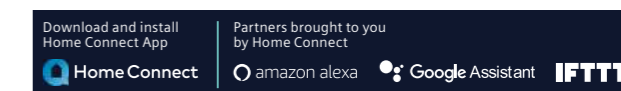
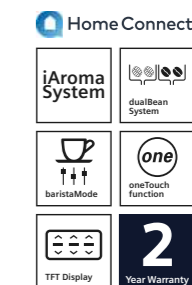

At home. In style

Open your personal coffee bar and enjoy delicious barista-style drinks at home with our EQ freestanding bean-to-cup coffee machines.

Discover the world of cafe culture with the exciting range of EQ fully automatic bean-to-cup coffee machines designed for those that settle for nothing less than exceptional coffee.

With intelligent iAroma technology, 3 key innovations are combined together in a high quality brewing unit to deliver truly sensational tasting beverages. These intuitive appliances stand out on any premium kitchen surface with their stunning design, elegant display panels and optimal usability. From the entry-level compact EQ.3 models to the fine-tuned Wi-Fi-connected EQ.9 model, rediscover your love for outstanding coffee with the Siemens EQ range.

Our top of the range machine: EQ.9 plus, s700

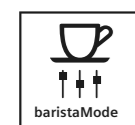

baristaMode: individualise your coffee creation
There are five essential parameters of baristaMode that contribute to the quality of coffee and espresso: coffee strength, amount, temperature, coffee-to-milk ratio and brewing speed. By switching to baristaMode, you can make even finer, fully customised adjustments to please any coffee taste. This optimised setting lets you celebrate the fine art of coffee preparation.

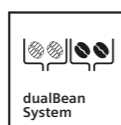

dualBean System: separate bean containers for a pure taste
Two separate coffee bean containers, each with its own grinder, ensure that your beans never get mixed up and guarantee that the desired flavour will always be achieved.



oneTouch DoubleCup
Impress your guests with the simultaneous preparation of two coffee-milk specialities at once. Most of our range has an integrated coffee and milk outlet with double spouts, giving you a little more time to share your delicious coffee with friends.

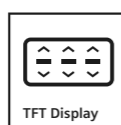

TFT display
With a large, clear and colourful TFT display and disc control manage your drink preference easily and simply with our EQ.9 plus, s700 machine.

Freestanding bean-to-cup coffee machine specifications

	EQ.9		EQ700		EQ500		EQ300	
Model name	EQ9 plus, s700	EQ9, S300	EQ700 classic + fully automatic	EQ.700 int fully automatic	EQ500 integral mid	EQ500 integral low	EQ300 silver	EQ300 black
Model number	TI9573X9GB	TI923309GB	TP705GB1	TQ703GB7	TQ505R09	TQ503GB1	TI353201GB	TI351209GB
FEATURES								
Material / finish	Piano black front, stainless steel body	Piano black front, stainless steel body	Morning haze & black	Inox silver & black	Piano black	Piano black front, stainless steel body	Full lacquer front	Piano black
SensoFlow Heater	■	■	■	■	■	■	■	■
Ceramic grinder	Ceramdrive	Ceramdrive	Ceramdrive	Ceramdrive	Ceramdrive	Ceramdrive	1 x ceramic	1 x ceramic
Milk solution	Integrated	Integrated	Milk Pipe	Integrated	Integrated	Integrated	In cup	In cup
Bean container capacity (g)	270g and 250g	290g	350g	350g	270g	270g	250g	250g
Water tank capacity (litres)	2.3	2.3	2.4	2.4	1.7	1.7	1.4	1.4
One touch drinks	■	■	■	■	■	■	■	■
Removable brewing unit	■	■	■	■	■	■	■	■
Beverage choice	11+	8	18	18	7	7	4	4
Display	TFT	TFT	iSelect Display	iSelect Display	TFT / touch	TFT / touch	Text & symbol	No display
Pump Pressure	19 bar	19 bar	19 bar	19 bar	15 bar	15 bar	15 bar	15 bar
oneTouch DoubleCup	incl. milky drinks	incl. milky drinks	incl. milky drinks	incl. milky drinks	incl. milky drinks	■	■	■
Strength settings	10 + 3	6	4	4	5	5	5	3
Temperature settings	6	3	0	0	3	3	3	3
Cup size settings	-	-	4	4	5	-	-	-
Coffee-milk ratio adjusts	■	■	■	■	-	-	-	-
Noise level	Super silent	Super silent	Quiet	Quiet	Quiet	Quiet	Standard	Standard
Number of bean grinders	2	1	1	1	1	1	1	1
Connectivity	Home Connect	-	Home Connect	Home Connect	-	-	-	-
User Profiles	10	6	10	10	-	-	-	-
Cup warmer	■	-	-	■	-	-	■	■
Bean lid rubber seal	■	■	■	■	■	■	■	■
Brewing unit type	Spindle	Spindle	Spindle	Spindle	Spindle	Spindle	Spindle	Spindle
Service door access	Side	Side	Side	Side	Front	Front	Front	Front
Barista mode	■	-	Aroma Select	Aroma Select	-	-	-	-
Cup illumination	■	■	■	■	■	■	-	-

■ Yes, model has this feature. - Feature not available for this model.

Data valid in this table as of June 2022. Subject to modification without prior notice.

For specification details, please visit siemens-home.bsh-group.com/uk and download a full specification sheet.

For the full range of accessories, please visit our online accessory shop at siemens-home.bsh-group.com/uk/shop or call our Spares Department on 0344 892 8999.

Induction, ceramic and gas hobs. Designed to impress

The Siemens hob range combines stunning design with innovative technology and ergonomic design.

Create a design statement in your kitchen to work in harmony with other Siemens Home appliances. With hob options including distinctive black glass, cooking sensors and Wi-Fi, there are a range of collections including induction, ceramic and gas to choose from.

The advanced technology available in our hobs ensures your cooking experience is as enjoyable as possible, with time-saving features that help you to quickly and effortlessly prepare dishes. With a wide range of styles, sizes and cooking types to suit your needs and kitchen design, we have a hob solution for you.



Model shown: ED851FQ15E
80cm inductionAir glass hob

Siemens
HOB

Siemens hob warranties:

2
Year Warranty

2 Year Warranty

A Two Year Warranty is available on all Siemens hobs listed in this brochure to protect against manufacturing and material faults during this warranty period.

To find out more about your warranty and for registration, please refer to page 175.

Introducing the Siemens hob collection

With intelligent technology, elegant design aesthetic and practical yet impressive functionality, Siemens hobs bring excitement and ease when creating dishes.

Induction cooking



inductionAir Plus venting hobs

The inductionAir Plus venting hobs give you the freedom to design your kitchen how you want to, with the added benefit of hassle-free cleaning. The innovative design means that the grease filters fit into an entirely detachable liquid tray unit which is designed to completely protect against spillages and over-boiled liquids.

Model shown: **ED711FQ15E** (page 69)



flexInduction hobs

Siemens flexInduction hobs are a must for diverse cooking. The cooking area can be tailored to your needs, enabling you to use a small area as traditional induction hobs with four or five separate zones, for boiling rice, for example, or you can choose to link the zones together to form one zone for larger cooking pans.

With flexInduction Plus, your hob automatically knows how large your cookware is. This provides even heat with the use of an additional central zone if the hob detects that the pan is too large.

Model shown: **EX975KXV1E** (page 70)



Induction hobs

Induction cooking is recognised as being one of the quickest, safest and most efficient methods of cooking available. When a pan with a ferrous or magnetic metal base is placed on the hob, the coil situated below the ceramic surface uses an electromagnetic field to create heat, almost instantly heating the pan. With only the base of the pan heated the cooking zone stays cooler.

Model shown: **EH801FVB1E** (page 74)

Ceramic cooking



quickLite hobs

The surface of a glass ceramic hob heats up quickly and conveniently, while also being easy to clean due to the smooth and even surface. The cooking zones glow red when they are on and you can adjust the temperature of the cooking zones precisely, ensured by up to 17 power levels. Siemens highSpeed cooking zones are also optimised for fast cooking and heat up almost instantly.

Model shown: **ET81RBHA1D** (page 76)

Gas cooking



Gas hobs

Tradition meets innovation – with their modern functions, Siemens gas hobs provide enjoyment in cooking like a pro. Low profile, single piece burners on the glass complete the sleek appearance.

Model shown: **ER9A6SB70** (page 78)

Domino cooking



Domino hobs

Domino hobs can be installed alone or side by side with other types of compatible hobs. Domino cooking gives you more cooking options, for example the 40cm wide Teppan Yaki is ideal for combining with other Domino or faceted design cooktops to create a bespoke cooking area.

Models shown: **ET475FYB1E, EX375FXB1E, ER3A6AB70, ER3A6BB70** (pages 82-83)



Model shown:
EX977LXV5E
flexInduction hob
with **HZ390011** roasting dish

Hob Accessories

For additional cooking flexibility Siemens provide a range of accessories for our flexInduction hobs.



Griddle pan

Converts your induction cooktop into a grill, specially designed for use across four flexInductors. The griddle pan maintains an even heat, perfect for frying steak or for roasting meat, fish and vegetables.



Griddle pan
HZ390522



Teppan Yaki

Heating extremely quickly the Teppan Yaki is great for fast Japanese cooking. Perfect for a cooked breakfast or a healthy stir-fry, the pan will fit across either three or four flexInductors.



40x20cm
HZ390512



Roasting dish with steamer

Perfect for use with flexInduction hobs this multipurpose dish is a must when cooking for a crowd. A removable steamer insert is available to compliment this dish and perfect for steaming vegetables.



Roasting dish
HZ390011



Steamer insert
HZ390012

Gas Accessories

Wok ring

Cooking oriental meals in a wok, requires a high temperature. This wok ring helps to regulate heat and concentrate the open flame to one area, giving you the perfect environment for your dish.



Wok ring
17003262

Cross support

Perfect for supporting smaller pots and pans on your hob. Whether you are using an espresso pot, or small saucepan, the cross support will give you maximum stability.



Cross support
00184200

For more details on the range of accessories available please ask your retailer or visit siemens-home.bsh-group.com/uk/shop

Choose the perfect hob for your kitchen

A perfect finish suitable for any modern kitchen.

Siemens aim to provide a wide selection of quality hob choices to ensure there is enough variety and colour-ways to choose from to match your kitchen style.



Black glass



Black ceramic glass



Black tempered glass



Stainless steel



Steel/black glass

Perfectly framed.

When considering an electric hob, you may also be thinking about the look you want to create as well as matching your appliance to other Siemens products. Siemens offers a variety of finishes to the hob frame; from stand out premium steel trims to sleek flushline trims that fit neatly in line with your worktop surface.



Premium steel trim

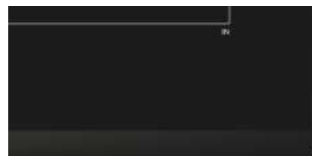

Three sided bevel edge



Flush fit

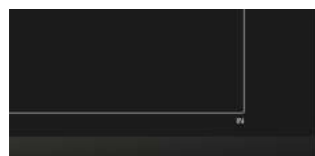

Front bevel

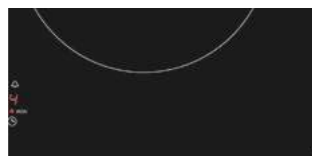

Frameless



The perfect width.

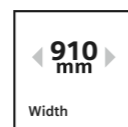

Width

Our hob range is available in a range of widths to suit your kitchen design and needs. Our choice of induction hobs come in 60, 80 and 90cm options, gas is available in 60, 75 and 90cm options and venting hobs come in 60, 70 and 80cm options.

Putting your finger on innovation.



TFT touchDisplay

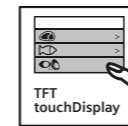

TFT touchDisplay

With the innovative TFT touchDisplay, you can now get the most out of your Siemens induction hob. The full colour touch screen is intuitive and easy to use with clear information about your hob's status at all times as well as additional settings that open up new possibilities. Choose the settings for each individual cooking zone and combine the zones as you like – for example, for different sizes of cookware and various accessories. Access a new world of recipes available through the display screen which can help you cook the perfect dish in just a few simple steps, complete with images and clear text. Take control of your Siemens induction hob and enjoy the advanced design with perfectly prepared meals.

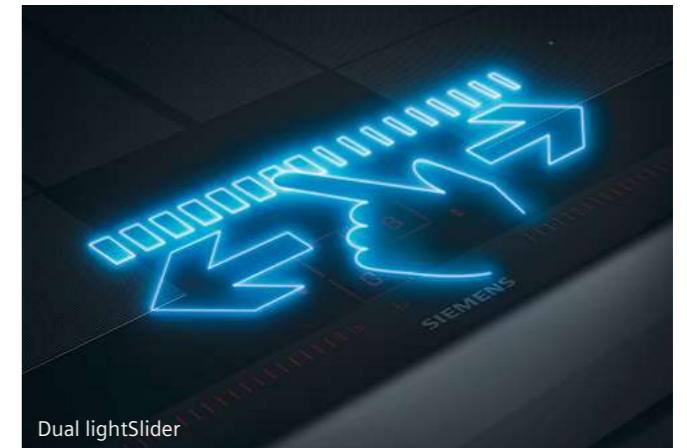

Dual lightSlider

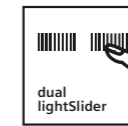

Dual lightSlider

Operate with intuition. The dual lightSlider lets you easily select and join the cooking zones of the iQ700 induction hobs via one neatly arranged interface that illuminates when the hob is turned on. To adjust the power level of the cooking zones simply slide your finger along the lit scale or select the desired power level directly with precise control. When the hob is switched off, the controls are completely invisible for a sleek finish to your kitchen. As there are no protruding parts, cleaning is made even easier.



touchSlider

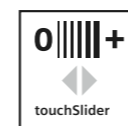

touchSlider

The ergonomic touchSlider sits flush to the appliance and allows you to slide your finger across the power level scale to the desired setting, with control advances in half-levels from 1 to 9. You can also touch the desired level directly for faster adjustments to the cooking zone temperature.



touchControl



touchControl

Thanks to advanced touchControl technology, Siemens hobs can be operated by simply touching the surface. This means the controls are seamlessly integrated into the surface and make cleaning even easier.



frontControl dials

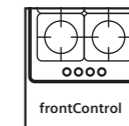

frontControl

Gas hobs with frontControl feature all controls at the front of the appliance for ease of use.

Induction key features

Home Connect Hobs.
Designed to make life easier.

Selected flexInduction hobs are Wi-Fi enabled meaning they can be operated through the Home Connect App with other Siemens products including ovens, hoods and cooling appliances. It is also possible to use the services of different partners – turning your house into a connected home.

For example use voice control with our partner Amazon Alexa to turn your hob on, or change the cooking speed. Use IFTTT to connect our Wi-Fi enabled hobs to a wider variety of partners including home lighting and music systems. Our Home Connect hobs offer you the ability to create a fully connected kitchen for convenience and smart living.

Remote monitoring gives you an overview of your appliance's current status – from wherever you are. Have you ever left the house and had to go back and check if you turned off the hob? Peace of mind is just a click away with Wi-Fi enabled Siemens hobs and the intuitive Home Connect app. You can monitor your appliance's settings including on/off status, active cooking zones, implement child lock and get the cooking time status from wherever you are.

Explore a wide range of recipes via the app and send the cooking and temperature settings straight to your hob. Perfect for busy evenings, find seasonal recipes and extra cooking support through the App.



cookConnect system

Set up this feature through the Home Connect App to control the different functions of the extractor hood directly from your cooktop so you only have to control one appliance when cooking on your hob. From lighting to extractor speed to turning off the appliance, control every aspect of your cookConnect hood directly through your cookConnect hob.

For more information see pages 90 and 91.

Discover more exciting possibilities for a seamless life with Siemens and Home Connect. For more information visit siemens-home.bsh-group.com/uk/homeconnect



Model shown:
EX875KYV1E flexInduction hob



Discover the powerful responsiveness of Siemens induction cooking.

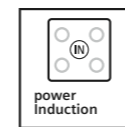

Fast, safe, and easy to clean: powerInduction from Siemens

Instantly hot. Instantly cooler. Experience the benefits of Siemens powerInduction. Heat is conducted directly to the pans and their contents via induction coils, without heating the hob, heat-up times are short, safety is increased and the hob is much easier to clean.

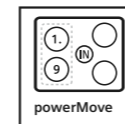

powerMove

Enables intuitive control by splitting the hob into various zones with different set temperatures (low to high). Depending on the hob it has 2, 3 or 5 different zones.



fryingSensor Plus

Makes frying easier by automatically maintaining the ideal temperature to ensure your food is cooked just right. Just select the programme you want depending on the type of food, wait for the signal, add oil to the pan and the food – then fryingSensor Plus takes control.

The integrated fryingSensor Plus gives you full precision when frying by keeping the dish at the defined temperature level as soon as this has been reached.



cookingSensor Plus

No more overboiling. Just attach the sensor to the pot and it will interact with the cooktop, giving a signal when a certain temperature has been reached and keeping it exactly at that level.



The turbocharger for powerInduction: The powerBoost function

Increases power by up to 50%. This can save up to 35% of the time it takes to heat up pots or cook large quantities depending on the chosen dish.



panBoost

Enables you to heat cookware faster than when using heat setting 9. After 30 seconds, this function automatically switches itself off and reverts back to power level 9.

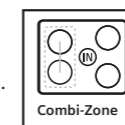

Combi-Zone

Allows you to connect two induction zones together, suitable for larger pots and pans.



powerMove Plus



fryingSensor Plus



cookingSensor Plus

Please note: these features are on selected models. For information on model specification, please check pages 73-75.

Explore the science

of inductionAir Plus
cooking

Model shown:
ED851FQ15E inductionAir Plus hob

Our best induction hob, evolved:
inductionAir Plus



Model shown:
ED851FQ15E inductionAir Plus hob

Evolving the way you cook, the Siemens inductionAir Plus system combines cutting-edge induction technology, such as combi zones and powerMove Plus, with sleek, integrated ventilation. Favoured in open plan and compact kitchens, inductionAir Plus hobs give a sense of free-flowing space and light for a more social experience within the kitchen.

inductionAir Plus hob

The inductionAir Plus hob gives you the freedom to style your kitchen how you want to, with the added benefit of hassle-free cleaning. The innovative design means that the grease filters fit into an entirely detachable liquid tray unit which is made to completely protect against spillages and over-boiled liquids.

How does it work?

All parts of the inductionAir Plus hob are neatly arranged in a liquid tray unit, accessed from the top of the hob. Each part is dishwasher-proof, including the black glass air inlet grid, the 2-in-1 grease filter and the liquid tray. Each part is also separate to save space in your dishwasher.

Protects from spills

As a first layer of protection, the black glass air inlet grid is designed to limit the flow of liquids into the ventilation module. As a second layer of protection, the liquid tray captures up to 200ml from day-to-day cooking and can be easily discarded. In addition, up to 700ml of additional liquid can be held in the liquid safety tank accessed from beneath the appliance, and safe-guarding it from damage. This means you can focus on your cooking with complete peace of mind.

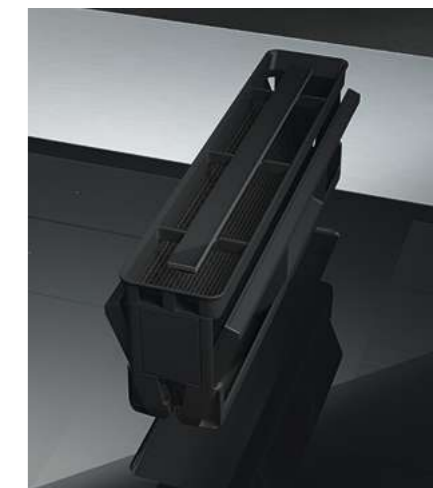

Find the perfect fit for your kitchen.

Size flexibility

The inductionAir Plus hob comes in 3 variants of size: 60cm, 70cm and 80cm. This means that, with whatever space you have, there is an inductionAir Plus hob that will fit perfectly into your kitchen.

Installation options

There are 4 different ways to install the inductionAir Plus hob, giving you plenty of options as to how and where to install it.

See page 9 within the Product installation guide for an outline of installation options and accessory requirements.

flexInduction and induction hobs



Model shown:
EX975KXW1E flexInduction hob

A hob that fits in with your lifestyle, flexInduction is no-compromise cooking at its best.

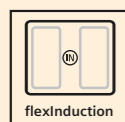

Siemens flexInduction hobs are a must for diverse cooking. The cooking area can be tailored to your needs, enabling you to use as a traditional induction hob with separate zones, or link the zones together for larger cooking pans. The extended cooking surface can accommodate multiple pans of any size, placed anywhere on the surface at the same time. flexInduction also includes boost settings, automatic pan recognition and touchSlider controls.

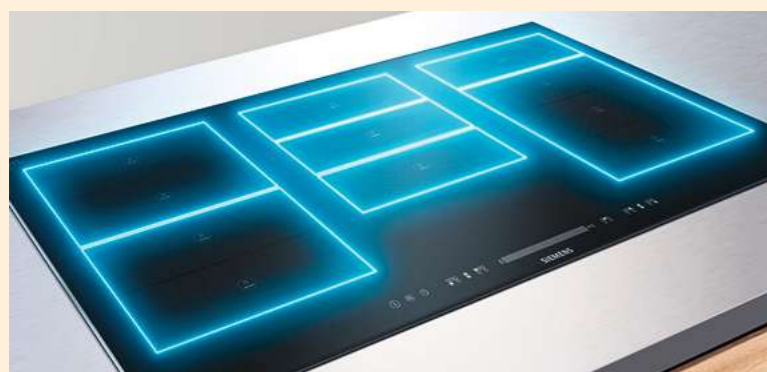

Each flexInduction zone houses four innovative elongated inductors beneath the glass, which act independently to detect the presence of cookware on the hob. The individual inductors only work when cookware is detected, whether that is a 10cm milk pan placed in one corner, or a large griddle plate covering the whole zone. With only specific areas active at any particular time, no energy is wasted. And for an even more versatile cooking, the newly designed triple flexInduction hob provides the ultimate in flexible cooking with three flexInduction zones. flexInduction is no-compromise cooking at its best.

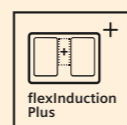

With flexInduction Plus, the cooking zones automatically adapt to the sizes of your pots and pans of up to 30cm in diameter. If one cooking zone is not sufficient, additional inductors are automatically added to ensure the heat is evenly applied at all times. flexInduction Plus offers additional flex zones for even larger pans. In 90cm variants an additional flex zone is possible with additional inductors below the hob surface situated in the centre of the hob. For 80cm flexInduction Plus hobs, the left and right zones can be extended further to allow for a larger cooking space. For 60cm flexInduction Plus hobs, no matter which side of the pan goes over, a central zone is automatically added.

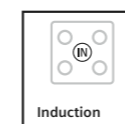

Induction cooking – the cool heat
Induction cooking is recognised as being one of the quickest, safest and most efficient methods of cooking available.

When a pan with a ferrous or magnetic metal base is placed on the hob, the coil situated below the ceramic surface uses an electromagnetic field to create heat, almost instantly heating the pan. With only the base of the pan heated the cooking zone stays cooler.

Easier to clean and safer to use, because the ceramic cooking top is warmed only by the heat transferred back from the cookware and its contents, spillages are less likely to burn on, and there is normally no need to wait for the glass to cool down before simply wiping it over with a cloth, there is some residual heat from the cooking process but there is a reduced risk of burning on high temperatures from the hob surface. And if the induction hob is turned on without a pot or pan being placed on it, the hob itself will not heat up which reduces the risk of burning yourself.

Black glass finish
Our stunning induction hobs feature a black glass finish and bold displays. Our stylish collection mimicks the aesthetics of our built-in ovens and microwaves so your kitchen appliances can truly complement one another.



Model shown:
EX875KYW1E
flexInduction hob

Gas hobs key features

High performance, high speed.

Tradition meets innovation – with their modern functions, Siemens gas hobs provide enjoyment in cooking like a pro. Our top-of-the-range models feature beautiful and durable black ceramic glass hob bases, with cast iron pan supports for a contemporary look. They are designed to coordinate with other appliances in the iQ700 range, and can be combined seamlessly with iQ700 domino and electric hobs. Low profile, single piece burners on the glass complete the sleek appearance.

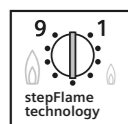
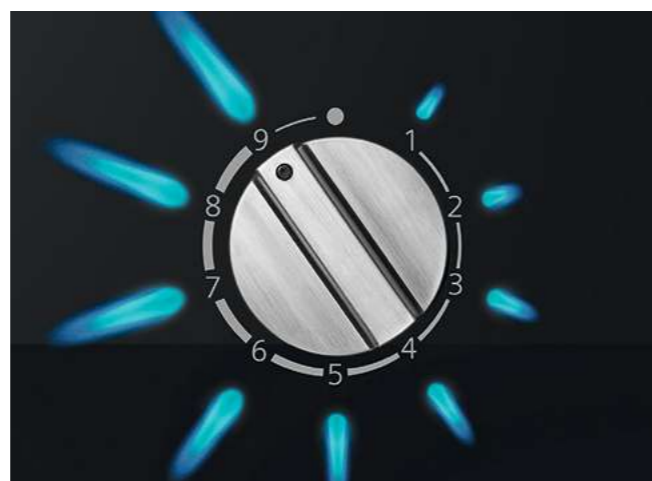

stepFlame technology

Introducing the ground-breaking innovation in gas hobs: stepFlame. Offering 9 precise power levels to give you the control of an electric hob, with gas. No more leaning over to check the flame size, no more hoping that it is at the right heat level. All this guesswork has been removed from cooking with gas. Whatever the level selected, the exact heat and the flame size needed is provided. It is just as easy to operate as it sounds, so conjuring up delicious meals is now easier than ever. It enables you to achieve the precise results you have always dreamt of. Your meals will be delicious, and your guests will be delighted.

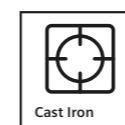

Cast Iron

Cast iron pan supports are designed to withstand even the heaviest of pots and pans and provide a sleek finish to each hob. All can be removed for easier cleaning and iQ700 models have dishwasher safe pan supports.



Wok burner

Siemens gas hobs feature wok burners that deliver 3.3kW, 4.0kW, 4.2kW, 5.0kW or 6.0kW of power depending on the model, meeting the increasing demand for high speed cooking. But it is not just about power; they can be turned down to just 0.3kW – perfect for simmering. For the ultimate in flexibility, our 6.0kW and 5.0kW burners are dual control – the inner and outer flame rings can be adjusted independently via a single control.

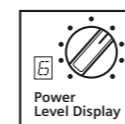

Power Level Display with residual heat indicator

Together with the new stepFlame technology, selected gas hobs feature an LED display which clearly shows the power level you have selected at a glance. For added safety, the LED display also shows whether there is any residual heat from the hob indicated by a capital 'H' for hot and a lower case 'h' for warm.



dishwasher proof

All gas on ceramic glass models feature pan supports that are treated with a special coating which resists discolouration and the damaging effects of a dishwasher.

inductionAir Plus hobs



inductionAir Plus hob specifications

APPLIANCE TYPE		INDUCTIONAIR PLUS HOB	
Design family		IQ500	
Model number		ED851FQ15E	
DESIGN			
Width (mm)		802	
Control type		touchSlider	
Style		front bevel	
KEY FEATURES			
Home Connect		-	
Integrated extractor		■	
Automatic extraction		Auto-On	
cookingSensor Plus ready ¹		-	
fryingSensor Plus		-	
flexInduction zones		-	
powerMove		2 stages	
flexMotion automatic setting transfer		-	
combiZone Induction		2: Left & Right + ventilation	
Digital display		■	
HOB FEATURES			
Number of individual zones		4	
Power levels		17	
powerBoost		■	
Energy consumption display		■	
Quick start		■	
Re-start function		■	
HOOD FEATURES			
Power levels		9 + 2 Intensive	
Automatic intensive revert setting		6 minutes	
Automatic after running: Extraction / Recirculation		12 / 30 minutes	
Dishwasher safe grease filter cassette with spillage collection		Yes – 200ml capacity	
Dishwasher safe spillage overflow collector		700ml capacity	
Electronic grease filter & cleanAir filter saturation indicators		■	
SAFETY FEATURES			
Main on/off switch		■	
Two stage residual heat indicators		■	
Safety lock		■	
Automatic pan recognition		■	
Timed safety switch off		■	
PERFORMANCE / TECHNICAL INFORMATION – HOB			
Nominal voltage (V)		220-240	
Maximum power output (W)		7400	
Electrical cable length (cm)		110	
Rear left zone - power (kW) / dimensions (mm)		2.20	190 x 210
Rear right zone - power (kW) / dimensions (mm)		2.20	190 x 210
Front left zone - power (kW) / dimensions (mm)		2.20	190 x 210
Front right zone - power (kW) / dimensions (mm)		2.20	190 x 210
Flexible Zone left - power (kW) / dimensions (mm)		3.60	380 x 210
Flexible Zone right - power (kW) / dimensions (mm)		3.60	380 x 210
Rear left zone - with powerBoost (max. kW)		3.70	
Rear right zone - with powerBoost (max. kW)		3.70	
Front left zone - with powerBoost (max. kW)		3.70	
Front right zone - with powerBoost (max. kW)		3.70	
PERFORMANCE / TECHNICAL INFORMATION – EXTRACTOR			
Extractor energy efficiency rating		B	
Extraction rate in m ³ /h ^(2,3)			
- ducted / recirculating power level minimum		154 / 150	
- ducted / recirculating power level maximum		500 / 500	
- ducted / recirculating power level intensive		622 / 615	
Noise level (sound power) based on dB[A] re 1pW ^(2,4)			
- ducted / recirculating power level minimum		42 / 41	
- ducted / recirculating power level maximum		69 / 68	
- ducted / recirculating power level intensive		74 / 72	
Motor power (W)		170	
INSTALLATION ACCESSORIES			
Ducted operation using accessory kit		HZ9VEDU0	

■ Yes, model has this feature. – Feature not available for this model.
 All models comply with COMMISSION (EC) No. 1275/2008 with regard to ecodesign requirements for standby and off mode electric power consumption.
¹ Max 3 sensors at any time; one WSP provided.
² Air flow and noise declarations made in line with CECEC Code Of Conduct.
³ Measured according to EN61591 on largest pipe diameter.
⁴ Sound power measured according to EN60704-3 on largest pipe diameter.

Data valid in this table as of June 2022. Subject to modification without prior notice.

IQ500 ED851FQ15E

inductionAir Plus hob
Black glass

80cm

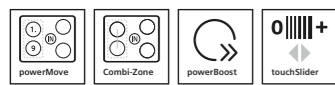

2
Year Warranty



inductionAir Plus hob specifications



APPLIANCE TYPE		INDUCTIONAIR PLUS HOB			
Design family		IQ500		IQ300	
Model number		ED711FQ15E		EH811BE15E	
				EH611BE15E	
DESIGN					
Width (mm)		710		802	
Control type		touchSlider		touchControl	
Style		Frameless		Frameless	
KEY FEATURES					
Home Connect		-		-	
Integrated extractor		■		■	
Automatic extraction		Auto-On		Auto-On	
cookingSensor Plus ready ¹		-		-	
fryingSensor Plus		-		-	
flexInduction zones		-		-	
powerMove		2 stages		-	
flexMotion automatic setting transfer		-		-	
combiZone Induction		2: Left & Right + ventilation		-	
Digital display		■		■	
HOB FEATURES					
Number of individual zones		4		4	
Power levels		17		17	
powerBoost		■		■	
Energy consumption display		■		-	
Quick start		■		■	
Re-start function		■		■	
HOOD FEATURES					
Power levels		9 + 2 Intensive		3 + 1 Intensive	
Automatic intensive revert setting		6 minutes		6 minutes	
Automatic after running: Extraction / Recirculation		12 / 30 minutes		12 / 30 minutes	
Dishwasher safe grease filter cassette with spillage collection		Yes – 200ml capacity		Yes – 200ml capacity	
Dishwasher safe spillage overflow collector		700ml capacity		700ml capacity	
Electronic grease filter & cleanAir filter saturation indicators		■		■	
SAFETY FEATURES					
Main on/off switch		■		■	
Two stage residual heat indicators		■		■	
Safety lock		■		■	
Automatic pan recognition		■		■	
Timed safety switch off		■		■	
PERFORMANCE / TECHNICAL INFORMATION – HOB					
Nominal voltage (V)		220-240		220-240	
Maximum power output (W)		7,400		7,400	
Electrical cable length (cm)		110		110	
Rear left zone - power (kW) / dimensions (mm)		2.20	190 x 210	1.80	180
Rear right zone - power (kW) / dimensions (mm)		2.20	190 x 210	1.80	180
Front left zone - power (kW) / dimensions (mm)		2.20	190 x 210	2.20	210
Front right zone - power (kW) / dimensions (mm)		2.20	190 x 210	2.20	210
Flexible Zone left - power (kW) / dimensions (mm)		3.60	380 x 210		
Flexible Zone right - power (kW) / dimensions (mm)		3.60	380 x 210		
Rear left zone - with powerBoost (max. kW)		3.70		3.10	
Rear right zone - with powerBoost (max. kW)		3.70		3.10	
Front left zone - with powerBoost (max. kW)		3.70		3.70	
Front right zone - with powerBoost (max. kW)		3.70		3.70	
PERFORMANCE / TECHNICAL INFORMATION – EXTRACTOR					
Extractor energy efficiency rating		B		B	
Extraction rate in m ³ /h ^(2,3)					
- ducted / recirculating power level minimum		154 / 150		352 / 332	
- ducted / recirculating power level maximum		500 / 500		500 / 500	
- ducted / recirculating power level intensive		622 / 615		575 / 565	
Noise level (sound power) based on dB[A] re 1pW ^(2,4)					
- ducted / recirculating power level minimum		42 / 41		60 / 58	
- ducted / recirculating power level maximum		69 / 68		68 / 68	
- ducted / recirculating power level intensive		74 / 72		72 / 70	
Motor power (W)		170			
INSTALLATION ACCESSORIES					
Diffuser required for ducted recirculation		HZ9VRPD1		HZ9VRPD1	
Ducted recirculation starter kit for min. 70cm deep worktops.		HZ9VDKR0		HZ9VDKR0	
Ducted recirculation starter kit for min. 60cm deep worktops.		HZ9VDKR1		HZ9VDKR1	
Ducted exhaust starter kit for min. 60cm deep worktops.		HZ9VDKE1		HZ9VDKE1	

■ Yes, model has this feature. – Feature not available for this model.
 All models comply with COMMISSION (EC) No. 1275/2008 with regard to ecodesign requirements for standby and off mode electric power consumption.
¹ Max 3 sensors at any time; one WSP provided.
² Air flow and noise declarations made in line with CECEC Code Of Conduct.
³ Measured according to EN61591 on largest pipe diameter.
⁴ Sound power measured according to EN60704-3 on largest pipe diameter.

Data valid in this table as of June 2022. Subject to modification without prior notice.

flexInduction hobs

iQ700 EX975KXV1E

flexInduction hob
Black glass

90cm

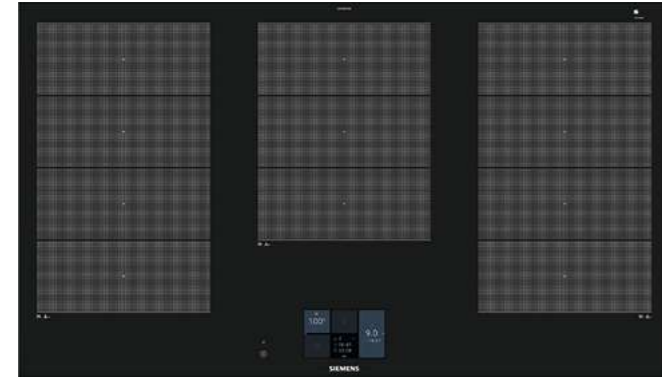

■ Yes, model has this feature. – Feature not available for this model.
All models comply with COMMISSION (EC) No. 1275/2008 with regard to ecodesign requirements for standby and off mode electric power consumption.
¹Max 3 sensors at any time. "Ready" identifies products with feature enabled, sensor available as additional purchase. If sensor is supplied, number supplied is detailed.
²On 60cm model, the single centre aux inductor can work only with either the left or right zones. On the 80cm models, there are two aux inductors, one allocated each to the left and right zones. No bridge is possible to use 2 aux zones together.
³Not compatible with Domino Hobs.
Data valid in this table as of June 2022. Subject to modification without prior notice.



flexInduction hob specifications

APPLIANCE TYPE	FLEXINDUCTION HOB
Design family	iQ700
Model number	EX975KXV1E ¹
Availability	From June 2022
DESIGN	
Width (mm)	912
Control position	Front
Control type	TFT Control
Style	Stainless steel side trim
KEY FEATURES	
Home Connect	■
cookConnect	■
Full Touch colour display with dish categories	■
cookingSensor Plus ready ¹	–
fryingSensor	5 settings
Number of flexInduction zones	3
Extended flexInduction zone ²	–
Number of combiZones	–
powerBoost	■
panBoost	■
powerMove	3 stages
FEATURES	
Number of individual zones	5
Power levels	17
Digital display	■
QuickStart	■
Restart function	■
quickStop	–
flexMotion automatic setting transfer	■
Wipe protection function	■
Keep warm function	■
Energy consumption display	■
Demo mode	■
SAFETY FEATURES	
Main on/off switch	■
Residual heat Indicator	■
Safety lock	■
Timer with automatic switch off for each zone	■
Count up timer / Automatic pan recognition	■ / ■
PERFORMANCE / TECHNICAL INFORMATION	
Nominal voltage (V)	220-240
Maximum power output (W) / Electrical cable length (cm)	11,100 / 110
GB plug	–
One continuous cooking zone – power (kW) / dimensions (mm)	–
One continuous cooking zone – with powerBoost (max. kW)	–
Rear left flexInduction zone – power (kW) / dimensions (mm)	2.20 200 x 240
Rear left zone – power (kW) / diameter (mm)	–
Rear right flexInduction zone – power (kW) / dimensions (mm)	2.20 200 x 240
Rear right zone – power (kW) / diameter (mm)	–
Rear centre zone – power (kW) / diameter (mm)	2.60 300 x 240
Front centre zone – power (kW) / diameter (mm)	–
Front left flexInduction zone – power (kW) / dimensions (mm)	2.20 200 x 240
Front left zone – power (kW) / diameter (mm)	–
Front right flexInduction zone – power (kW) / dimensions (mm)	2.20 200 x 240
Front right zone – power (kW) / diameter (mm)	–
flexInduction Zone left – power (kW) / dimensions (mm)	3.30 400 x 240
flexInduction Zone right – power (kW) / dimensions (mm)	3.30 400 x 240
Extended flexInduction rear left – power (kW) / dimensions (mm)	–
Extended flexInduction rear right – power (kW) / dimensions (mm)	–
CombiZone left – power (kW) / dimensions (mm)	–
CombiZone right – power (kW) / dimensions (mm)	–
Rear left zone – with powerBoost (max. kW)	3.70
Rear right zone – with powerBoost (max. kW)	3.70
Rear centre zone – with powerBoost (max. kW)	3.70
Front centre zone – with powerBoost (max. kW)	–
Front left zone – with powerBoost (max. kW)	3.70
Front right zone – with powerBoost (max. kW)	3.70

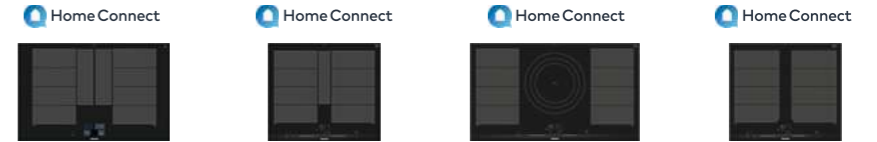

flexInduction hob specifications

APPLIANCE TYPE	FLEXINDUCTION HOB			
Design family	iQ700	iQ700	iQ700	iQ700
Model number	EX875KYV1E ¹	EX675LYV1E ¹	EX975LVV1E	EX675LXV1E
Availability	From June 2022	From June 2022		
DESIGN				
Width (mm)	812	602	912	602
Control position	Front	Front	Front	Front
Control type	TFT Control	Dual lightSlider	Dual lightSlider	Dual lightSlider
Style	Stainless steel side trim	Stainless steel side trim	Stainless steel side trim	Stainless steel side trim
KEY FEATURES				
Home Connect	■	■	■	■
cookConnect	■	■	■	■
Full Touch colour display with dish categories	■	–	–	–
cookingSensor Plus ready ¹	–	–	–	–
fryingSensor	5 settings	5 settings	4 settings	4 settings
Number of flexInduction zones	2	2	2	2
Extended flexInduction zone ²	2	1	–	–
Number of combiZones	–	–	–	–
powerBoost	■	■	■	■
panBoost	■	■	■	■
powerMove	3 stages	3 stages	3 stages	3 stages
FEATURES				
Number of individual zones	4	4	5	4
Power levels	17	17	17	17
Digital display	■	■	■	■
QuickStart	■	–	■	■
Restart function	■	■	■	■
quickStop	–	–	–	–
flexMotion automatic setting transfer	■	■	–	–
Wipe protection function	■	■	■	■
Keep warm function	■	■	■	■
Energy consumption display	■	■	■	■
Demo mode	■	■	■	■
SAFETY FEATURES				
Main on/off switch	■	■	■	■
Residual heat Indicator	■	■	■	■
Safety lock	■	■	■	■
Timer with automatic switch off for each zone	■	■	■	■
Count up timer / Automatic pan recognition	■ / ■	■ / ■	■ / ■	■ / ■
PERFORMANCE / TECHNICAL INFORMATION				
Nominal voltage (V)	220-240	220-240	220-240	220-240
Maximum power output (W) / Electrical cable length (cm)	7,400 / 110	7,400 / 110	11,100 / 110	7,400 / 110
GB plug	–	–	–	–
One continuous cooking zone – power (kW) / dimensions (mm)	–	–	–	–
One continuous cooking zone – with powerBoost (max. kW)	–	–	–	–
Rear left flexInduction zone – power (kW) / dimensions (mm)	2.20 200 x 230	2.20 200 x 230	2.20 200 x 240	2.20 200 x 240
Rear left zone – power (kW) / diameter (mm)	–	–	–	–
Rear right flexInduction zone – power (kW) / dimensions (mm)	2.20 200 x 230	2.20 200 x 230	2.20 200 x 240	2.20 200 x 240
Rear right zone – power (kW) / diameter (mm)	–	–	–	–
Rear centre zone – power (kW) / diameter (mm)	–	–	3.30 300 x 240	–
Front centre zone – power (kW) / diameter (mm)	–	–	–	–
Front left flexInduction zone – power (kW) / dimensions (mm)	2.20 200 x 230	2.20 200 x 230	2.20 200 x 240	2.20 200 x 240
Front left zone – power (kW) / diameter (mm)	–	–	–	–
Front right flexInduction zone – power (kW) / dimensions (mm)	2.20 200 x 230	2.20 200 x 230	2.20 200 x 240	2.20 200 x 240
Front right zone – power (kW) / diameter (mm)	–	–	–	–
flexInduction Zone left – power (kW) / dimensions (mm)	3.30 400 x 230	3.30 400 x 230	3.30 400 x 240	3.30 400 x 240
flexInduction Zone right – power (kW) / dimensions (mm)	3.30 400 x 230	3.30 400 x 230	3.30 400 x 240	3.30 400 x 240
Extended flexInduction rear left – power (kW) / dimensions (mm)	3.30 300 x 300	3.30 300 x 300	–	–
Extended flexInduction rear right – power (kW) / dimensions (mm)	3.30 300 x 300	3.30 300 x 300	–	–
CombiZone left – power (kW) / dimensions (mm)	–	–	–	–
CombiZone right – power (kW) / dimensions (mm)	–	–	–	–
Rear left zone – with powerBoost (max. kW)	3.70	3.70	3.70	3.70
Rear right zone – with powerBoost (max. kW)	3.70	3.70	3.70	3.70
Rear centre zone – with powerBoost (max. kW)	–	–	3.70	–
Front centre zone – with powerBoost (max. kW)	–	–	–	–
Front left zone – with powerBoost (max. kW)	3.70	3.70	3.70	3.70
Front right zone – with powerBoost (max. kW)	3.70	3.70	3.70	3.70

■ Yes, model has this feature. – Feature not available for this model.
All models comply with COMMISSION (EC) No. 1275/2008 with regard to ecodesign requirements for standby and off mode electric power consumption.
¹Max 3 sensors at any time. "Ready" identifies products with feature enabled, sensor available as additional purchase. If sensor is supplied, number supplied is detailed.
²On 60cm model, the single centre aux inductor can work only with either the left or right zones. On the 80cm models, there are two aux inductors, one allocated each to the left and right zones. No bridge is possible to use 2 aux zones together.
³Not compatible with Domino Hobs.
Data valid in this table as of June 2022. Subject to modification without prior notice.

Induction hobs

flexInduction hob specifications



APPLIANCE TYPE	FLEXINDUCTION HOB			
Design family	iQ700	iQ700	iQ700	iQ700
Model number	EX275FXB1E	EX879FVC1E	EX851FVC1E	EX651FEC1E
DESIGN				
Width (mm)	912	812	812	592
Control position	Front	Front	Front	Front
Control type	touchSlider	touchSlider	touchSlider	touchSlider
Style	Stainless steel side trim	Stainless steel side trim	Three sided bevel	Three sided bevel
KEY FEATURES				
Home Connect	-	-	-	-
cookConnect	-	-	-	-
Full Touch colour display with dish categories	-	-	-	-
cookingSensor Plus ready ¹	-	-	-	-
fryingSensor	-	4 settings	4 settings	5 settings
Number of flexInduction zones	2	1	1	1
Extended flexInduction zone ²	-	-	-	-
Number of combiZones	-	-	-	-
powerBoost	■	■	■	■
panBoost	-	-	-	-
powerMove	3 stages	3 stages	3 stages	3 stages
FEATURES				
Number of individual zones	4	5	5	4
Power levels	17	17	17	17
Digital display	■	■	■	■
QuickStart	■	■	■	■
Restart function	■	■	■	■
quickStop	-	-	-	-
flexMotion automatic setting transfer	■	-	-	-
Wipe protection function	■	■	■	■
Keep warm function	-	-	-	-
Energy consumption display	■	■	■	■
Demo mode	-	-	-	-
SAFETY FEATURES				
Main on/off switch	■	■	■	■
Residual heat Indicator	■	■	■	■
Safety lock	■	■	■	■
Timer with automatic switch off for each zone	■	■	■	■
Count up timer / Automatic pan recognition	■ / ■	■ / -	■ / -	■ / ■
PERFORMANCE / TECHNICAL INFORMATION				
Nominal voltage (V)	220-240	220-240	220-240	220-240
Maximum power output (W) / Electrical cable length (cm)	7,400 / 110	7,400 / 110	7,400 / 110	7,400 / 110
GB plug	-	-	-	-
One continuous cooking zone – power (kW) / dimensions (mm)	-	-	-	-
One continuous cooking zone – with powerBoost (max. kW)	-	-	-	-
Rear left flexInduction zone – power (kW) / dimensions (mm)	2.20	210 x 200	-	-
Rear left zone – power (kW) / diameter (mm)	-	-	1.40	145
Rear right flexInduction zone – power (kW) / dimensions (mm)	2.20	210 x 200	2.20	200 x 210
Rear right zone – power (kW) / diameter (mm)	-	-	-	-
Rear centre zone – power (kW) / diameter (mm)	-	-	2.20	240
Front centre zone – power (kW) / diameter (mm)	-	-	-	-
Front left flexInduction zone – power (kW) / dimensions (mm)	2.20	210 x 200	-	-
Front left zone – power (kW) / diameter (mm)	-	-	1.80	180
Front right flexInduction zone – power (kW) / dimensions (mm)	2.20	210 x 200	2.20	200 x 210
Front right zone – power (kW) / diameter (mm)	-	-	-	-
flexInduction Zone left – power (kW) / dimensions (mm)	3.30	210 x 400	-	-
flexInduction Zone right – power (kW) / dimensions (mm)	3.30	210 x 400	3.30	400 x 210
Extended flexInduction rear left – power (kW) / dimensions (mm)	-	-	-	-
Extended flexInduction rear right – power (kW) / dimensions (mm)	-	-	-	-
CombiZone left – power (kW) / dimensions (mm)	-	-	-	-
CombiZone right – power (kW) / dimensions (mm)	-	-	-	-
Rear left zone – with powerBoost (max. kW)	3.70	2.20	2.20	3.70
Rear right zone – with powerBoost (max. kW)	3.70	3.70	3.70	2.20
Rear centre zone – with powerBoost (max. kW)	-	3.70	3.70	-
Front centre zone – with powerBoost (max. kW)	-	-	-	-
Front left zone – with powerBoost (max. kW)	3.70	3.10	3.10	3.70
Front right zone – with powerBoost (max. kW)	3.70	3.70	3.70	3.70

■ Yes, model has this feature. – Feature not available for this model.
 All models comply with COMMISSION (EC) No. 1275/2008 with regard to ecodesign requirements for standby and off mode electric power consumption.
¹Max 3 sensors at any time. "Ready" identifies products with feature enabled, sensor available as additional purchase. If sensor is supplied, number supplied is detailed.
²On 60cm model, the single centre aux inductor can work only with either the left or right zones. On the 80cm models, there are two aux inductors, one allocated each to the left and right zones. No bridge is possible to use 2 aux zones together.
 Data valid in this table as of June 2022. Subject to modification without prior notice.

iQ500 ED851FWB5E

Induction hob Black glass

80cm

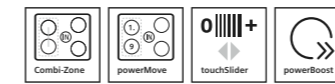
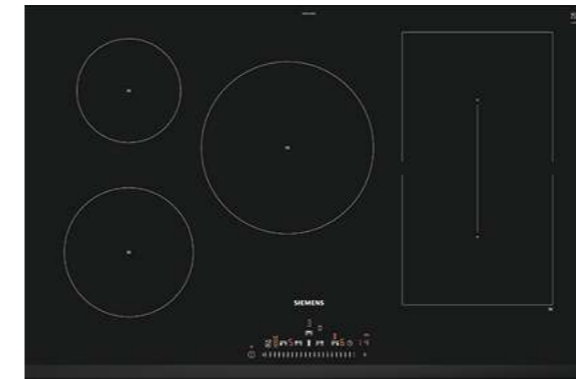

Induction hob specifications

APPLIANCE TYPE	INDUCTION HOB	
Design family	iQ500	
Model number	ED851FWB5E	
DESIGN		
Width (mm)	802	
Control position	Front	
Control type	touchSlider	
Style	Three sided bevel	
KEY FEATURES		
Home Connect	-	
cookConnect	-	
Full Touch colour display with dish categories	-	
cookingSensor Plus ready ¹	-	
fryingSensor	-	
Number of flexInduction zones	-	
Extended flexInduction Zone ²	-	
Number of combiZones	1	
powerBoost	■	
panBoost	-	
powerMove	2 stages	
FEATURES		
Number of individual zones	5	
Power levels	17	
Digital display	■	
QuickStart	■	
Restart function	■	
quickStop	-	
flexMotion automatic setting transfer	-	
Wipe protection function	■	
Keep warm function	-	
Energy consumption display	■	
Demo mode	-	
SAFETY FEATURES		
Main on/off switch	■	
Residual heat Indicator	■	
Safety lock	■	
Timer with automatic switch off for each zone	■	
Count up timer / Automatic pan recognition	- / ■	
PERFORMANCE / TECHNICAL INFORMATION		
Nominal voltage (V)	220-240	
Maximum power output (W) / Electrical cable length (cm)	7,400 / 110	
GB plug	-	
One continuous cooking zone – power (kW) / dimensions (mm)	-	
One continuous cooking zone – with powerBoost (max. kW)	-	
Rear left flexInduction zone – power (kW) / dimensions (mm)	1.40	145
Rear left zone – power (kW) / diameter (mm)	2.20	190 x 210
Rear right flexInduction zone – power (kW) / dimensions (mm)	-	-
Rear right zone – power (kW) / diameter (mm)	2.20	240
Rear centre zone – power (kW) / diameter (mm)	-	-
Front centre zone – power (kW) / diameter (mm)	-	-
Front left flexInduction zone – power (kW) / dimensions (mm)	1.80	180
Front left zone – power (kW) / diameter (mm)	2.20	190 x 210
Front right flexInduction zone – power (kW) / dimensions (mm)	-	-
Front right zone – power (kW) / diameter (mm)	-	-
flexInduction Zone left – power (kW) / dimensions (mm)	3.60	380 x 210
flexInduction Zone right – power (kW) / dimensions (mm)	-	-
Extended flexInduction rear left – power (kW) / dimensions (mm)	-	-
Extended flexInduction rear right – power (kW) / dimensions (mm)	-	-
CombiZone left – power (kW) / dimensions (mm)	-	-
CombiZone right – power (kW) / dimensions (mm)	-	-
Rear left zone – with powerBoost (max. kW)	2.20	-
Rear right zone – with powerBoost (max. kW)	3.70	-
Rear centre zone – with powerBoost (max. kW)	3.70	-
Front centre zone – with powerBoost (max. kW)	-	-
Front left zone – with powerBoost (max. kW)	3.10	-
Front right zone – with powerBoost (max. kW)	3.70	-

■ Yes, model has this feature. – Feature not available for this model.
 All models comply with COMMISSION (EC) No. 1275/2008 with regard to ecodesign requirements for standby and off mode electric power consumption.
¹Max 3 sensors at any time. "Ready" identifies products with feature enabled, sensor available as additional purchase. If sensor is supplied, number supplied is detailed.
²On 60cm model, the single centre aux inductor can work only with either the left or right zones. On the 80cm models, there are two aux inductors, one allocated each to the left and right zones. No bridge is possible to use 2 aux zones together.
 Data valid in this table as of June 2022. Subject to modification without prior notice.

Induction hob specifications



APPLIANCE TYPE	INDUCTION HOBS					
Design family	TQ500	TQ100	TQ100	TQ100	TQ100	
Model number	ED651FSB5E	EH801FVB1E	EH601FEB1E	EH845FVB1E	EH645FEB1E	
DESIGN						
Width (mm)	592	792	572	795	583	
Control position	Front	Front	Front	Front	Front	
Control type	touchSlider	touchSlider	touchSlider	touchSlider	touchSlider	
Style	Three sided bevel	Flush fit	Flush fit	Steel frame	Steel frame	
KEY FEATURES						
Home Connect	-	-	-	-	-	
cookConnect	-	-	-	-	-	
Full Touch colour display with dish categories	-	-	-	-	-	
cookingSensor Plus ready ¹	-	-	-	-	-	
fryingSensor	-	-	-	-	-	
Number of flexInduction zones	-	-	-	-	-	
Extended flexInduction Zone ²	-	-	-	-	-	
Number of combiZones	1	-	-	-	-	
powerBoost	■	■	■	■	■	
panBoost	-	-	-	-	-	
powerMove	2 stages	-	-	-	-	
FEATURES						
Number of individual zones	4	5	4	5	4	
Power levels	17	17	17	17	17	
Digital display	■	■	■	■	■	
QuickStart	■	■	■	■	■	
Restart function	■	■	■	■	■	
quickStop	■	-	-	-	-	
flexMotion automatic setting transfer	-	-	-	-	-	
Wipe protection function	■	■	■	■	■	
Keep warm function	-	-	-	-	-	
Energy consumption display	■	■	■	■	■	
Demo mode	-	-	-	-	-	
SAFETY FEATURES						
Main on/off switch	■	■	■	■	■	
Residual heat Indicator	■	■	■	■	■	
Safety lock	■	■	■	■	■	
Timer with automatic switch off for each zone	■	■	■	■	■	
Count up timer / Automatic pan recognition	- / ■	- / ■	- / ■	- / ■	- / ■	
PERFORMANCE / TECHNICAL INFORMATION						
Nominal voltage (V)	220-240	220-240	220-240	220-240	220-240	
Maximum power output (W) / Electrical cable length (cm)	6,900 / 110	7,400 / 110	7,400 / 110	7,400 / 110	7,400 / 110	
GB plug	-	-	-	-	-	
One continuous cooking zone – power (kW) / dimensions (mm)	-	-	-	-	-	
One continuous cooking zone – with powerBoost (max. kW)	-	-	-	-	-	
Rear left flexInduction zone – power (kW) / dimensions (mm)	2.20	190 x 210	-	-	-	
Rear left zone – power (kW) / diameter (mm)	-	-	1.40	145	1.80	180
Rear right flexInduction zone – power (kW) / dimensions (mm)	-	-	-	-	-	-
Rear right zone – power (kW) / diameter (mm)	1.40	145	1.40	145	1.40	145
Rear centre zone – power (kW) / diameter (mm)	-	-	2.20	240	-	-
Front centre zone – power (kW) / diameter (mm)	-	-	-	-	-	-
Front left flexInduction zone – power (kW) / dimensions (mm)	2.20	190 x 210	-	-	-	-
Front left zone – power (kW) / diameter (mm)	-	-	1.80	180	1.80	180
Front right flexInduction zone – power (kW) / dimensions (mm)	-	-	-	-	-	-
Front right zone – power (kW) / diameter (mm)	1.80	180	2.20	210	2.20	210
flexInduction Zone left – power (kW) / dimensions (mm)	3.60	380 x 210	-	-	-	-
flexInduction Zone right – power (kW) / dimensions (mm)	-	-	-	-	-	-
Extended flexInduction rear left – power (kW) / dimensions (mm)	-	-	-	-	-	-
Extended flexInduction rear right – power (kW) / dimensions (mm)	-	-	-	-	-	-
CombiZone left – power (kW) / dimensions (mm)	-	-	-	-	-	-
CombiZone right – power (kW) / dimensions (mm)	-	-	-	-	-	-
Rear left zone – with powerBoost (max. kW)	3.70	2.20	3.10	2.20	3.10	
Rear right zone – with powerBoost (max. kW)	2.20	2.20	2.20	2.20	2.20	
Rear centre zone – with powerBoost (max. kW)	-	3.70	-	3.70	-	
Front centre zone – with powerBoost (max. kW)	-	-	-	-	-	
Front left zone – with powerBoost (max. kW)	3.70	3.10	3.10	3.10	3.10	
Front right zone – with powerBoost (max. kW)	3.10	3.70	3.70	3.70	3.70	

■ Yes, model has this feature. – Feature not available for this model.
 All models comply with COMMISSION (EC) No. 1275/2008 with regard to ecodesign requirements for standby and off mode electric power consumption.
¹Max 3 sensors at any time. "Ready" identifies products with feature enabled, sensor available as additional purchase. If sensor is supplied, number supplied is detailed.
²On 60cm model, the single centre aux inductor can work only with either the left or right zones. On the 80cm models, there are two aux inductors, one allocated each to the left and right zones.
 No bridge is possible to use 2 aux zones together.
 Data valid in this table as of June 2022. Subject to modification without prior notice.

Induction hob specifications



APPLIANCE TYPE	INDUCTION HOBS			
Design family	TQ100	TQ100	TQ100	TQ100
Model number	EU631FEB1E	EU611BEB1E	EU631BEF1B	EU61RAGA5B
DESIGN				
Width (mm)	592	592	592	592
Control position	Front	Front	Front	Front
Control type	touchSlider	touchControl	touchControl	touchControl
Style	Front bevel	Frameless	Front bevel	Frameless
KEY FEATURES				
Home Connect	-	-	-	-
cookConnect	-	-	-	-
Full Touch colour display with dish categories	-	-	-	-
cookingSensor Plus ready ¹	-	-	-	-
fryingSensor	-	-	-	-
Number of flexInduction zones	-	-	-	-
Extended flexInduction Zone ²	-	-	-	-
Number of combiZones	-	-	-	-
powerBoost	■	■	■	■
panBoost	-	-	-	-
powerMove	-	-	-	-
FEATURES				
Number of individual zones	4	4	4	4
Power levels	17	17	17	9
Digital display	■	■	■	■
QuickStart	■	■	■	■
Restart function	■	■	■	■
quickStop	-	■	■	■
flexMotion automatic setting transfer	■	-	-	-
Wipe protection function	■	-	-	-
Keep warm function	-	-	-	-
Energy consumption display	■	-	-	-
Demo mode	-	-	-	-
SAFETY FEATURES				
Main on/off switch	■	■	■	■
Residual heat Indicator	■	■	■	■
Safety lock	■	■	■	■
Timer with automatic switch off for each zone	■	■	■	■
Count up timer / Automatic pan recognition	- / ■	- / ■	- / ■	- / ■
PERFORMANCE / TECHNICAL INFORMATION				
Nominal voltage (V)	220-240	220-240	220-240	220-240
Maximum power output (W) / Electrical cable length (cm)	4,600 / 110	4,600 / 110	3,700 / 110	3,700 / 110
GB plug	-	-	■	■
One continuous cooking zone – power (kW) / dimensions (mm)	-	-	-	-
One continuous cooking zone – with powerBoost (max. kW)	-	-	-	-
Rear left flexInduction zone – power (kW) / dimensions (mm)	-	-	-	-
Rear left zone – power (kW) / diameter (mm)	1.80	180	1.80	180
Rear right flexInduction zone – power (kW) / dimensions (mm)	-	-	-	-
Rear right zone – power (kW) / diameter (mm)	1.40	145	1.40	145
Rear centre zone – power (kW) / diameter (mm)	-	-	-	-
Front centre zone – power (kW) / diameter (mm)	-	-	-	-
Front left flexInduction zone – power (kW) / dimensions (mm)	-	-	-	-
Front left zone – power (kW) / diameter (mm)	1.80	180	1.80	180
Front right flexInduction zone – power (kW) / dimensions (mm)	-	-	-	-
Front right zone – power (kW) / diameter (mm)	2.20	210	2.20	210
flexInduction Zone left – power (kW) / dimensions (mm)	-	-	-	-
flexInduction Zone right – power (kW) / dimensions (mm)	-	-	-	-
Extended flexInduction rear left – power (kW) / dimensions (mm)	-	-	-	-
Extended flexInduction rear right – power (kW) / dimensions (mm)	-	-	-	-
CombiZone left – power (kW) / dimensions (mm)	-	-	-	-
CombiZone right – power (kW) / dimensions (mm)	-	-	-	-
Rear left zone – with powerBoost (max. kW)	3.10	3.10	3.00	3.10
Rear right zone – with powerBoost (max. kW)	2.20	2.20	2.20	-
Rear centre zone – with powerBoost (max. kW)	-	-	-	-
Front centre zone – with powerBoost (max. kW)	-	-	-	-
Front left zone – with powerBoost (max. kW)	3.10	3.10	3.00	-
Front right zone – with powerBoost (max. kW)	3.70	3.70	3.00	-

■ Yes, model has this feature. – Feature not available for this model.
 All models comply with COMMISSION (EC) No. 1275/2008 with regard to ecodesign requirements for standby and off mode electric power consumption.
¹Max 3 sensors at any time. "Ready" identifies products with feature enabled, sensor available as additional purchase. If sensor is supplied, number supplied is detailed.
²On 60cm model, the single centre aux inductor can work only with either the left or right zones. On the 80cm models, there are two aux inductors, one allocated each to the left and right zones.
 No bridge is possible to use 2 aux zones together.
 Data valid in this table as of June 2022. Subject to modification without prior notice.

quickLite ceramic hobs

iQ300 ET81RBHA1D

Ceramic hob
Black glass

80cm

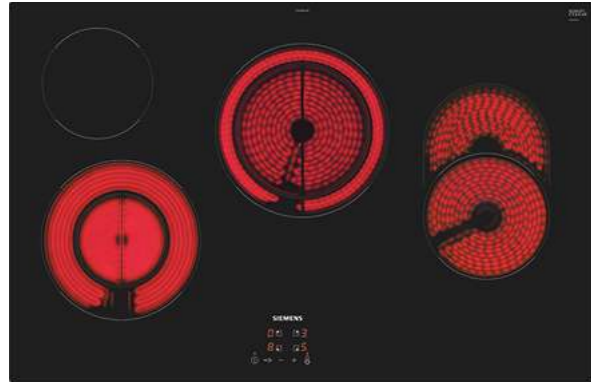

quickLite ceramic hob specifications



APPLIANCE TYPE		QUICKLITE CERAMIC HOB	
Design family		iQ300	
Model number		ET81RBHA1D	
DESIGN			
Width (mm)		802	
Control position		Front	
Control type		touchControl	
Style		Frameless	
FEATURES			
Number of individual zones		4	
Number of dual zones		1	
Number of extendable zones		2	
powerBoost		-	
Power levels		17	
Digital display		■	
Restart function		■	
Energy consumption display		-	
Main on/off switch		■	
SAFETY FEATURES			
Residual heat indicator		■	
Timer with automatic switch off for each zone		■	
Safety lock		■	
Safety time switch off		■	
Wipe protection function		-	
PERFORMANCE / TECHNICAL INFORMATION			
Nominal voltage (V)		220-240	
Maximum power output (W)		7,400	
Electrical cable length (cm)		-	
GB plug		-	
Rear left zone – power (kW) / diameter (mm)		1.2	145
Rear right zone – power (kW) / diameter (mm)		-	-
Rear centre zone – power (kW) / diameter (mm)		1.5 (2.4)	180 (230)
Front centre zone – power (kW) / diameter (mm)		-	-
Front left zone – power (kW) / diameter (mm)		0.75 (2.2)	120 (210)
Front right zone – power (kW) / diameter (mm)		1.8 (2.6)	170 (265)
Rear left zone – with powerBoost (max. kW)		-	-
Rear right zone – with powerBoost (max. kW)		-	-
Rear centre zone – with powerBoost (max. kW)		-	-
Front centre zone – with powerBoost (max. kW)		-	-
Front left zone – with powerBoost (max. kW)		-	-
Front right zone – with powerBoost (max. kW)		-	-

■ Yes, model has this feature. – Feature not available for this model.
All models comply with COMMISSION (EC) No. 1275/2008 with regard to ecodesign requirements for standby and off mode electric power consumption.
Data valid in this table as of June 2022. Subject to modification without prior notice.

quickLite ceramic hob specifications



APPLIANCE TYPE		iQ100		iQ100	
Design family		ET61RBEA1E		ET61RCEA1E	
Model number		ET61RBEA1E		ET61RCEA1E	
DESIGN					
Width (mm)		592		592	
Control position		Front		Right hand-side	
Control type		touchControl		Dials	
Style		Frameless		Frameless	
FEATURES					
Number of individual zones		4		4	
Number of dual zones		-		-	
Number of extendable zones		-		-	
powerBoost		-		-	
Power levels		17		9	
Digital display		■		-	
Restart function		■		-	
Energy consumption display		-		-	
Main on/off switch		■		-	
SAFETY FEATURES					
Residual heat indicator		■		■	
Timer with automatic switch off for each zone		-		-	
Safety lock		■		-	
Safety time switch off		■		-	
Wipe protection function		-		-	
PERFORMANCE / TECHNICAL INFORMATION					
Nominal voltage (V)		220-240		220-240	
Maximum power output (W)		6600		6600	
Electrical cable length (cm)		-		-	
GB plug		-		-	
Rear left zone – power (kW) / diameter (mm)		2	180	2.2	210
Rear right zone – power (kW) / diameter (mm)		1.2	145	1.2	145
Rear centre zone – power (kW) / diameter (mm)		-	-	-	-
Front centre zone – power (kW) / diameter (mm)		-	-	-	-
Front left zone – power (kW) / diameter (mm)		1.2	145	1.2	145
Front right zone – power (kW) / diameter (mm)		2.2	210	2	180
Rear left zone – with powerBoost (max. kW)		-	-	-	-
Rear right zone – with powerBoost (max. kW)		-	-	-	-
Rear centre zone – with powerBoost (max. kW)		-	-	-	-
Front centre zone – with powerBoost (max. kW)		-	-	-	-
Front left zone – with powerBoost (max. kW)		-	-	-	-
Front right zone – with powerBoost (max. kW)		-	-	-	-

■ Yes, model has this feature. – Feature not available for this model.
All models comply with COMMISSION (EC) No. 1275/2008 with regard to ecodesign requirements for standby and off mode electric power consumption.
Data valid in this table as of June 2022. Subject to modification without prior notice.

Gas hobs

iQ 700 ER9A6SB70

Gas hob
Black ceramic glass

90cm

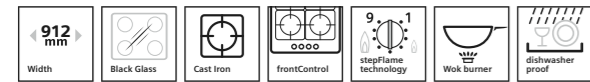
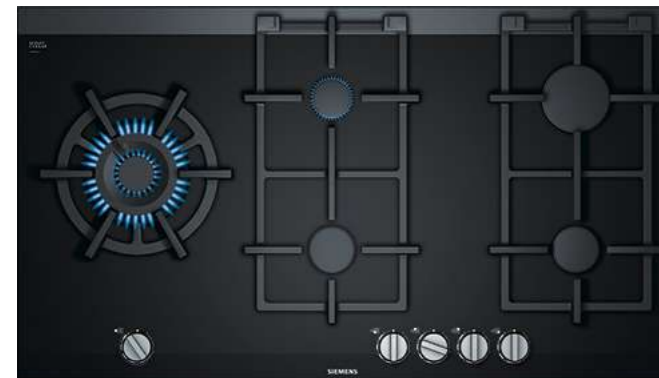

2
Year Warranty

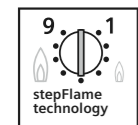

stepFlame technology
Introducing the ground-breaking innovation in gas hobs: stepFlame. Offering 9 precise power levels to give you the control of an electric hob, with gas.

Gas hob specifications



APPLIANCE TYPE	GAS HOB
Design family	iQ 700
Model number	ER9A6SB70
Availability	From June 2022
	Stainless steel / stainless steel trim
	Black / premium black
DESIGN	
Hob surface type	Ceramic glass
Width (mm)	912
Control position	Front
Comfort Profile	■
Can be combined with other models with Comfort Profile	■
Installation flush with work top possible	–
KEY FEATURES	
stepFlame Technology	■
Digital power level display	–
Number of dual circuit wok style burners ¹	1
High power (5.0kW+) wok burner ²	■
Dual control wok burner ³	■
FEATURES	
Number of cooking zones	5
Individual power levels	9
Variable power levels	–
Cast iron pan supports	3
Cast iron finish pan supports	–
Dishwasher safe pan supports ⁴	■
Low profile single piece burners	■
Two piece burners	–
SAFETY FEATURES	
Ignition via control dials	■
Flame failure safety device	■
PERFORMANCE / TECHNICAL INFORMATION	
Nominal voltage (V)	220-240
Maximum gas power output load (A)	13,700
Total connected electrical load (max. W)	2.0
Cable length (cm)	150
GB plug	–
Left burner power (kW)	6.00
Front left burner power (kW)	–
Back left burner power (kW)	–
Centre/Centre front burner power (kW)	1.90
Centre back burner power (kW)	1.10
Front right burner power (kW)	1.90
Back right burner power (kW)	2.80
Right burner power (kW)	–
Pre-set for natural gas	■
CE Marked	■
STANDARD ACCESSORIES	
Wok stand ⁵	■
LPG jets	28-30 / 37mbar
OPTIONAL ACCESSORIES	
Connecting Strip to link to other Comfort Profile models	HZ394301

■ Yes, model has this feature. – Feature not available for this model.
All models comply with COMMISSION (EC) No. 1275/2008 with regard to ecodesign requirements for standby and off mode electric power consumption.

¹Dual circuit means standard outer flame ring plus 2nd inner flame ring.
²High power output for rapid heating – especially valuable for flash and wok frying.
³Dual control means the inner and outer rings of a dual circuit burner can be controlled independently.
⁴Pan supports can be cleaned in the dishwasher. Supports have special additional coating and hand finishing of enamel.
⁵For round based pans.
Data valid in this table as of April 2022. Subject to modification without prior notice.

Gas hob specifications



APPLIANCE TYPE	GAS HOB		
Design family	iQ 500	iQ 500	iQ 500
Model number	EP9A6SB90	EP7A6QB90	EP6A6HB20
	Stainless steel / stainless steel trim	–	–
	Black / premium black	■	■
DESIGN			
Hob surface type	Tempered glass	Tempered glass	Tempered glass
Width (mm)	915	752	600
Control position	Front	Front	Front
Comfort Profile	–	–	–
Can be combined with other models with Comfort Profile	–	–	–
Installation flush with work top possible	■	■	■
KEY FEATURES			
stepFlame Technology	■	■	■
Digital power level display	–	–	–
Number of dual circuit wok style burners ¹	1	1	1
High power (5.0kW+) wok burner ²	–	–	–
Dual control wok burner ³	■	■	–
FEATURES			
Number of cooking zones	5	5	4
Individual power levels	9	9	9
Variable power levels	–	–	–
Cast iron pan supports	5	5	4
Cast iron finish pan supports	–	–	–
Dishwasher safe pan supports ⁴	–	–	–
Low profile single piece burners	–	–	–
Two piece burners	■	■	■
SAFETY FEATURES			
Ignition via control dials	■	■	■
Flame failure safety device	■	■	■
PERFORMANCE / TECHNICAL INFORMATION			
Nominal voltage (V)	220-240	220-240	220-240
Maximum gas power output load (A)	11,500	11,500	8,000
Total connected electrical load (max. W)	1.1	1.1	1.1
Cable length (cm)	150	100	100
GB plug	–	–	–
Left burner power (kW)	4.00	–	–
Front left burner power (kW)	–	1.00	1.75
Back left burner power (kW)	–	1.75	1.75
Centre/Centre front burner power (kW)	1.00	4.00	–
Centre back burner power (kW)	1.75	–	–
Front right burner power (kW)	1.75	1.75	1.00
Back right burner power (kW)	3.00	3.00	3.50
Right burner power (kW)	–	–	–
Pre-set for natural gas	■	■	■
CE Marked	■	■	■
STANDARD ACCESSORIES			
Wok stand ⁵	–	–	–
LPG jets	28-30 / 37mbar	28-30 / 37mbar	28-30 / 37mbar
OPTIONAL ACCESSORIES			
Connecting Strip to link to other Comfort Profile models	–	–	–

■ Yes, model has this feature. – Feature not available for this model.
All models comply with COMMISSION (EC) No. 1275/2008 with regard to ecodesign requirements for standby and off mode electric power consumption.

¹Dual circuit means standard outer flame ring plus 2nd inner flame ring.
²High power output for rapid heating – especially valuable for flash and wok frying.
³Dual control means the inner and outer rings of a dual circuit burner can be controlled independently.
⁴Pan supports can be cleaned in the dishwasher. Supports have special additional coating and hand finishing of enamel.
⁵For round based pans.
Data valid in this table as of April 2022. Subject to modification without prior notice.

Gas hob specifications



APPLIANCE TYPE	GAS HOBS		
Design family	■ IQ500	■ IQ500	■ IQ500
Model number	EC9A5S890	EC7A5R890	EC6A5HC90
Stainless steel / stainless steel trim	■	■	■
Black / premium black	-	-	-
DESIGN			
Hob surface type	Metal	Metal	Metal
Width (mm)	915	750	582
Control position	Front	Front	Front
Comfort Profile	-	-	-
Can be combined with other models with Comfort Profile	-	-	-
Installation flush with work top possible	-	-	-
KEY FEATURES			
stepFlame Technology	■	■	■
Digital power level display	-	-	-
Number of dual circuit wok style burners ¹	1	1	1
High power (5.0kW+) wok burner ²	■	■	-
Dual control wok burner ³	■	■	■
FEATURES			
Number of cooking zones	5	5	4
Individual power levels	9	9	9
Variable power levels	-	-	-
Cast iron pan supports	3	3	2
Cast iron finish pan supports	-	-	-
Dishwasher safe pan supports ⁴	-	-	-
Low profile single piece burners	-	-	-
Two piece burners	■	■	■
SAFETY FEATURES			
Ignition via control dials	■	■	■
Flame failure safety device	■	■	■
PERFORMANCE / TECHNICAL INFORMATION			
Nominal voltage (V)	220-240	220-240	220-240
Maximum gas power output load (A)	12,500	12,500	8,000
Total connected electrical load (max. W)	1.1	1.1	1.1
Cable length (cm)	150	100	100
GB plug	-	-	-
Left burner power (kW)	5.00	-	-
Front left burner power (kW)	-	1.00	1.75
Back left burner power (kW)	-	1.75	1.75
Centre/Centre front burner power (kW)	1.00	5.00	-
Centre back burner power (kW)	1.75	-	-
Front right burner power (kW)	1.75	1.75	1.00
Back right burner power (kW)	3.00	3.00	3.50
Right burner power (kW)	-	-	-
Pre-set for natural gas	■	■	■
CE Marked	■	■	■
STANDARD ACCESSORIES			
Wok stand ⁵	-	-	-
LPG jets	28-30 / 37mbar	28-30 / 37mbar	28-30 / 37mbar
OPTIONAL ACCESSORIES			
Connecting Strip to link to other Comfort Profile models	-	-	-

■ Yes, model has this feature. – Feature not available for this model.
All models comply with COMMISSION (EC) No. 1275/2008 with regard to ecodesign requirements for standby and off mode electric power consumption.

¹Dual circuit means standard outer flame ring plus 2nd inner flame ring.
²High power output for rapid heating – especially valuable for flash and wok frying.
³Dual control means the inner and outer rings of a dual circuit burner can be controlled independently.
⁴Pan supports can be cleaned in the dishwasher. Supports have special additional coating and hand finishing of enamel.
⁵For round based pans.

Data valid in this table as of June 2022. Subject to modification without prior notice.

Gas hob specifications



APPLIANCE TYPE	GAS HOBS		
Design family	■ IQ500	■ IQ300	■ IQ100
Model number	EC6A5PB90	EG7B5QB90	EB6B5PB60
Stainless steel / stainless steel trim	■	■	■
Black / premium black	-	-	-
DESIGN			
Hob surface type	Metal	Metal	Metal
Width (mm)	582	750	580
Control position	Front	Front	Right side
Comfort Profile	-	-	-
Can be combined with other models with Comfort Profile	-	-	-
Installation flush with work top possible	-	-	-
KEY FEATURES			
stepFlame Technology	■	-	-
Digital power level display	-	-	-
Number of dual circuit wok style burners ¹	-	1	-
High power (5.0kW+) wok burner ²	-	-	-
Dual control wok burner ³	-	-	-
FEATURES			
Number of cooking zones	4	5	4
Individual power levels	9	9	-
Variable power levels	-	-	■
Cast iron pan supports	2	3	-
Cast iron finish pan supports	-	-	2
Dishwasher safe pan supports ⁴	-	-	-
Low profile single piece burners	-	-	-
Two piece burners	■	■	■
SAFETY FEATURES			
Ignition via control dials	■	■	■
Flame failure safety device	■	■	■
PERFORMANCE / TECHNICAL INFORMATION			
Nominal voltage (V)	220-240	220-240	220-240
Maximum gas power output load (A)	7,500	10,800	7,400
Total connected electrical load (max. W)	1.0	1.0	0.8
Cable length (cm)	100	150	100
GB plug	-	-	-
Left burner power (kW)	-	-	-
Front left burner power (kW)	1.75	1.00	3.00
Back left burner power (kW)	1.75	1.75	1.70
Centre/Centre front burner power (kW)	-	3.3	-
Centre back burner power (kW)	-	-	-
Front right burner power (kW)	1.00	1.75	1.00
Back right burner power (kW)	3.00	3.00	1.70
Right burner power (kW)	-	-	-
Pre-set for natural gas	■	■	■
CE Marked	■	■	■
STANDARD ACCESSORIES			
Wok stand ⁵	-	-	-
LPG jets	28-30 / 37mbar	28-30 / 37mbar	28-30 / 37mbar
OPTIONAL ACCESSORIES			
Connecting Strip to link to other Comfort Profile models	-	-	-

■ Yes, model has this feature. – Feature not available for this model.
All models comply with COMMISSION (EC) No. 1275/2008 with regard to ecodesign requirements for standby and off mode electric power consumption.

¹Dual circuit means standard outer flame ring plus 2nd inner flame ring.
²High power output for rapid heating – especially valuable for flash and wok frying.
³Dual control means the inner and outer rings of a dual circuit burner can be controlled independently.
⁴Pan supports can be cleaned in the dishwasher. Supports have special additional coating and hand finishing of enamel.
⁵For round based pans.

Data valid in this table as of June 2022. Subject to modification without prior notice.

Domino hobs

iQ 500 ET475FYB1E

Teppan Yaki domino hob
Steel/black glass

40cm



2
Year Warranty

Flexible cooking to your exact tastes:

Flexible cooking to your exact tastes: Create your own bespoke cooking area with a modular domino hob mix. If one hob is not enough or if you prefer a mix of fuel types, take a look through our selection of domino cooktops. The Siemens range offers specialist models such as a Teppan Yaki or single wok burner, which are perfect as an add-on to your current hob. The sleek black designs with steel dials or touchSlider controls perfectly bring the range together, meaning a combination can be installed to create your ideal cooking station.



Domino hob specifications

APPLIANCE TYPE	TEPPAN YAKI DOMINO HOB	FLEXINDUCTION DOMINO HOB
Design family	iQ 500	iQ 700
Model number	ET475FYB1E	EX375FXB1E
DESIGN		
Stainless steel / Stainless steel trim	-	-
Domino Hob Type	Teppan Yaki	Flex Induction
Black/Premium black	-	■
Hob surface type	Stainless Steel	Ceramic Glass
Width (mm)	392	302
Control position	Front	Front
Controls	touchSlider	touchSlider
KEY FEATURES		
powerMove Plus	-	■
Quick start function	-	■
restart function	-	■
Time for individual zones	-	■
power boost setting	-	■
stepFlame Technology	-	-
Digital power level display	■	■
Number of dual circuit wok style burners	-	-
High power (5.0kW+) wok burner	-	-
Dual control wok burner	-	-
"Diamond" shape burner layout	-	-
Dishwasher safe pan supports	-	-
Safety time switch off	■	■
Childproof Lock	■	■
FEATURES		
Number of cooking zones	1	2
Individual power levels	17	17
Variable power levels	■	-
Ignition via control dials	-	-
Flame failure safety device	-	-
Cast iron pan supports (number)	-	-
Cast iron finish pan supports (number)	-	-
Enamelled steel pan supports (number)	-	-
Low profile single piece burners	-	-
Two piece burners	-	-
Comfort Profile	-	-
Can be combined with other models with Comfort Profile	-	-
Installation flush with work top possible	-	-
PERFORMANCE / TECHNICAL INFORMATION		
Nominal voltage (V)	220-240	220-240
Maximum gas power output load (W)	-	-
Total connected electrical load (max. W)	1900.0	3700.0
Minimum Fuse Protection (A)	13A	-
Cable length (cm)	100	110
GB plug	-	-
Temperature range (°C)	160-240	-
Centre/Centre front burner power (kW)	-	-
Centre back burner power (kW)	-	-
Power induction front centre	-	2.2kW
Power induction rear centre	-	2.2kW
Max power centre flexInduction zone	-	3.7kW
Pre-set for natural gas	-	-
CE Marked	■	■
STANDARD ACCESSORY		
Wok stand	-	-
LPG jets	-	-
OPTIONAL ACCESSORY		
Connecting Strip to link to other Comfort Profile models	-	-

■ Yes, model has this feature. – Feature not available for this model.
All models comply with COMMISSION (EC) No. 1275/2008 with regard to ecodesign requirements for standby and off mode electric power consumption.

Data valid in this table as of June 2022. Subject to modification without prior notice.



Domino hob specifications

APPLIANCE TYPE	WOK DOMINO GAS HOB	DOMINO GAS HOB
Design family	iQ 700	iQ 700
Model number	ER3A6AB70	ER3A6BB70
Availability	From June 2022	From June 2022
DESIGN		
Stainless steel / Stainless steel trim	■	■
Domino Hob Type	Gas Hob	Gas Hob
Hob surface type	Ceramic glass	Ceramic glass
Width (mm)	302	302
Control position	Front	Front
Controls	Dials	Dials
KEY FEATURES		
stepFlame Technology	■	■
Digital power level display	-	-
Number of dual circuit wok style burners ¹	1	-
High power (5.0kW+) wok burner ²	■	-
Dual control wok burner ³	■	-
"Diamond" shape burner layout ⁴	-	-
Dishwasher safe pan supports ⁵	■	■
FEATURES		
Number of cooking zones	1	2
Individual power levels	9	9
Variable power levels	-	-
Ignition via control dials	■	■
Flame failure safety device	■	■
Cast iron pan supports (number)	1 x dishwasher safe	1 x dishwasher safe
Cast iron finish pan supports (number)	-	-
Enamelled steel pan supports (number)	-	-
Low profile single piece burners	■	■
Two piece burners	-	-
Comfort Profile	■	■
Can be combined with other models with Comfort Profile	■	■
Installation flush with work top possible	-	-
PERFORMANCE / TECHNICAL INFORMATION		
Nominal voltage (V)	220-240	220-240
Maximum gas power output load (W)	6,000	4,700
Total connected electrical load (max. W)	2.0	2.0
Minimum Fuse Protection (A)	3A	3A
Cable length (cm)	100	100
GB plug	-	-
Temperature Range (°C)	-	-
Centre/Centre front burner power (kW)	6.00	1.90
Centre back burner power (kW)	-	2.80
Power induction front centre	-	-
Power induction rear centre	-	-
Max power centre flexInduction zone	-	-
Pre-set for natural gas	■	■
CE Marked	■	■
STANDARD ACCESSORIES		
Wok stand ⁶	■	-
LPG jets	28-30 / 37mbar	28-30 / 37mbar
OPTIONAL ACCESSORIES		
Connecting strip to link to other Comfort Profile models	HEZ394301	HEZ394301

■ Yes, model has this feature. – Feature not available for this model.
All models comply with COMMISSION (EC) No. 1275/2008 with regard to ecodesign requirements for standby and off mode electric power consumption.

¹Dual circuit means standard outer flame ring plus 2nd inner flame ring.
²High power output for rapid heating – especially valuable for flash and wok frying.

³Dual control means the inner and outer rings of a dual circuit burner can be controlled independently.
⁴Diamond refers to the visual layout of the burners – i.e. Diamond shape as opposed to normal square layout for 60cm hobs.

Diamond layout offers:
– greater convenience / accessibility with 2 large pans at the same time.
– compared to models with wok on the rear zones, you can work with larger diameter wok pans without touching the rear wall and forcing the pan off centre over the burner.

– no need to reach over front zones to access the higher power burners.
– compared with a model with a wok at the front left there is a safety argument as it offers a good compromise between easy access and child safety.

– compared to wok front level, the extra distance to control dials allows a higher power wok burner to be used without making the controls too hot and offering added convenience in terms of power available.

⁵Pan supports can be cleaned in the dishwasher. Supports have special additional coating and hand finishing of enamel.
⁶For round based pans.
Data valid in this table as of June 2022. Subject to modification without prior notice.



Models shown above:
ER3A6AB70 wok domino hob,
ET475FYB1E Teppan Yaki domino hob
and EX375FXB1E flexInduction domino hob

Domino Hob Accessories

For additional cooking flexibility Siemens provide a range of accessories for our domino hobs.



CookingSensor Plus Wireless temperature sensor
HZ39050



Cast iron non-stick frying pan
HZ9FE280



Six piece pan set
HZ9SE060

OPTIONAL ACCESSORIES FOR DOMINO HOB	
CookingSensor Plus Wireless temperature sensor for cookingSensor Plus ready models	HZ39050
Connecting strip for use with side trim hobs	HZ394301
Four piece pan set, suited for induction, radiant ceramic and gas. Consists of 1 x sauté pan, 2 x pots with lids and 1 x milk pan	HZ9SE040
Six piece pan set, suited for induction, radiant ceramic and gas. Consists of 2 x sauté pan, 3 x pots with lids and 1 x milk pan	HZ9SE060
Cast iron non-stick frying pan, suited for induction, base diameter 185mm	HZ9FE280
BergHOFF three piece induction pan set	HZ9SE030
BergHOFF single induction coated frying pan 26cm	HZ9CF260
BergHOFF single induction pot 20cm	HZ9LP200
BergHOFF single induction pot 16cm	HZ9LP160
Griddle plate, approx. 40x20 cm for use with flexInduction	HZ390522
Teppan Yaki, approx. 40x20 cm for use with flexInduction	HZ390512
Oval roasting dish with lid for use with induction hobs	HZ390011
Steamer insert for use with HZ390011 roasting dish	HZ390012

For more details on the range of accessories available please ask your retailer or visit siemens-home.bsh-group.com/uk/store

Hoods. Outstanding performance, intelligently designed

The kitchen is the heart of the home. Not only is it a place to cook, it is a place to entertain, relax after a hard day's work, or spend time with friends and family.

Whether you choose a sleek ceiling hood, state-of-the-art glassdraftAir hood, a stylish chimney hood or integrated style hood our solutions will provide innovative design and a stylish finish to your kitchen. Selected Siemens hoods come with a quiet and energy efficient motor so you can cook in a more comfortable surrounding.

Siemens hoods work hard to keep your kitchen space fresh, and full of cleaner air whilst also providing ambient lighting. There is a hood for all kitchen designs, including the inductionAir Plus which combines an advanced induction hob with a high-performance extractor for even clearer views in your kitchen. See the hobs section for details on the inductionAir Plus (pages 63, 68 and 69).



Model shown: LD98WMM60B
glassdraftAir hood

HOODS

Siemens hood warranties:

2
Year Warranty

2 Year Warranty
A Two Year Warranty is available on all Siemens hoods listed in this brochure to protect against manufacturing and material faults during this warranty period.

To find out more about your warranty and for registration, please refer to page 175.

Installation solutions for every kitchen

Worktop installation.
glassdraftAir ventilation.



The perfect solution for keeping your kitchen design clear and with unhindered sightlines, the glassdraftAir stylish premium glass panel retracts fully into the unit when not in use. When in operation, its unique transparent design adds a subtle highlight to your kitchen, while its innovative Guided Air technology guarantees excellent performance from all cooking zones.

LD98WMM60B glassdraftAir ventilation

Ceiling installation.
Island and ceiling hoods.



LF91BUV50B island hood

Ideal if your hob is in the centre of your room. Our ceiling hoods can either be bold design statements installed over island units, or blend as unobtrusively into the ceiling itself as standard kitchen lighting.



LR97CAQ50B ceiling hood - flat motor design

Wall installation.

Decorative hoods, glass, box and pyramid chimney hoods.



LC91KWW60B angled hood



LC97AFM50B curved glass chimney hood



LC94PBC50B pyramid hood

Our stylish wall-mounted ventilation can be as beautiful and design led as they are effective. Our stunning angled hoods feature emotionLight Pro lighting that allows you to choose from 256 colours using the Home Connect app so you can create ambience in your living space. Our more traditional pyramid chimney and curved glass chimney hoods provide a classic but contemporary ventilation solution.



LC97BHM50B box chimney hood

Integrated furniture installation.
Canopy, telescopic and integrated hoods.



LB78574GB canopy hood



LI97SA561B telescopic hood



LE63MAC00B integrated hood

If you need to blend the hood into existing wall-mounted kitchen units, choose from a number of options perfect for mounting inside a cupboard space. These concealed hoods are ideal for a sleek modern kitchen.



Model shown: LF91BUV50B island hood

The power to perform.

A chosen hood must be powerful enough to effectively remove moisture and cooking odours from a kitchen. We recommend the hood should be able to change the air in the kitchen 6-12 times per hour. Using this quick calculation, you can check whether a hood is sufficiently powerful. Firstly, calculate the volume of the kitchen (HxWxD metres). Next multiply that figure by 12. The resulting figure is the ideal extraction rate required in intensive mode. Match this to a lower power level on the hood to avoid having to run at full power for increased efficiency.

FOR EXAMPLE

Room: 4m x 4m x 2.5m = 40m³

12 changes per hour in intensive operation: 12 x 40m³ = 480m³/h

So the hood must achieve >480m³/h in intensive mode.



Recirculation filters.

	STANDARD ODOUR FILTER	CLEANAIR FILTER*	CLEANAIR PLUS FILTER*	LONG LIFE REGENERATIVE FILTER*
standard high performance or regenerative				
Lifetime	6-12 months	6-12 months	12 months	10 years
Benefits	Simple installation, Anti-fish treatment	Increased surface area, Up to 3dB (A) sound reduction, improved extraction and performance, Anti-fish treatment	Anti-pollen functionality: the filter retains 99% of airborne pollen and deactivates allergens which are retained by the filter. Increased surface area, Up to 3dB (A) sound reduction, improved extraction and performance, Anti-fish treatment	High odour reduction, Up to 3dB (A) sound reduction, Regenerated in the oven every 4 months recommended (2 hours, 200°C), Improved extraction performance

*CleanAir and Regenerative filters not available for all styles of hood. Additional module may be required to house the filter. Images for example only, different filters may come in a different size and style.

Hood installation options

Ducted or recirculated?

For optimum performance, your extractor hood should be ducted to the outside of the house, so that the extracted air is vented outside. But sometimes this is not practical, so most Siemens hoods can also operate in recirculating mode; where the air is passed through the metal filter to remove grease, and then through a carbon filter to remove odours before being directed back into the kitchen.

Although the extraction rate is slightly lower when using this method than ducted extraction and the carbon odour filter will need to be replaced, recirculating the air offers an energy efficient benefit; cool air is retained in the home in the summer and warm air does not vent out during winter months.

- Ducted Ventilation**
- Extracts steam and odours
 - Effectively planned ducting system required

- Recirculated Ventilation**
- Removes over 90% of odours with cleanAir filters
 - Easy to install – no ducting required
 - Separate recirculation kit required

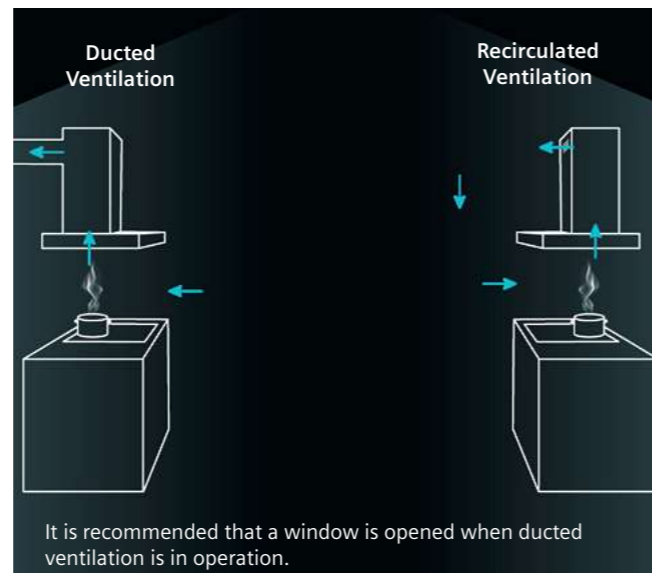

State-of-the-art efficiency with our iQ700 hoods with iQ drive.

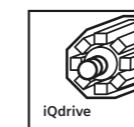

Siemens iQ700 hoods feature innovative technology that saves energy. This is thanks to the highly efficient, durable brushless iQdrive motor which is powerful, but requires very little energy to run. Capable of handling odours and grease in the most challenging cooking situations, and specially designed to last longer. The brushless iQdrive motor at the heart of our selected iQ700 hoods is capable of extracting a measured value of up to 991m³/h in our most powerful hood*.

*LC91KWW60B



Completely automatic ventilation

Control two appliances with one: cookConnect.

Explore more seamless cooking experiences by using the cookConnect system to connect your hob and hood, so they work together effortlessly.



cookConnect system

Hobs featuring Siemens cookConnect technology can now talk to cookConnect hoods via Wi-Fi. Either connect the two appliances directly, or through the Home Connect App. Once connected just switch on the hob and the hood will start automatically. Smart sensors in the hood detect steam and odours to adjust and optimise the extraction rate to keep your kitchen fresh and the steam under control. In addition to automatic extraction the lights will also illuminate your cooking space as soon as you turn the hob on. When you are finished, you no longer need to worry about turning the hood off as the the hood will turn itself off automatically once the climateControl sensor detects no further changes in the air quality.

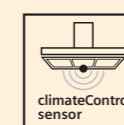

climateControl sensor

The climateControl sensor automatically adjusts the power level of the hood depending on the level of steam and odours keeping the kitchen fresher without having to manually adjust the power yourself. The climateControl Sensor is activated by selecting the "auto" button.



Model shown: LC91KWW60B angled wall hood

Hood key features



Download and install Home Connect App
Partners brought to you by Home Connect
HomeConnect | amazon alexa | Google Assistant

Hoods with Home Connect make cooking a breeze.

Home Connect

For Wi-Fi enabled hoods with Home Connect, explore more versatile ways of cooking. Control the lighting, select a power level, or even the fan run-on option, directly using your smartphone or tablet.

Take connected cooking a step further by using our voice control partner, Amazon Alexa, to also control these settings. Ask Alexa how to clean the filter, set ambient lights and start extraction, to name a few. All of these features also work with Google Assistant, making it even easier to connect with your hood.

Through the app you can even activate the automatic mode climateControl sensor, where the hood extractor will adjust its extraction rate depending on the amount of steam and odours so you have less to worry about when cooking.

With the cookConnect system you can even utilise the Home Connect App to connect your hood and hob together. This feature allows you to change your hood settings from the hob, so you have complete control from just one appliance.

Lighting to match your mood. Your extractor hood, your style, your light.

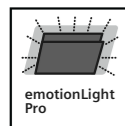

emotionLight Pro

Your extractor hood now adapts to your taste. Simply choose between many different background light colours – for an extractor hood that matches your preferences. The colour range is extendable via the Home Connect App, choose from 256 colours.

Using our partner, IFTTT, you can now set up Applets to change the colour of your hood depending on a variety of factors. For example if you purchased a Siemens oven with Home Connect, you could programme the hood colour to change to red when the oven finishes cooking. Simple ways to create new possibilities in your household.



Models shown below: LC91KWW60B
black glass angled chimney hood showing emotionLight colour examples



Other lighting options.

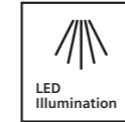
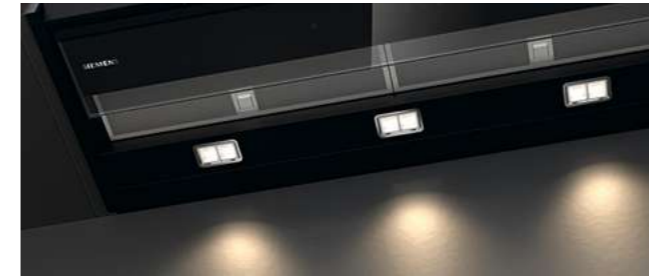

LED Illumination

All Siemens hoods are equipped with state-of-the-art LED lighting, ensuring the hob is illuminated evenly and clearly.



softLight with Dimmer

Allows you to dim the lights of the hood, perfect for when you are finished cooking and want to create a subtle glow in your kitchen.

Controlling your hood.

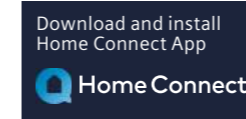

Home Connect and voice control

Activate and control your Wi-Fi enabled hood by using the Home Connect app or by speaking to Alexa or Google to take your connected cooking experience to the next level.



touchControl

The design of touchControl is integrated into the black glass panel for easy control at the touch of a finger, not to mention sleek design and easy cleaning.

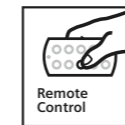

Remote control

With a hood installed in the ceiling it is important to have complete control. Siemens ceiling hoods come with a remote control to change and manage each setting with ease.



cookConnect system

Hobs featuring cookConnect technology talk to cookConnect hoods via Wi-Fi and automatically adjust by themselves.

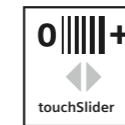

touchSlider

Control your Siemens hood with ease by simply sliding your finger along the touchSlider to select the power level. Stunning design meets sleek control with touchSlider.



pushControl

Simply select the setting by pushing the button.



Other product features.



Width

Indicates the width of the hood. Siemens offer a wide range of hoods to fit different sized niches within our range of hobs. For optimal results, the cooker hood should be at least as wide as the hob. Our hood widths range from 370-900mm.



Energy efficient hoods*

Siemens hoods feature innovations that make them incredibly energy efficient to run, from our durable and quiet brushless iQdrive motor to LED lighting.

*For individual product energy efficiency ratings please check individual product specifications.

Intensive setting

The intensive setting creates a powerful boost of extraction, perfect for tackling demanding food such as stir fry or steamed vegetables. This ensures moisture is properly eradicated, without misting windows and keeping the kitchen air fresher.

Boost Position

For our Angled and Flat hoods, the Boost Position is enabled by slightly pulling the front panel out to capture more steam and draw more air through the hood, which is particularly effective when frying meat or fish.

Interval Operation

With interval ventilation, the hood switches on automatically at the lowest level for 10 minutes every hour, to keep the air in the kitchen refreshed. The interval ventilation switches off after 24 hours.

Automatic after running time

This convenient feature reduces cooking odours by allowing the extractor to carry on running automatically after cooking has finished at a low speed for 3-30 minutes - the duration the extractor carries on for depends on the model.

Filter indication indicator system

The filter saturation indicators let you know when your hood's grease filters need to be cleaned with an illuminated symbol on the hood. For hoods installed with a recirculation filter, the saturation indicator will also notify you when the recirculation filter should be replaced or regenerated (depending on type of filter installed).

Worktop ventilation



Model shown: LD98WMM60B glassdraftAir hood

iQ700 LD98WMM60B

glassdraftAir Hood
Black with clear glass



glassdraftAir Hoods specifications

APPLIANCE TYPE	GLASSDRAFTAIR HOODS
Design family	iQ700
Model number	LD98WMM60B
Colour	Black glass
KEY FEATURES	
emotionLight Pro	–
Home Connect	–
cookConnect hob based hood control	■
climateControl sensor	■
Adjustable LED white colour temperature	–
iQdrive®	■
Intensive setting / Automatic intensive revert ¹	■
Grease / charcoal filter saturation indicators	■
FEATURES	
Suitable for ducted / recirculating operation	■ / ■
Type of control	Touch control
Power levels	3 + 2 intensive
Electronic power level display	–
Interval operation	–
Automatic after running (minutes)	10
Lighting	LED
softLight with dimmer function	–
Number of metal grease filter cassettes	2
PERFORMANCE / TECHNICAL INFORMATION	
Appliance width (mm)	912
Extraction Rate in m³/h ^{2,3}	
- ducted / recirculating at power level 1	229 / 172
- ducted / recirculating at power level 2	389 / 367
- ducted / recirculating at power level 3	519 / 472
- ducted / recirculating at power level 4 or intensive setting 1	630 / 482
- ducted / recirculating, intensive setting or intensive setting 2	833 / 596
Noise level (sound power) based on dB [A] re 1pW ^{2,4}	
- ducted / recirculating at power level 1	41 / 43
- ducted / recirculating at power level 2	56 / 59
- ducted / recirculating at power level 3	62 / 65
- ducted / recirculating at power level 4 or intensive setting 1	– / –
- ducted / recirculating, intensive setting or intensive setting 2	71 / 71
Pipe outlet diameter (mm)	150
Minimum distance above an electric / gas hob ⁵ (mm)	–
GB plug	■
Energy rating	A
OPTIONAL ACCESSORIES ⁶	
Long Life (10 year Regenerative) Recirculation Kit 90cm	LZ21WWJ12
CleanAir Plus Anti-Pollen Recirculation Kit 90cm	LZ21WWI17
Seamless Installation Kit 90cm	LZ29WWY12 M
Remote Motor Installation Kit	LZ21WWM11

■ Yes, model has this feature. – Feature not available for this model.
¹Power automatically reverts back to normal setting after intensive.
²Air Flow and noise declarations made in line with CECEC Code of Conduct.
³Measured according to EN61591 on largest pipe diameter.
⁴Sound power measured according to EN60704-3 on largest pipe diameter.
⁵From top of pan supports.
⁶A type of recirculating kit is required if recirculating. Depending on the model, a 'Recirculating odour filter kit' will consist of the following items: Charcoal filter, flexible hose, air duct, fixing components, installation instructions.
Data valid in this table as of June 2022. Subject to modification without prior notice.

The finishing touch for your kitchen. Now with flexible installation.

Extract cooking smells at source with the iQ700 glassdraftAir hood, ideal for keeping the sightlines of open plan kitchens. Conveniently placed within the worktop, this elegant hood can be automatically raised when needed, then disappears at the touch of a button. There is no need to worry about losing all your storage space beneath as you can place the motor somewhere more convenient with the remote installation kit.

The Siemens Remote Motor Installation Mounting Kit (LZ21WWM11) frees up space under the worktop and provides the option to mount the motor up to 3 metres away from the appliance. Image for illustrative purposes only. Ducting not supplied.



Model shown: LD98WMM60B glassdraftAir hood

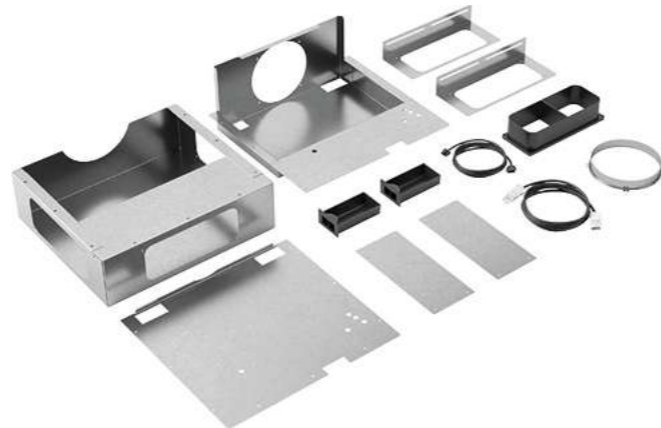

Ceiling hoods



iQ500 LR96CAQ50B

Ceiling hood – Flat Motor Design
Stainless steel

90cm

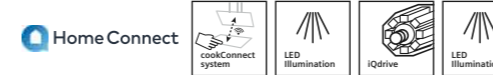

Ceiling hood specifications

APPLIANCE TYPE	CEILING FLAT MOTOR	CEILING	CEILING COMPACT MOTOR
Design family	iQ500	iQ500	iQ500
Model number	LR96CAQ50B	LR97CAQ50B	LR97CAP21B
Colour	Stainless steel	Stainless steel	Stainless steel
KEY FEATURES			
emotionLight Pro	–	–	–
Home Connect	■	■	–
cookConnect hob based hood control	■	■	–
climateControl sensor	–	–	–
Adjustable LED white colour temperature	–	–	–
Reduced size motor	Flat	–	Compact
iQdrive®	■	■	■
Intensive setting / Automatic intensive revert ¹	■ / ■	■ / ■	■ / ■
Grease / charcoal filter saturation indicators	■ / ■	■ / ■	■ / ■
FEATURES			
Suitable for ducted / recirculating operation	■ / ■	■ / ■	■ / ■
Type of control	Remote control	Remote control	Remote control
Power levels	3 + 2 intensive	3 + 2 intensive	3 + 1 intensive
Electronic power level display	–	–	–
Interval operation	■	■	■
Automatic after running (minutes)	10	10	10
Lighting	4 x LED lights	4 x LED lights	4 x LED lights
softLight with dimmer function	■	■	■
Number of metal grease filter cassettes	2	2	2
PERFORMANCE / TECHNICAL INFORMATION			
Appliance width (mm)	900	900	900
Extraction Rate in m³/h^{2,4}			
– ducted / recirculating at power level 1	252 / 198	265 / 200	190 / 167
– ducted / recirculating at power level 2	336 / 257	335 / 316	265 / 221
– ducted / recirculating at power level 3	434 / 336	458 / 422	400 / 423
– ducted / recirculating at power level 4 or intensive setting 1	581 / 466	594 / 513	–
– ducted / recirculating, intensive setting or intensive setting 2	734 / 574	798 / 565	690 / 588
Noise level (sound power) based on dB [A] re 1pW^{4,5}			
– ducted / recirculating at power level 1	47 / 48	41 / 46	48 / 50
– ducted / recirculating at power level 2	55 / 55	47 / 57	55 / 58
– ducted / recirculating at power level 3	61 / 61	56 / 63	65 / 69
– ducted / recirculating at power level 4 or intensive setting 1	68 / 71	62 / 67	–
– ducted / recirculating, intensive setting or intensive setting 2	72 / 74	68 / 69	73 / 74
Pipe outlet diameter (mm)	150	150	150
Minimum distance above an electric / gas hob ⁶ (mm)	650/650	650/650	650/900
GB plug	■	■	■
Energy rating	A	A	B
OPTIONAL ACCESSORIES⁶			
Recirculation Filter Kit	–	–	–
CleanAir Recirculating Flat Module (Stainless Steel)	LZ21JXC51	–	LZ21JXC51
CleanAir Recirculating Flat Module (White)	LZ21JXC21	–	LZ21JXC21
CleanAir Plus Recirculating Module (Stainless Steel)	–	LZ21JCC56	–
CleanAir Plus Recirculating Module (White)	–	LZ21JCC26	–
Long Life Regenerative Recirculation Module (Stainless Steel)	–	LZ20JCD50	–
Long Life Regenerative Recirculation Module (White)	–	LZ20JCD20	–
Replacement cleanAir Plus Anti-Pollen Filter (12 month lifespan) for: LR97CAQ50B	–	LZ31XX816	–

■ Yes, model has this feature. – Feature not available for this model.
¹Power automatically reverts back to normal setting after intensive.
²Air Flow and noise declarations made in line with CECEC Code of Conduct.
³Measured according to EN61591 on largest pipe diameter.
⁴Sound power measured according to EN60704-3 on largest pipe diameter.
⁵From top of pan supports.
⁶A type of recirculating kit is required if recirculating. Depending on the model, a 'Recirculating odour filter kit' will consist of the following items: Charcoal filter, flexible hose, air duct, fixing components, installation instructions.
Data valid in this table as of June 2022. Subject to modification without prior notice.



Flat or compact motor?

Flat motor

The flat motor ceiling hoods benefit from a lower profile and flush fit, allowing a lower 200mm built-in height compared to a standard motor, which helps it to seamlessly fit into your ceiling. They are the perfect choice for those who want a sleek and discreet design.

Compact motor

The compact design of these hoods allow for easy installation between existing ceiling joists. Their motor rotates in 4 directions for added fitting flexibility.

Island hoods



Model shown: LF91BUV50B island hood

iQ700 LF91BUV50B

Island hood
Stainless steel



Home Connect

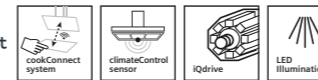

2
Year Warranty

Home Connect



Island hood specifications

APPLIANCE TYPE	ISLAND	
	iQ700	iQ800
Design family	LF91BUV50B	LF97GBM50B
Model number	LF91BUV50B	LF97GBM50B
Colour	Stainless steel	Stainless steel & glass
KEY FEATURES		
emotionLight Pro	-	-
Home Connect	■	-
cookConnect hob based hood control	■	-
climateControl sensor	■	-
Adjustable LED white colour temperature	-	-
iQdrive®	■	-
Intensive setting / Automatic intensive revert ¹	■ / ■	■ / ■
Grease / charcoal filter saturation indicators	■ / ■	- / -
FEATURES		
Suitable for ducted / recirculating operation	■ / ■	■ / ■
Type of control	Touch control	Touch control
Power levels	3 + 2 intensive	3 + 1 intensive
Electronic power level display	■	-
Interval operation	-	-
Automatic after running (minutes)	10	-
Lighting	4 x LED lights	4 x LED lights
softLight with dimmer function	■	■
Number of metal grease filter cassettes	3	2
PERFORMANCE / TECHNICAL INFORMATION		
Appliance width (mm)	898	898
Extraction Rate in m ³ /h ^{2,3}		
- ducted / recirculating at power level 1	283 / 171	243 / 173
- ducted / recirculating at power level 2	443 / 315	328 / 253
- ducted / recirculating at power level 3	597 / 359	429 / 315
- ducted / recirculating at power level 4 or intensive setting 1	815 / 392	- / -
- ducted / recirculating, intensive setting or intensive setting 2	980 / 427	732 / 384
Noise level (sound power) based on dB [A] re 1pW ^{2,4}		
- ducted / recirculating at power level 1	43 / 59	47 / 62
- ducted / recirculating at power level 2	55 / 69	54 / 69
- ducted / recirculating at power level 3	62 / 72	60 / 73
- ducted / recirculating at power level 4 or intensive setting 1	69 / 74	- / -
- ducted / recirculating, intensive setting or intensive setting 2	73 / 76	71 / 77
Pipe outlet diameter (mm)	150 / 120	150 / 120
Minimum distance above an electric / gas hob ⁵ (mm)	550 / 650	550 / 650
GB plug	■	■
Energy rating	A+	B
OPTIONAL ACCESSORIES ⁶		
CleanAir Standard Recirculation Kit	LZ22CB114	LZ21CG114
1600mm chimney extension for Island Extractors	LZ12385	
1100mm chimney extension for Island Extractors		LZ12285
1000mm mounting kit extension for Island Extractors	LZ12530	
500mm mounting kit extension for Island Extractors	LZ12510	
CleanAir Plus External Recirculation Module (Stainless Steel)	LZ22CX56	LZ21CX56
Long Life External Recirculation Module (Stainless Steel)	LZ22FXD51	-

■ Yes, model has this feature. - Feature not available for this model.

¹Power automatically reverts back to normal setting after intensive.

²Air Flow and noise declarations made in line with CECEC Code of Conduct.

³Measured according to EN61591 on largest pipe diameter.

⁴Sound power measured according to EN60704-3 on largest pipe diameter.

⁵From top of pan supports.

⁶A type of recirculating kit is required if recirculating. Depending on the model, a 'Recirculating odour filter kit' will consist of the following items: Charcoal filter, flexible hose, air duct, fixing components, installation instructions.

Data valid in this table as of June 2022. Subject to modification without prior notice.

For specification details, please visit siemens-home.bsh-group.com/uk and download a full specification sheet.

For the full range of accessories, please visit our online accessory shop at siemens-home.bsh-group.com/uk/shop or call our Spares Department on 0344 892 8999.

Decorative hoods

iQ 700 LC91KWW60B

Angled glass chimney hood
Black glass

90cm



Angled hood specifications

APPLIANCE TYPE	ANGLED GLASS CHIMNEY HOOD
Design family	iQ 700
Model number	LC91KWW60B
Colour	Black glass
KEY FEATURES	
emotionLight Pro	■
Home Connect	■
cookConnect hob based hood control	■
climateControl sensor	■
Adjustable LED white colour temperature	-
iQdrive®	■
Intensive setting / Automatic intensive revert ¹	■ / ■
Grease / charcoal filter saturation indicators	■ / ■
FEATURES	
Suitable for ducted / recirculating operation	■ / ■
Type of control	Touch Control
Power levels	3 + 2 intensive
Electronic power level display	■
Interval operation	-
Automatic after running (minutes)	10
Lighting	2 x LED lights
softLight with dimmer function	■
Number of metal grease filter cassettes	2
PERFORMANCE / TECHNICAL INFORMATION	
Appliance width (mm)	890
Extraction Rate in m³/h ^{2,3}	
- ducted / recirculating at power level 1	293 / 199
- ducted / recirculating at power level 2	393 / 347
- ducted / recirculating at power level 3	525 / 447
- ducted / recirculating at power level 4 or intensive setting 1	712 / 539
- ducted / recirculating, intensive setting or intensive setting 2	991 / 624
Noise level (sound power) based on dB [A] re 1pW ^{3,4}	
- ducted / recirculating at power level 1	45 / 51
- ducted / recirculating at power level 2	50 / 63
- ducted / recirculating at power level 3	58 / 69
- ducted / recirculating at power level 4 or intensive setting 1	65 / 74
- ducted / recirculating, intensive setting or intensive setting 2	71 / 78
Pipe outlet diameter (mm)	150 / 120
Minimum distance above an electric / gas hob ⁵ (mm)	450 / 600
GB plug	■
Energy rating	A+
OPTIONAL ACCESSORIES ⁶	
Standard Recirculation Kit	LZ10AKU00
Standard Recirculation Kit (Chimless Installation)	LZ10AKT00
cleanAir Plus Anti-Pollen Recirculation Kit	LZ11AKI16
cleanAir Plus Anti-Pollen Recirculation Kit (Chimless Installation)	LZ11AKV16
Long Life Regenerative Recirculation Kit	LZ10AKS00
Long Life Regenerative Recirculation Kit (Chimless Installation)	LZ10AKR00
Black Chimney	LZ11AXE61

■ Yes, model has this feature. – Feature not available for this model.

¹Power automatically reverts back to normal setting after intensive.

²Air Flow and noise declarations made in line with CECED Code of Conduct.

³Measured according to EN61591 on largest pipe diameter.

⁴Sound power measured according to EN60704-3 on largest pipe diameter.

⁵From top of pan supports.

⁶A type of recirculating kit is required if recirculating. Depending on the model, a 'Recirculating odour filter kit' will consist of the following items: Charcoal filter, flexible hose, air duct, fixing components, installation instructions.

Data valid in this table as of June 2022. Subject to modification without prior notice.

Home Connect



Angled hood specifications

APPLIANCE TYPE	ANGLED GLASS CHIMNEY HOODS	
Design family	iQ 300	iQ 300
Model number	LC87KHM60B	LC67KHM60B
Colour	Black glass	Black glass
KEY FEATURES		
emotionLight Pro	-	-
Home Connect	-	-
cookConnect hob based hood control	-	-
climateControl sensor	-	-
Adjustable LED white colour temperature	-	-
iQdrive	-	-
Intensive setting / Automatic intensive revert ¹	■ / ■	■ / ■
Grease / charcoal filter saturation indicators	- / -	- / -
FEATURES		
Suitable for ducted / recirculating operation	■ / ■	■ / ■
Type of control	Touch Control	Touch Control
Power levels	3 + 1 intensive	3 + 1 intensive
Electronic power level display	-	-
Interval operation	-	-
Automatic after running (minutes)	-	-
Lighting	2 x LED lights	2 x LED lights
softLight with dimmer function	-	-
Number of metal grease filter cassettes	2	2
PERFORMANCE / TECHNICAL INFORMATION		
Appliance width (mm)	790	590
Extraction Rate in m³/h ^{2,3}		
- ducted / recirculating at power level 1	253 / 218	253 / 218
- ducted / recirculating at power level 2	332 / 293	332 / 293
- ducted / recirculating at power level 3	416 / 388	416 / 388
- ducted / recirculating at power level 4 or intensive setting 1	- / -	- / -
- ducted / recirculating, intensive setting or intensive setting 2	700 / 557	700 / 557
Noise level (sound power) based on dB [A] re 1pW ^{3,4}		
- ducted / recirculating at power level 1	48 / 55	48 / 55
- ducted / recirculating at power level 2	53 / 60	53 / 60
- ducted / recirculating at power level 3	58 / 66	58 / 66
- ducted / recirculating at power level 4 or intensive setting 1	- / -	- / -
- ducted / recirculating, intensive setting or intensive setting 2	67 / 75	67 / 75
Pipe outlet diameter (mm)	150 / 120	150 / 120
Minimum distance above an electric / gas hob ⁵ (mm)	450 / 600	450 / 600
GB plug	■	■
Energy rating	B	B
OPTIONAL ACCESSORIES ⁶		
cleanAir Plus Anti-Pollen Recirculation Kit	LZ11AKI16	LZ11AKI16
cleanAir Plus Anti-Pollen Recirculation Kit (Chimless Installation)	LZ11AKV16	LZ11AKV16
Long Life Regenerative Recirculation Kit	LZ10AKS00	LZ10AKS00
Long Life Regenerative Recirculation Kit (Chimless Installation)	LZ10AKR00	LZ10AKR00
Black Chimney	LZ11AXE61	LZ11AXE61

■ Yes, model has this feature. – Feature not available for this model.

¹Power automatically reverts back to normal setting after intensive.

²Air Flow and noise declarations made in line with CECED Code of Conduct.

³Measured according to EN61591 on largest pipe diameter.

⁴Sound power measured according to EN60704-3 on largest pipe diameter.

⁵From top of pan supports.

⁶A type of recirculating kit is required if recirculating. Depending on the model, a 'Recirculating odour filter kit' will consist of the following items: Charcoal filter, flexible hose, air duct, fixing components, installation instructions.

Data valid in this table as of June 2022. Subject to modification without prior notice.

Box chimney hoods

iQ 700 LC91BUV50B

Box chimney hood
Stainless steel

90cm



2
Year Warranty



Home Connect



APPLIANCE TYPE	BOX CHIMNEY HOOD
Design family	iQ 700
Model number	LC91BUV50B
Colour	Stainless steel
KEY FEATURES	
emotionLight Pro	–
Home Connect	■
cookConnect hob based hood control	■
climateControl sensor	■
Adjustable LED white colour temperature	–
iQdrive®	■
Intensive setting / Automatic intensive revert ¹	■ / ■
Grease / charcoal filter saturation indicators	■ / ■
FEATURES	
Suitable for ducted / recirculating operation	■ / ■
Type of control	Touch control
Power levels	3 + 2 intensive
Electronic power level display	■
Interval operation	–
Automatic after running (minutes)	10
Lighting	3 x LED lights
softLight with dimmer function	■
Number of metal grease filter cassettes	3
PERFORMANCE / TECHNICAL INFORMATION	
Appliance width (mm)	898
Extraction Rate in m³/h ^{2,3}	
– ducted / recirculating at power level 1	276 / 175
– ducted / recirculating at power level 2	436 / 320
– ducted / recirculating at power level 3	601 / 362
– ducted / recirculating at power level 4 or intensive setting 1	800 / 395
– ducted / recirculating, intensive setting or intensive setting 2	964 / 428
Noise level (sound power) based on dB [A] re 1pW ^{2,4}	
– ducted / recirculating at power level 1	45 / 58
– ducted / recirculating at power level 2	56 / 70
– ducted / recirculating at power level 3	64 / 73
– ducted / recirculating at power level 4 or intensive setting 1	70 / 74
– ducted / recirculating, intensive setting or intensive setting 2	73 / 76
Pipe outlet diameter (mm)	150 / 120
Minimum distance above an electric / gas hob ⁵ (mm)	550 / 650
GB plug	■
Energy rating	A+
OPTIONAL ACCESSORIES ⁶	
Standard Recirculation Kit	LZ53450
CleanAir Plus External Recirculation Module (Stainless Steel)	LZ12CX56
CleanAir Plus Integrated Recirculation Kit	LZ11CX16
Long Life Regenerative Integrated Recirculation Kit	LZ10FXJ05

■ Yes, model has this feature. – Feature not available for this model.

¹Power automatically reverts back to normal setting after intensive.

²Air Flow and noise declarations made in line with CECEC Code of Conduct.

³Measured according to EN61591 on largest pipe diameter.

⁴Sound power measured according to EN60704-3 on largest pipe diameter.

⁵From top of pan supports.

⁶A type of recirculating kit is required if recirculating. Depending on the model, a 'Recirculating odour filter kit' will consist of the following items: Charcoal filter, flexible hose, air duct, fixing components, installation instructions.

Data valid in this table as of June 2022. Subject to modification without prior notice.

Box hood specifications



APPLIANCE TYPE	BOX CHIMNEY HOODS				
Design family	iQ 300	iQ 300	iQ 300	iQ 100	iQ 100
Model number	LC97BHM50B	LC77BHM50B	LC67BHM50B	LC94BBC50B	LC64BBC50B
Colour	Stainless steel	Stainless steel	Stainless steel	Stainless steel	Stainless steel
KEY FEATURES					
emotionLight Pro	–	–	–	–	–
Home Connect	–	–	–	–	–
cookConnect hob based hood control	–	–	–	–	–
climateControl sensor	–	–	–	–	–
Adjustable LED white colour temperature	–	–	–	–	–
iQdrive®	–	–	–	–	–
Intensive setting / Automatic intensive revert ¹	■ / ■	■ / ■	■ / ■	– / –	– / –
Grease / charcoal filter saturation indicators	– / –	– / –	– / –	– / –	– / –
FEATURES					
Suitable for ducted / recirculating operation	■ / ■	■ / ■	■ / ■	■ / ■	■ / ■
Type of control	Touch control	Touch control	Touch control	Push button control	Push button control
Power levels	3 + 1 intensive	3 + 1 intensive	3 + 1 intensive	3	3
Electronic power level display	–	–	–	–	–
Interval operation	–	–	–	–	–
Automatic after running (minutes)	–	–	–	–	–
Lighting	2 x LED lights	2 x LED lights	2 x LED lights	2 x LED lights	2 x LED lights
softLight with dimmer function	–	–	–	–	–
Number of metal grease filter cassettes	3	2	2	3	2
PERFORMANCE / TECHNICAL INFORMATION					
Appliance width (mm)	900	750	600	900	600
Extraction Rate in m³/h ^{2,3}					
– ducted / recirculating at power level 1	266 / 187	266 / 187	269 / 183	198 / 120	198 / 122
– ducted / recirculating at power level 2	345 / 270	345 / 270	342 / 262	263 / 162	263 / 165
– ducted / recirculating at power level 3	453 / 324	453 / 324	458 / 321	365 / 195	365 / 197
– ducted / recirculating at power level 4 or intensive setting 1	– / –	– / –	– / –	– / –	– / –
– ducted / recirculating, intensive setting or intensive setting 2	739 / 379	739 / 379	752 / 379	– / –	– / –
Noise level (sound power) based on dB [A] re 1pW ^{2,4}					
– ducted / recirculating at power level 1	52 / 63	52 / 63	52 / 63	49 / 55	49 / 56
– ducted / recirculating at power level 2	58 / 70	58 / 70	57 / 70	57 / 61	57 / 61
– ducted / recirculating at power level 3	65 / 74	65 / 74	64 / 73	64 / 66	63 / 66
– ducted / recirculating at power level 4 or intensive setting 1	– / –	– / –	– / –	– / –	– / –
– ducted / recirculating, intensive setting or intensive setting 2	74 / 77	74 / 77	73 / 76	– / –	– / –
Pipe outlet diameter (mm)	150 / 120	150 / 120	150 / 120	150 / 120	150 / 120
Minimum distance above an electric / gas hob ⁵ (mm)	550 / 650	550 / 650	550 / 650	550 / 650	550 / 650
GB plug	■	■	■	■	■
Energy rating	B	B	B	D	D
OPTIONAL ACCESSORIES ⁶					
Standard Recirculation Kit	LZ10DXU00	LZ10DXU00	LZ10DXU00	LZ10DXU00	LZ10DXU00
CleanAir Plus External Recirculation Module (Stainless Steel)	LZ11FXC56	LZ11FXC56	LZ11FXC56	LZ11FXC56	LZ11FXC56
CleanAir Plus Integrated Recirculation Kit	LZ11DXI16	LZ11DXI16	LZ11DXI16	LZ11DXI16	LZ11DXI16
Long Life Regenerative Integrated Recirculation Kit	LZ10FXJ00	LZ10FXJ00	LZ10FXJ00	LZ10FXJ00	LZ10FXJ00

■ Yes, model has this feature. – Feature not available for this model.

¹Power automatically reverts back to normal setting after intensive.

²Air Flow and noise declarations made in line with CECEC Code of Conduct.

³Measured according to EN61591 on largest pipe diameter.

⁴Sound power measured according to EN60704-3 on largest pipe diameter.

⁵From top of pan supports.

⁶A type of recirculating kit is required if recirculating. Depending on the model, a 'Recirculating odour filter kit' will consist of the following items: Charcoal filter, flexible hose, air duct, fixing components, installation instructions.

Data valid in this table as of June 2022. Subject to modification without prior notice.

Glass chimney hoods

iQ300 LC97AFM50B

Curved glass chimney hood
Stainless steel

90cm



Glass hood specifications



APPLIANCE TYPE	CURVED GLASS HOODS	
	iQ300	iQ300
Design family	LC97AFM50B	LC67AFM50B
Model number	LC97AFM50B	LC67AFM50B
Colour	Stainless steel & glass	Stainless steel & glass
KEY FEATURES		
emotionLight Pro	–	–
Home Connect	–	–
cookConnect hob based hood control	–	–
climateControl sensor	–	–
Adjustable LED white colour temperature	–	–
iQdrive®	–	–
Intensive setting / Automatic intensive revert ¹	■ / ■	■ / ■
Grease / charcoal filter saturation indicators	– / –	– / –
FEATURES		
Suitable for ducted / recirculating operation	■ / ■	■ / ■
Type of control	Touch control	Touch control
Power levels	3 + 1 intensive	3 + 1 intensive
Electronic power level display	–	–
Interval operation	–	–
Automatic after running (minutes)	–	–
Lighting	2 x LED lights	2 x LED lights
softLight with dimmer function	–	–
Number of metal grease filter cassettes	1	1
PERFORMANCE / TECHNICAL INFORMATION		
Appliance width (mm)	900	600
Extraction Rate in m³/h ^{2,3}		
- ducted / recirculating at power level 1	260 / 202	266 / 213
- ducted / recirculating at power level 2	343 / 276	349 / 285
- ducted / recirculating at power level 3	463 / 327	474 / 331
- ducted / recirculating at power level 4 or intensive setting 1	– / –	– / –
- ducted / recirculating, intensive setting or intensive setting 2	702 / 380	715 / 379
Noise level (sound power) based on dB [A] re 1pW ^{2,4}		
- ducted / recirculating at power level 1	54 / 63	54 / 65
- ducted / recirculating at power level 2	60 / 70	61 / 70
- ducted / recirculating at power level 3	67 / 74	67 / 73
- ducted / recirculating at power level 4 or intensive setting 1	– / –	– / –
- ducted / recirculating, intensive setting or intensive setting 2	74 / 77	74 / 76
Pipe outlet diameter (mm)	150 / 120	150 / 120
Minimum distance above an electric / gas hob ⁵ (mm)	550 / 650	550 / 650
GB plug	■	■
Energy rating	B	B
OPTIONAL ACCESSORIES ⁶		
CleanAir Plus External Recirculation Module (Stainless Steel)	LZ11FXC56	LZ11FXC56
CleanAir Plus Integrated Recirculation Kit	LZ11DXI16	LZ11DXI16
Long Life Regenerative Integrated Recirculation Kit	LZ10FXJ00	LZ10FXJ00

■ Yes, model has this feature. – Feature not available for this model.

¹Power automatically reverts back to normal setting after intensive.

²Air Flow and noise declarations made in line with CECED Code of Conduct.

³Measured according to EN61591 on largest pipe diameter.

⁴Sound power measured according to EN60704-3 on largest pipe diameter.

⁵From top of pan supports.

⁶A type of recirculating kit is required if recirculating. Depending on the model, a 'Recirculating odour filter kit' will consist of the following items: Charcoal filter, flexible hose, air duct, fixing components, installation instructions.

Data valid in this table as of June 2022. Subject to modification without prior notice.

Model shown:
LC97AFM50B curved glass chimney hood

Pyramid hoods

iQ300 LC97QFM50B

Slim pyramid chimney hood
Stainless steel

90cm



Pyramid hoods
A contemporary take on a classic design the Siemens slim pyramid hood with a gentle pyramid slope is the perfect addition to your kitchen.

Pyramid hood specifications

APPLIANCE TYPE	SLIM PYRAMID HOOD
Design family	iQ300
Model number	LC97QFM50B
Colour	Stainless steel
KEY FEATURES	
emotionLight Pro	-
Home Connect	-
cookConnect hob based hood control	-
climateControl sensor	-
Adjustable LED white colour temperature	-
iQdrive®	-
Intensive setting / Automatic intensive revert ¹	■ / ■
Grease / charcoal filter saturation indicators	- / -
FEATURES	
Suitable for ducted / recirculating operation	■ / ■
Type of control	Touch control
Power levels	3 + 1 intensive
Electronic power level display	-
Interval operation	-
Automatic after running (minutes)	-
Lighting	2 x LED lights
softLight with dimmer function	-
Number of metal grease filter cassettes	3
PERFORMANCE / TECHNICAL INFORMATION	
Appliance width (mm)	900
Extraction Rate in m³/h ^{2,3}	
- ducted / recirculating at power level 1	279 / 198
- ducted / recirculating at power level 2	353 / 283
- ducted / recirculating at power level 3	462 / 346
- ducted / recirculating at power level 4 or intensive setting 1	- / -
- ducted / recirculating, intensive setting or intensive setting 2	779 / 397
Noise level (sound power) based on dB [A] re 1pW ^{4,4}	
- ducted / recirculating at power level 1	50 / 64
- ducted / recirculating at power level 2	57 / 71
- ducted / recirculating at power level 3	64 / 74
- ducted / recirculating at power level 4 or intensive setting 1	- / -
- ducted / recirculating, intensive setting or intensive setting 2	73 / 77
Pipe outlet diameter (mm)	150 / 120
Minimum distance above an electric / gas hob ⁵ (mm)	550 / 650
GB plug	■
Energy rating	B
OPTIONAL ACCESSORIES ⁶	
Standard Recirculation Kit	LZ12CBI14, LZ11DXI14
CleanAir Plus External Recirculation Module (Stainless Steel)	LZ11FXC56
CleanAir Plus Integrated Recirculation Kit	LZ11DXI16
Long Life Regenerative Integrated Recirculation Kit	LZ10FXJ00
Long Life Regenerative Chimless Recirculation Kit	
CleanAir Plus Anti-Pollen Recirculation Kit	
CleanAir Plus Anti-Pollen Internal Recirculation Kit	LZ11DXI16
Black Chimney (for Angled and Flat Glass Chimney Hoods)	
Stainless steel splash back panel: 900 x 720mm	
Stainless steel splash back panel: 700 x 720mm	
Stainless steel splash back panel: 600 x 720mm	

■ Yes, model has this feature. - Feature not available for this model.
¹Power automatically reverts back to normal setting after intensive.
²Air flow and noise declarations made in line with CECEC Code of Conduct.
³Measured according to EN61591 on largest pipe diameter.
⁴Sound power measured according to EN60704-3 on largest pipe diameter.
⁵From top of pan supports.
⁶A type of recirculating kit is required if recirculating. Depending on the model, a 'Recirculating odour filter kit' will consist of the following items: Charcoal filter, flexible hose, air duct, fixing components, installation instructions.

Data valid in this table as of June 2022. Subject to modification without prior notice.

Pyramid hood specifications

APPLIANCE TYPE	SLIM PYRAMID HOOD	PYRAMID HOOD	PYRAMID HOOD
Design family	iQ300	iQ100	iQ100
Model number	LC67QFM50B	LC94PBC50B	LC64PBC50B
Colour	Stainless steel	Stainless steel	Stainless steel
KEY FEATURES			
emotionLight Pro	-	-	-
Home Connect	-	-	-
cookConnect hob based hood control	-	-	-
climateControl sensor	-	-	-
Adjustable LED white colour temperature	-	-	-
iQdrive®	-	-	-
Intensive setting / Automatic intensive revert ¹	■ / ■	- / -	- / -
Grease / charcoal filter saturation indicators	- / -	- / -	- / -
FEATURES			
Suitable for ducted / recirculating operation	■ / ■	■ / ■	■ / ■
Type of control	Touch control	Push button control	Push button control
Power levels	3 + 1 intensive	3	3
Electronic power level display	-	-	-
Interval operation	-	-	-
Automatic after running (minutes)	-	-	-
Lighting	2 x LED lights	2 x LED lights	2 x LED lights
softLight with dimmer function	-	-	-
Number of metal grease filter cassettes	2	3	2
PERFORMANCE / TECHNICAL INFORMATION			
Appliance width (mm)	600	900	600
Extraction Rate in m³/h ^{2,3}			
- ducted / recirculating at power level 1	262 / 192	198 / 129	198 / 127
- ducted / recirculating at power level 2	339 / 275	263 / 174	263 / 171
- ducted / recirculating at power level 3	445 / 332	365 / 213	365 / 211
- ducted / recirculating at power level 4 or intensive setting 1	- / -	- / -	- / -
- ducted / recirculating, intensive setting or intensive setting 2	747 / 389	- / -	- / -
Noise level (sound power) based on dB [A] re 1pW ^{4,4}			
- ducted / recirculating at power level 1	53 / 58	50 / 56	50 / 55
- ducted / recirculating at power level 2	59 / 68	57 / 62	58 / 62
- ducted / recirculating at power level 3	65 / 72	65 / 67	66 / 67
- ducted / recirculating at power level 4 or intensive setting 1	- / -	- / -	- / -
- ducted / recirculating, intensive setting or intensive setting 2	73 / 76	- / -	- / -
Pipe outlet diameter (mm)	150 / 120	150 / 120	150 / 120
Minimum distance above an electric / gas hob ⁵ (mm)	550 / 650	550 / 650	550 / 650
GB plug	■	■	■
Energy rating	B	D	D
OPTIONAL ACCESSORIES ⁶			
Standard Recirculation Kit	LZ12CBI14, LZ11DXI14	LZ52750	LZ52750
CleanAir Plus External Recirculation Module (Stainless Steel)	LZ11FXC56	-	-
CleanAir Plus Integrated Recirculation Kit	LZ11DXI16	-	-
Long Life Regenerative Integrated Recirculation Kit	LZ10FXJ00	-	-
Long Life Regenerative Chimless Recirculation Kit	LZ10AKR00		
CleanAir Plus Anti-Pollen Recirculation Kit for			
CleanAir Plus Anti-Pollen Internal Recirculation Kit	LZ11DXI16	LZ11DXI16	
Black Chimney (for Angled and Flat Glass Chimney Hoods)			
Stainless steel splash back panel: 900 x 720mm			
Stainless steel splash back panel: 700 x 720mm			
Stainless steel splash back panel: 600 x 720mm			

■ Yes, model has this feature. - Feature not available for this model.
¹Power automatically reverts back to normal setting after intensive.
²Air flow and noise declarations made in line with CECEC Code of Conduct.
³Measured according to EN61591 on largest pipe diameter.
⁴Sound power measured according to EN60704-3 on largest pipe diameter.
⁵From top of pan supports.
⁶A type of recirculating kit is required if recirculating. Depending on the model, a 'Recirculating odour filter kit' will consist of the following items: Charcoal filter, flexible hose, air duct, fixing components, installation instructions.

Data valid in this table as of June 2022. Subject to modification without prior notice.

Integrated design hoods

iQ500 LJ97BAM60B

Integrated extractor hood
Black body & fold out glass

90cm

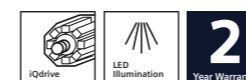

Integrated design hood specifications

APPLIANCE TYPE	INTEGRATED DESIGN HOODS	
Design family	iQ500	iQ500
Model number	LJ97BAM60B	LJ67BAM60B
Colour	Black body & fold out glass	Black body & fold out glass
KEY FEATURES		
emotionLight Pro	–	–
Home Connect	–	–
cookConnect hob based hood control	–	–
climateControl sensor	–	–
Adjustable LED white colour temperature	–	–
iQdrive®	■	–
Intensive setting / Automatic intensive revert ¹	■ / ■	■ / ■
Grease / charcoal filter saturation indicators	■ / ■	■ / ■
FEATURES		
Suitable for ducted / recirculating operation	■ / ■	■ / ■
Type of control	Touch control	Touch control
Power levels	3 + 1 intensive	3 + 1 intensive
Electronic power level display	–	–
Interval operation	–	–
Automatic after running (minutes)	10	10
Lighting	3 x 2 W LED lights	2 x LED lights
softLight with dimmer function	■	■
Number of metal grease filter cassettes	2	2
PERFORMANCE / TECHNICAL INFORMATION		
Appliance width (mm)	860	560
Extraction Rate in m³/h ^{2,3}		
– ducted / recirculating at power level 1	265 / 227	265 / 227
– ducted / recirculating at power level 2	355 / 319	355 / 319
– ducted / recirculating at power level 3	460 / 396	460 / 396
– ducted / recirculating at power level 4 or intensive setting 1	– / –	– / –
– ducted / recirculating, intensive setting or intensive setting 2	749 / 652	749 / 652
Noise level (sound power) based on dB [A] re 1 pW ^{2,4}		
– ducted / recirculating at power level 1	50 / 59	50 / 59
– ducted / recirculating at power level 2	57 / 67	57 / 67
– ducted / recirculating at power level 3	63 / 72	63 / 72
– ducted / recirculating at power level 4 or intensive setting 1	– / –	– / –
– ducted / recirculating, intensive setting or intensive setting 2	73 / 77	73 / 77
Pipe outlet diameter (mm)	150 / 120	150 / 120
Minimum distance above an electric / gas hob ⁵ (mm)	430 / 650	430 / 650
GB plug	■	■
Energy rating	B	B
OPTIONAL ACCESSORIES⁶		
Standard Recirculation Filter / Kit	LZ101MA00	LZ101MA00
Long Life Regenerative Recirculation Kit	LZ111TD11	LZ111TD11
cleanAir Plus Anti-Pollen Recirculation Kit (filter with 12 month lifespan)	LZ111XC16	LZ111XC16
CleanAir Standard Recirculation Kit	LZ161BI14	LZ161BI14
Chimney Extension 450-854mm (Used inside cabinet to cover ducting)	LZ111BK61	LZ111BK61
Chimney Extension 187-360mm (Used inside cabinet to cover ducting)	LZ111BN61	LZ111BN61

■ Yes, model has this feature. – Feature not available for this model.

¹Power automatically reverts back to normal setting after intensive.

²Air Flow and noise declarations made in line with CECEC Code of Conduct.

³Measured according to EN61591 on largest pipe diameter.

⁴Sound power measured according to EN60704-3 on largest pipe diameter.

⁵From top of pan supports.

⁶A type of recirculating kit is required if recirculating. Depending on the model, a 'Recirculating odour filter kit' will consist of the following items: Charcoal filter, flexible hose, air duct, fixing components, installation instructions.

Data valid in this table as of June 2022. Subject to modification without prior notice.

Model shown:
LJ97BAM60B integrated extractor hood

Telescopic hoods

iQ 500 LI97SA561B

Telescopic extractor hood
Stainless steel

90cm



2
Year Warranty



Telescopic hood specifications



APPLIANCE TYPE	TELESCOPIC HOOD
Design family	iQ 500
Model number	LI97SA561B
Colour	Stainless steel
KEY FEATURES	
emotionLight Pro	–
Home Connect	–
cookConnect hob based hood control	–
climateControl sensor	–
Adjustable LED white colour temperature	–
iQdrive®	■
Intensive setting / Automatic intensive revert ¹	■ / ■
Grease / charcoal filter saturation indicators	■ / ■
FEATURES	
Suitable for ducted / recirculating operation	■ / ■
Type of control	Soft touch button control
Power levels	3 + 2 intensive
Electronic power level display	–
Interval operation	–
Automatic after running (minutes)	10
Lighting	3 x LED lights
softLight with dimmer function	■
Number of metal grease filter cassettes	3
PERFORMANCE / TECHNICAL INFORMATION	
Appliance width (mm)	898
Extraction Rate in m³/h ^{2,3}	
– ducted / recirculating at power level 1	198 / 155
– ducted / recirculating at power level 2	301 / 242
– ducted / recirculating at power level 3	395 / 321
– ducted / recirculating at power level 4 or intensive setting 1	534 / 442
– ducted / recirculating, intensive setting or intensive setting 2	700 / 543
Noise level (sound power) based on dB [A] re 1pW ^{2,4}	
– ducted / recirculating at power level 1	41 / 44
– ducted / recirculating at power level 2	49 / 56
– ducted / recirculating at power level 3	53 / 63
– ducted / recirculating at power level 4 or intensive setting 1	62 / 71
– ducted / recirculating, intensive setting or intensive setting 2	69 / 73
Pipe outlet diameter (mm)	150 / 120
Minimum distance above an electric / gas hob ⁵ (mm)	430 / 650
GB plug	■
Energy rating	B
OPTIONAL ACCESSORIES ⁴	
CleanAir Plus Anti-Pollen Recirculation Kit	LZ11IXC16
Long Life Regenerative Recirculation Kit	LZ11ITD11
Handle Strip - Black	LZ49561
Handle Strip - White	LZ49521
Lowering frame	LZ49601
Bracket for installation in 90cm wide units	LZ49200
Replacement cleanAir Plus Anti-Pollen Replacement Filter (12 month lifespan)	LZ11IXB16
CleanAir Standard Recirculation Kit	LZ12IT114
CleanAir Standard Recirculation Kit	LZ11IT114

■ Yes, model has this feature. – Feature not available for this model.

¹Power automatically reverts back to normal setting after intensive.

²Air Flow and noise declarations made in line with CECED Code of Conduct.

³Measured according to EN61591 on largest pipe diameter.

⁴Sound power measured according to EN60704-3 on largest pipe diameter.

⁵From top of pan supports.

⁶A type of recirculating kit is required if recirculating. Depending on the model, a 'Recirculating odour filter kit' will consist of the following items: Charcoal filter, flexible hose, air duct, fixing components, installation instructions.

Data valid in this table as of April 2022. Subject to modification without prior notice.

Telescopic hood specifications



APPLIANCE TYPE	TELESCOPIC HOODS	
Design family	iQ 300	iQ 300
Model number	LI94MA531B	LI64MA531B
Colour	Stainless steel	Stainless steel
KEY FEATURES		
emotionLight Pro	–	–
Home Connect	–	–
cookConnect hob based hood control	–	–
climateControl sensor	–	–
Adjustable LED white colour temperature	–	–
iQdrive®	■	■
Intensive setting / Automatic intensive revert ¹	■ / ■	■ / ■
Grease / charcoal filter saturation indicators	– / –	– / –
FEATURES		
Suitable for ducted / recirculating operation	■ / ■	■ / ■
Type of control	Soft touch button control	Soft touch button control
Power levels	3 + 1 intensive	3 + 1 intensive
Electronic power level display	–	–
Interval operation	–	–
Automatic after running (minutes)	10	10
Lighting	3 x LED lights	2 x LED lights
softLight with dimmer function	–	–
Number of metal grease filter cassettes	3	2
PERFORMANCE / TECHNICAL INFORMATION		
Appliance width (mm)	898	598
Extraction Rate in m³/h ^{2,3}		
– ducted / recirculating at power level 1	164 / 106	174 / 103
– ducted / recirculating at power level 2	223 / 140	226 / 139
– ducted / recirculating at power level 3	266 / 166	271 / 174
– ducted / recirculating at power level 4 or intensive setting 1	– / –	– / –
– ducted / recirculating, intensive setting or intensive setting 2	412 / 178	405 / 189
Noise level (sound power) based on dB [A] re 1pW ^{2,4}		
– ducted / recirculating at power level 1	50 / 57	49 / 58
– ducted / recirculating at power level 2	56 / 65	56 / 65
– ducted / recirculating at power level 3	63 / 70	62 / 70
– ducted / recirculating at power level 4 or intensive setting 1	– / –	– / –
– ducted / recirculating, intensive setting or intensive setting 2	70 / 71	69 / 72
Pipe outlet diameter (mm)	150 / 120	150 / 120
Minimum distance above an electric / gas hob ⁵ (mm)	430 / 650	430 / 650
GB plug	■	■
Energy rating	A	A
OPTIONAL ACCESSORIES ⁴		
CleanAir Plus Anti-Pollen Recirculation Kit	–	–
Long Life Regenerative Recirculation Kit	–	–
Handle Strip - Black	LZ49561	LZ46561
Handle Strip - White	LZ49521	LZ46521
Lowering frame	–	–
Bracket for installation in 90cm wide units	–	–
Replacement cleanAir Plus Anti-Pollen Replacement Filter (12 month lifespan)	–	–
CleanAir Standard Recirculation Kit	–	–
CleanAir Standard Recirculation Kit	–	–

■ Yes, model has this feature. – Feature not available for this model.

¹Power automatically reverts back to normal setting after intensive.

²Air Flow and noise declarations made in line with CECED Code of Conduct.

³Measured according to EN61591 on largest pipe diameter.

⁴Sound power measured according to EN60704-3 on largest pipe diameter.

⁵From top of pan supports.

⁶A type of recirculating kit is required if recirculating. Depending on the model, a 'Recirculating odour filter kit' will consist of the following items: Charcoal filter, flexible hose, air duct, fixing components, installation instructions.

Data valid in this table as of April 2022. Subject to modification without prior notice.

Integrated hoods

iQ 100 LE66MAC00B

Integrated extractor hood
Metallic silver

60cm



2
Year Warranty



Integrated hood specifications

APPLIANCE TYPE	INTEGRATED HOODS	
	iQ 100	iQ 100
Design family	LE66MAC00B	LE63MAC00B
Model number	LE66MAC00B	LE63MAC00B
Colour	Silver metallic lacquer	Silver metallic lacquer
KEY FEATURES		
emotionLight Pro	-	-
Home Connect	-	-
cookConnect hob based hood control	-	-
climateControl sensor	-	-
Adjustable LED white colour temperature	-	-
iQdrive®	-	-
Intensive setting / Automatic intensive revert ¹	- / -	- / -
Grease / charcoal filter saturation indicators	- / -	- / -
FEATURES		
Suitable for ducted / recirculating operation	■ / ■	■ / ■
Type of control	Push button control	Push button control
Power levels	3	3
Electronic power level display	-	-
Interval operation	-	-
Automatic after running (minutes)	-	-
Lighting	2 x LED lights	2 x LED lights
softLight with dimmer function	-	-
Number of metal grease filter cassettes	2	2
PERFORMANCE / TECHNICAL INFORMATION		
Appliance width (mm)	599	599
Extraction Rate in m³/h ^{2,3}		
- ducted / recirculating at power level 1	256 / 208	240 / 224
- ducted / recirculating at power level 2	352 / 320	288 / 256
- ducted / recirculating at power level 3	625 / 416	368 / 272
- ducted / recirculating at power level 4 or intensive setting 1	- / -	- / -
- ducted / recirculating, intensive setting or intensive setting 2	- / -	- / -
Noise level (sound power) based on dB [A] re 1pW ^{3,4}		
- ducted / recirculating at power level 1	49 / 57	52 / 64
- ducted / recirculating at power level 2	56 / 68	56 / 67
- ducted / recirculating at power level 3	70 / 75	62 / 68
- ducted / recirculating at power level 4 or intensive setting 1	- / -	- / -
- ducted / recirculating, intensive setting or intensive setting 2	- / -	- / -
Pipe outlet diameter (mm)	150 / 120	150 / 120
Minimum distance above an electric / gas hob ⁵ (mm)	500 / 650	500 / 650
GB plug	■	■
Energy rating	B	D
OPTIONAL ACCESSORIES ⁶		
Standard Recirculation Filter / Kit	LZ101MA00	LZ101MA00

■ Yes, model has this feature. - Feature not available for this model.

¹Power automatically reverts back to normal setting after intensive.

²Air Flow and noise declarations made in line with CECEC Code of Conduct.

³Measured according to EN61591 on largest pipe diameter.

⁴Sound power measured according to EN60704-3 on largest pipe diameter.

⁵From top of pan supports.

⁶A type of recirculating kit is required if recirculating. Depending on the model, a 'Recirculating odour filter kit' will consist of the following items: Charcoal filter, flexible hose, air duct, fixing components, installation instructions.

Data valid in this table as of June 2022. Subject to modification without prior notice.

Model shown:
LE66MAC00B integrated extractor hood

Canopy hoods

iQ 700 LB79585MGB

Canopy hood
Stainless steel & black glass

70cm



Canopy hood specifications

APPLIANCE TYPE	CANOPY HOOD
Design family	iQ 700
Model number	LB79585MGB
Colour	Stainless steel
KEY FEATURES	
emotionLight Pro	–
Home Connect	–
cookConnect hob based hood control	–
climateControl sensor	–
Adjustable LED white colour temperature	–
iQdrive®	■
Intensive setting / Automatic intensive revert ¹	■ / ■
Grease / charcoal filter saturation indicators	■ / –
FEATURES	
Suitable for ducted / recirculating operation	■ / ■
Type of control	Soft touch button control
Power levels	3 + 1 intensive
Electronic power level display	–
Interval operation	■
Automatic after running (minutes)	30
Lighting	2 x LED lights
softLight with dimmer function	■
Number of metal grease filter cassettes	2
PERFORMANCE / TECHNICAL INFORMATION	
Appliance width (mm)	700
Extraction Rate in m³/h ^{2,3}	
– ducted / recirculating at power level 1	210 / 170
– ducted / recirculating at power level 2	380 / 250
– ducted / recirculating at power level 3	575 / 310
– ducted / recirculating at power level 4 or intensive setting 1	– / –
– ducted / recirculating, intensive setting or intensive setting 2	775 / 380
Noise level (sound power) based on dB [A] re 1pW ^{2,4}	
– ducted / recirculating at power level 1	46 / 57
– ducted / recirculating at power level 2	55 / 66
– ducted / recirculating at power level 3	64 / 71
– ducted / recirculating at power level 4 or intensive setting 1	– / –
– ducted / recirculating, intensive setting or intensive setting 2	70 / 75
Pipe outlet diameter (mm)	150 / 120
Minimum distance above an electric / gas hob ⁵ (mm)	500 / 650
GB plug	■
Energy rating	A++
OPTIONAL ACCESSORIES⁶	
Standard Recirculation Filter / Kit	LZ55750
CleanAir Plus Anti-Pollen Recirculation Kit	LZ11IXC16
Long Life Regenerative Recirculation Kit	LZ11ITD11

■ Yes, model has this feature. – Feature not available for this model.
¹Power automatically reverts back to normal setting after intensive.
²Air Flow and noise declarations made in line with CECEC Code of Conduct.
³Measured according to EN61591 on largest pipe diameter.
⁴Sound power measured according to EN60704-3 on largest pipe diameter.
⁵From top of pan supports.
⁶A type of recirculating kit is required if recirculating. Depending on the model, a 'Recirculating odour filter kit' will consist of the following items: Charcoal filter, flexible hose, air duct, fixing components, installation instructions.
Data valid in this table as of June 2022. Subject to modification without prior notice.

Canopy hood specifications

APPLIANCE TYPE	CANOPY HOODS				
Design family	iQ 500	iQ 500	iQ 300	iQ 300	iQ 100
Model number	LB78574GB	LB57574GB	LB75565GB	LB55565GB	LB53NAA30B
Colour	Stainless steel	Stainless steel	Silver metallic lacquer	Silver metallic lacquer	Silver metallic lacquer
KEY FEATURES					
emotionLight Pro	–	–	–	–	–
Home Connect	–	–	–	–	–
cookConnect hob based hood control	–	–	–	–	–
climateControl sensor	–	–	–	–	–
Adjustable LED white colour temperature	–	–	–	–	–
iQdrive®	–	–	–	–	–
Intensive setting / Automatic intensive revert ¹	■ / ■	■ / ■	■ / –	■ / –	– / –
Grease / charcoal filter saturation indicators	– / –	– / –	– / –	– / –	– / –
FEATURES					
Suitable for ducted / recirculating operation	■ / ■	■ / ■	■ / ■	■ / ■	■ / ■
Type of control	Soft touch button control	Soft touch button control	Slider switch	Slider switch	Push button control
Power levels	3 + 1 intensive	3 + 1 intensive	3 + 1 intensive	3 + 1 intensive	3
Electronic power level display	–	–	–	–	–
Interval operation	–	–	–	–	–
Automatic after running (minutes)	–	–	–	–	–
Lighting	2 x LED lights	2 x LED lights	2 x LED lights	2 x LED lights	2 x LED lights
softLight with dimmer function	–	–	–	–	–
Number of metal grease filter cassettes	2	1	2	2	1
PERFORMANCE / TECHNICAL INFORMATION					
Appliance width (mm)	700	520	730	530	534
Extraction Rate in m³/h ^{2,3}					
– ducted / recirculating at power level 1	345 / 210	295 / 210	198 / 139	196 / 134	120 / 110
– ducted / recirculating at power level 2	540 / 270	450 / 260	287 / 206	280 / 198	160 / 160
– ducted / recirculating at power level 3	630 / 300	560 / 290	379 / 278	362 / 268	300 / 300
– ducted / recirculating at power level 4 or intensive setting 1	– / –	– / –	– / –	– / –	– / –
– ducted / recirculating, intensive setting or intensive setting 2	730 / 310	615 / 300	638 / 408	618 / 395	– / –
Noise level (sound power) based on dB [A] re 1pW ^{2,4}					
– ducted / recirculating at power level 1	53 / 67	50 / 66	38 / 49	38 / 49	46 / 49
– ducted / recirculating at power level 2	63 / 71	63 / 71	49 / 58	49 / 58	50 / 53
– ducted / recirculating at power level 3	66 / 73	67 / 74	56 / 65	56 / 64	61 / 65
– ducted / recirculating at power level 4 or intensive setting 1	– / –	– / –	– / –	– / –	– / –
– ducted / recirculating, intensive setting or intensive setting 2	69 / 74	70 / 75	68 / 72	68 / 72	– / –
Pipe outlet diameter (mm)	150 / 120	150 / 120	150 / 120	150 / 120	120
Minimum distance above an electric / gas hob ⁵ (mm)	500 / 650	500 / 650	650 / 650	650 / 650	650 / 650
GB plug	■	■	■	■	■
Energy rating	C	C	C	C	D
OPTIONAL ACCESSORIES⁶					
Standard Recirculation Filter / Kit	LZ55750	LZ55750	LZ73050	LZ73050	LZ10INT00
CleanAir Plus Anti-Pollen Recirculation Kit	LZ11IXC16	LZ11IXC16	–	–	–
Long Life Regenerative Recirculation Kit	LZ11ITD11	LZ11ITD11	–	–	–

■ Yes, model has this feature. – Feature not available for this model.
¹Power automatically reverts back to normal setting after intensive.
²Air Flow and noise declarations made in line with CECEC Code of Conduct.
³Measured according to EN61591 on largest pipe diameter.
⁴Sound power measured according to EN60704-3 on largest pipe diameter.
⁵From top of pan supports.
⁶A type of recirculating kit is required if recirculating. Depending on the model, a 'Recirculating odour filter kit' will consist of the following items: Charcoal filter, flexible hose, air duct, fixing components, installation instructions.
Data valid in this table as of June 2022. Subject to modification without prior notice.

Intelligent cooling appliances for long lasting freshness

Siemens built-in cooling appliances provide the ultimate way to store food flexibly and correctly for optimum freshness.

From our smallest built-in fridge to our most impressive, each appliance brings you more freshness and convenience. Now you are finally able to combine Siemens cooling appliances exactly the way you want – with the right combinations for every individual requirement, taste and kitchen design. Siemens built-in fridges, freezers and wine coolers come in a wide range of models so that you have full flexibility when planning your kitchen.



Model shown: KI86NHFE0 fridge freezer

Siemens
Cooling

Siemens cooling warranties:

5
Year Warranty

5 Year Warranty
A Siemens five year warranty is available on the Multi Door / American Style fridge freezer and all Siemens freestanding American Style fridge freezers listed in this brochure to protect against manufacturing or material faults and defects during this warranty period.

2
Year Warranty

2 Year Warranty
All other Siemens cooling appliances have a two year manufacturer's warranty as standard to protect against manufacturing or material faults.

Compressor Drive
10
Year Warranty

Compressor Drive 10 Year Warranty
Available on selected Siemens built-in fridges and fridge freezers, this warranty covers defects in the compressor motor.

To find out more about your warranty and for registration, please refer to page 175.

Keep your food fresher for longer



Model shown: hyperFresh premium

hyperFresh technology:

Set the right conditions to ensure your food stays fresher for longer: hyperFresh humidity drawers and near 0°C chiller drawers.

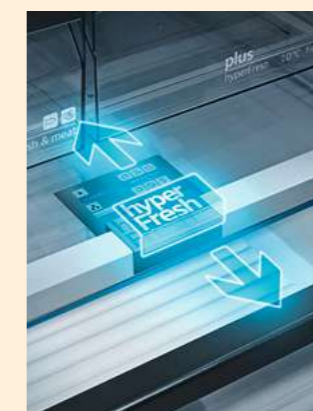
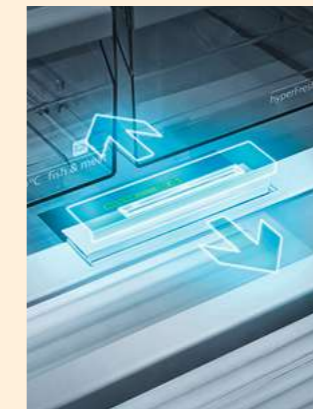

Freshness controlled: hyperFresh
Simply use the stylish control panel to adjust the humidity in the fridge. The hyperFresh drawer with rippled base allows cool air to circulate around your fruits and vegetables easily. As a result, the quality and freshness of your food will be retained.



Shelf life maximised: hyperFresh plus
The hyperFresh plus drawer does not just store food, it provides the right conditions to keep them fresher for longer. Whether you are storing fruits or vegetables, increase shelf life and reduce food wastage. Simply switch between the 2 control settings, and the humidity will be adjusted for optimum storage of your food.



Food stays fresh for longer: hyperFresh premium
Enjoy fresher food with hyperFresh premium. With a choice of 3 humidity controls, simply select whether you are storing fruits, vegetables, or both. The hyperFresh premium drawer will regulate how much humidity your food receives. Be in control; these innovative drawers help to keep in nutrients and minerals to create delicious meals and fewer trips to the supermarkets, saving you time, effort and money. hyperFresh premium is available in selected Siemens single door fridges only.

hyperFresh near 0°C chiller drawers. Perfectly fresh for fish and meat:
The two hyperFresh near 0°C chiller drawers are especially designed for the storage needs of fish and meat. Keep them fresher in ideal conditions near 0°C to retain the vitamins and minerals for longer. With two separate compartments the transfer of unpleasant smells will be avoided.

hyperFresh premium models: These variants come complete with a larger full-length near 0°C chiller drawer, where fish and meat are stored at the perfect temperature.

Create a combination to fit your lifestyle

Our cooling appliances come in a wide range of heights and widths to allow you to create the perfect combination for your kitchen.

177.2 cm
Height

Height and width
Our built-in cooling appliances are available in a range of heights and widths to fit your kitchen design and available space.

Height and width:

All dimensions are shown as Height x Width.

American Style	Fridge Freezers	Single Door Fridges	Single Door Freezers
Model shown: KA93DVIFPG A F	Model shown: KI86NADF0 A E	Model shown: KI81RADE0G A E	Model shown: GI81NHCE0G A E
			
178.6 x 90.8cm 177 x 91cm 175.6 x 91.2cm	177.2 x 55.8cm 177.2 x 54.1cm	177.2 x 59.8cm 177.2 x 54cm 139.7 x 55.8cm 122.1 x 54.1cm 82 x 59.8cm	177.2 x 55.8cm 82 x 59.8cm

Fridge Freezer split options:

60
40
Fridge Freezer split %

Fridge Freezer split
Our range of fridge freezers are available in a variety of sizes with different splits of fridge areas and freezer areas. Alternatively, you can create a bespoke split using separate fridge and freezer units stacked or paired side-by-side.

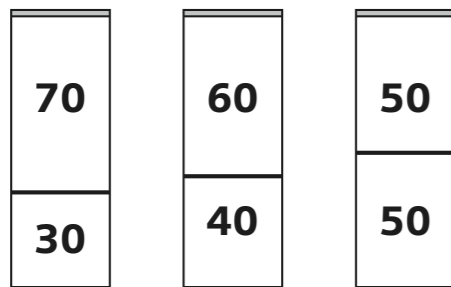

Flexible shelves and door racks.

Expect nothing but convenience with easyLift shelves. Even when full, you can raise or lower the shelf by 6cm to make room for taller items – ideal for serving jugs. Our easyLift door trays are also great for large bottles in the fridge door, the shelf can be adjusted to meet the flexible requirements of your lifestyle.



Flexible modularFit cooling integrated appliances.

Siemens modularFit appliances are freely combinable.

You need a kitchen that matches your lifestyle. That is why our single door cooling and freezing appliances can be combined exactly the way you want – with the right combinations for every individual requirement and taste. But the flexibility does not stop with the way you can arrange your kitchen. With unique and innovative cooling technologies the appliances even enrich your everyday life. Siemens modularFit appliances come with a feeling of flexibility and exciting innovations like hyperFresh and noFrost technology. The simple installation as well as an energy efficiency category offers maximum flexibility and freshness.

Combine your cooling and freezing appliances the way you want: modularFit.

Whether it is on top or next to each other: thanks to the anti-condensation technology you are able to match cooling and freezing appliances however you like. The innovative technology prevents build-up of moisture between the appliances.



Choosing the right hinge: fixed and sliding.

Siemens built-in cooling appliances are available with specific types of hinges that either aid the installation and design of your kitchen or can be matched for replacement appliances.



Fixed hinge
A fixed hinge means that the furniture door is mounted to the appliance door. Advantages of a fixed hinge mean that Siemens can offer softClosing doors that automatically close at an angle of approx 15°-20° preventing the door from accidentally being left open. The installation also offers better access to the appliance interior and due to the optimised width, higher energy efficiency with competitive volume.

They are thoroughly tested to withstand constant opening and closing, the softClose door retracts effortlessly and creates minimal noise. In addition to aesthetics, a softClose door ensures that items within the fridge are not disturbed from a heavy impact, meaning no spills to clean.

Sliding hinge
A sliding hinge means that the furniture door is mounted at the kitchen cabinet body as well as a sliding rail to connect the fridge and furniture door.

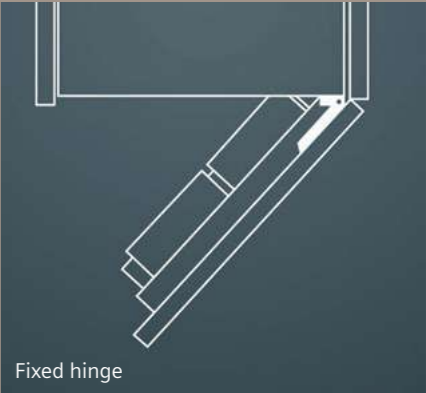

Fixed hinge



Sliding hinge

Explore more cooling features

Experience intelligent cool with Home Connect.

Home Connect fridges

Cooling appliances with Home Connect offer you the ability to flexibly control your appliances using your mobile phone or smart phone. This means you can control your appliance out of home; for example adjusting the fridge temperature to cool down as you are on your way home from a food shop, for extra convenience, and setting your fridge to holiday mode whilst at the airport.

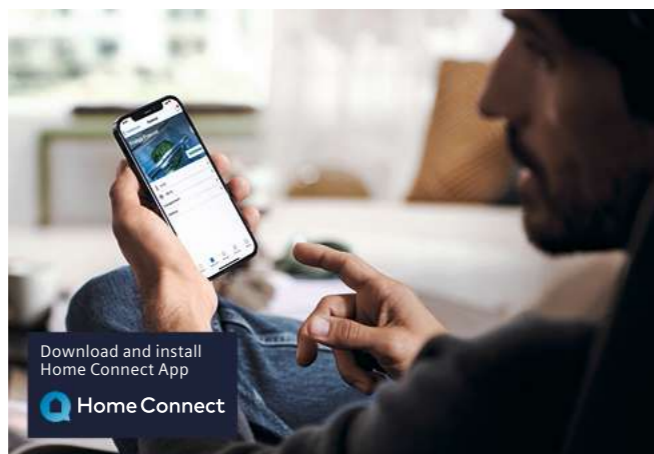

Optimised cooling.

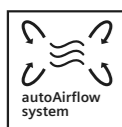

autoAirflow system

This system works with the electronics to optimise the air circulation within the fridge and freezer compartments to ensure even cooling throughout the appliance. This means however you organise your groceries it will cool them quickly no matter where they are placed. The back wall of the appliance has open vents which work with the cooling circuit to draw cold air into each compartment.

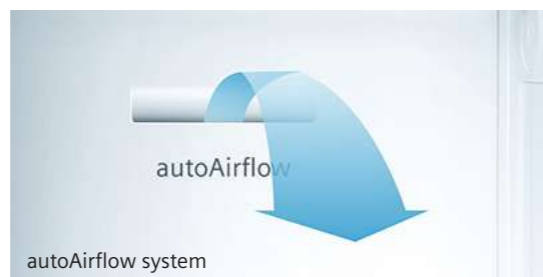

Model shown: K186NADF0 fridge freezer

Type of control.



Interior LCD display

LED Light.



LED light

Type of control.

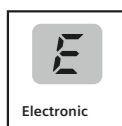

In-door LCD display precision control at the touch of a button. The in-door LCD display allows the optimum temperature for food to be maintained easily, which in turn keeps your food fresher for longer.

LED Light.



The new integrated long-lasting LED lights available on most of our range fit flush in the side walls or ceiling and illuminate the interior uniformly and perfectly without blinding you.

Storage solutions for all of your needs.



Telescopic rails



Bottle rack



freshProtectbox

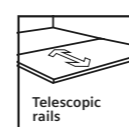

Ergonomically ideal access

Fully-retractable drawers on telescopic rails create an easy access shelving zone. This allows you to easily pull the drawers out further, giving you a better overview of all food items and making them easier to remove.



Bottle rack

Available on some models, the perfect place to store wine of all varieties and make the best use of space in your fridge. The wave-shaped bottle rack can be positioned in a variety of places and safely stores bottles without them rolling back and forth.

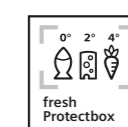

freshProtectbox

Provides the optimum temperature for individual foods, allowing them to stay fresher for longer. Fresh ingredients are critical to delicious meals, but also count for less wastage and fewer trips to the supermarket – saving you, the consumer, time and money.

Freezer features

With noFrost technology you will never have the job of defrosting the freezer again.



noFrost
Defrosting the freezer is now done automatically. Siemens freezers are equipped with intelligent sensor-controlled technology to save the chore of defrosting the freezer. An air-circulation system guides the humidity to the outside of the refrigerator into an external evaporation tray, and sensors measure the degree of humidity and any frost production – ensuring the appliance is periodically defrosted without the need to turn off the appliance or empty it out. Also, ice no longer forms on the inside of the refrigerator, and the appliance's energy consumption remains consistently low.



lowFrost
For those models that come with lowFrost, life is still made easier. lowFrost reduces the build-up of frost by up to 50%, so there is no need to defrost the freezer as often, only once every 3 to 4 years. Designed to save you time and provide added convenience, you can spend your time on the things you enjoy, not defrosting your freezer.

Storage made easy with bigBox.



Big enough for your lifestyle, the bigBox has the capacity for storing whole frozen turkeys, as well as the height to hold dessert glasses upright. Ideal for the holidays and entertaining.



Other useful freezer features.



superFreeze function
superFreeze makes sure that warmer food added to the freezer does not raise the freezer temperature, stopping food partially defrosting.

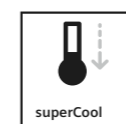

superCool
You can use the superCool button to quickly reduce the temperature in the refrigerator to +2 °C. This prevents an undesirable rise in the temperature of your already chilled food whenever you add food that is not as cold.



Easy to refill for continuous ice: the iceTwister.
Enjoy your own personal ice cube service. Simply activate the iceTwister and receive up to 20 ice cubes at once right away. The water tank is very easy to remove for reliable refilling.



iceDispenser
Models with this feature are able to dispense ice when needed thanks to a plumbed water connection. Depending on model, ice is available as cubes or crushed.



Model shown: GI81NHCE0G freezer



Wine cabinets

Premium design with optimal temperature control.

Your favourite wines deserve to be carefully stored and beautifully presented.

Our wine cabinets will ensure your bottles are displayed effortlessly in a kitchen appliance which makes an impressive visual statement. Thanks to Siemens state-of-the-art technology, your wine will be maintained at the optimal temperature for their type too. So each individual bottle – whether it is red, white or sparkling, is conditioned perfectly for you to enjoy when you need it.

Siemens wine cabinets are designed to provide great first-rate storage for any wine. Wine bottles are presented elegantly on beautifully crafted oak wooden shelves, reducing the risk of scratches or tears to the bottles and labels. Wood is also the perfect surface to display wine, minimising vibrations which can cause wines to age.

Light, especially sunlight, can adversely affect wine. The sun's ultra violet rays in particular can degrade and prematurely age wine. Siemens wine cabinets are equipped with LED lights to minimise heat emitted and, as a result, temperature fluctuations. So the cabinet remains at the optimal temperature at which it is set. Settings can be specified from 5-20°C, allowing you to store your Champagne from 5-8°C, as well as your red wine from 12-20°C.

The glass panelled doors are also protected with a UV filter offering further protection to your bottles from any unnecessary light that can lead them to spoil or fade wine labels.

The soft LED feature provides added drama phasing in gently to reveals your wine. If you plan to make your cabinet the focal point of your kitchen, our Presentation Mode feature will allow you to permanently keep the light on, allowing your bottles to shine in their glory.



Depending on the cabinet you choose, there is space to fit up to 21 bottles in our 30cm wide cabinet, or up to 44 bottles in our 60cm wide unit. The grey interior gives a premium modern seamless finish throughout your kitchen. Each cabinet is also designed with a reversible hinge allowing you to change the direction the door opens depending on how your kitchen units flow.

Acoustic warning light indicators will notify you if the door is opened for a long period, or if the wine storage compartment is too warm or too cold for an extended period so you can be sure your wine is in safe hands.



2 Year Warranty
A Two year warranty is offered on our wine cabinets to cover manufacturing or material faults.

For more information please see page 175.

iQ 500 KU20WVHF0G

Built-under wine cabinet
Black



Model shown: KU20WVHF0G built-under wine cabinet



Built-under wine cabinet specifications

APPLIANCE TYPE	BUILT-UNDER WINE CABINETS	
	iQ 500	iQ 500
Design family	KU20WVHF0G	KU21WAHG0G
Model number	KU20WVHF0G	KU21WAHG0G
Colour	Black	Black
DESIGN FEATURES		
Colour of side panels	Black	Black
Type of glass door	3 glass panels, UV-filtered	3 glass panels, UV-filtered
Door handle type	vertical bar handle	vertical bar handle
Temperature display	Interior / Digital LED	Interior / Digital LED
Reversible door, hinged on right	■	■
Home Connect / Built-in cameras	-	-
KEY FEATURES – WINE CABINET SECTION		
Range of temperature (0°C)	5 - 20	5 - 20
Temperature zones	1	2
LED light	■	■
Number of shelves	4	5
Number of oak shelves	3	3
Number of adjustable shelves	-	-
Presenter shelf and lighting	-	-
Capacity in 0.75L (Bordeaux bottles)	21	44
FUNCTIONS		
Door open warning signal/malfunction	■	■
Child lock	■	■
PERFORMANCE & CONSUMPTION		
Energy efficiency class	A+ F	A+ G
Annual energy consumption ¹ (kWh)	100	130
Refrigerator net capacity (litres)	56	108
Climate Class ²	SN-ST	SN-ST
Noise level (dB [A] re 1pW)	38	38
Noise emission class	C	C
Height of product (mm)	818	818
Width of product (mm)	298	598
Depth of product (mm)	567	581

■ Yes, model has this feature. – Feature not available for this model.

¹ Actual energy consumption will depend on how the appliance is used and where it is located.

² Climate zone SN = designed to operate in ambient temperature of +10°C to 32°C.

Climate zone T = designed to operate in ambient temperature of +18°C to 43°C.

Please note: ventilation grill not supplied.

Data valid in this table as of June 2022. Subject to modification without prior notice.



Model shown: KU21WAHG0G built-under wine cabinet



Make a stylish statement in your kitchen.

Introducing the Multi Door / American Style fridge freezers.

From the premium double-width shelving to the sleek outer finishes – the Multi Door / American Style fridge freezers are designed to stand out in your kitchen. Behind the scenes, our cooling technologies such as multiAirFlow and fresh boxes provide the optimum temperatures to keep all your food and drink at their best while adjustable shelving and smart compartments make it easy to personalise your fridge space and keep your shopping organised. Also with noFrost technology, you will never have to defrost your freezer. With an external width of 91cm, this model is a great option if you are looking to replace or upgrade your standard American Style fridge freezer.

5 Year Warranty

5 Year Warranty

A Five year warranty is offered on all Multi Door / American Style fridge freezer appliances to cover manufacturing or material faults.

For more information please see page 175.



With premium oak shelving compartments and five different set temperatures for soft drinks, beer, champagne, white wine and red wine; the beverage drawer stores your drinks at the ideal temperature, always ready to enjoy.



iQ700 KF96RSBEA

Multi Door / American Style fridge freezer
Black glass door, cast iron sides



Multi Door / American Style fridge freezer specifications

APPLIANCE TYPE	FREESTANDING 90CM
Design family	iQ700
Model number	KF96RSBEA
DESIGN FEATURES	
Colour of door panels	Black glass
Style of handle	Integrated vertical handle
Colour of handle	–
noFrost in fridge and freezer	■
Home Connect, Wi-Fi dongle included	■ / –
FOOD FRESHNESS SYSTEM	
hyperFresh	1 x vegetable drawer
KEY FEATURES – FRIDGE SECTION	
Product highlights	LED
Compressor drive motor	■
superCool function	■
Type of control	Electronic
Number of shelves	5
Number of adjustable shelves	4
Shelves for bottles	–
Number of door bins / shelves	6
Temperature display	Digital LED
Warning signal door open	■
KEY FEATURES – FREEZER SECTION	
Door opened indicator	–
superFreeze function	■
Temperature adjustable in freezer	■
Number of ice cube trays	–
Ice dispenser features	–
Number of freezer drawers	3
ADDITIONAL INFORMATION	
Energy efficiency class	A ↑ E ↓
Energy consumption annual ¹ (kWh)	320
Total net capacity (litres)	572
Refrigerator net capacity (litres)	401
Freezer net capacity (litres)	171
Climate class ²	SN-T
Noise level (dB [A] re 1pW)	39
Noise emission class	C
Additional accessories included	3 x egg trays
Height of product (mm)	1830
Width of product (mm)	910
Depth of product (mm)	710

■ Yes, model has this feature. – Feature not available for this model.

¹ Actual energy consumption will depend on how the appliance is used and where it is located.

² Climate zone SN = designed to operate in ambient temperature of +10°C to 32°C.

Climate zone T = designed to operate in ambient temperature of +18°C to 43°C.

Data valid in this table as of June 2022. Subject to modification without prior notice.



Multi Door / American Style fridge freezer specifications

APPLIANCE TYPE	FREESTANDING 90CM
Design family	IQ700
Model number	KF96NAXEAG
DESIGN FEATURES	
Colour of door panels	Black Inos antiFingerprint
Style of handle	Integrated vertical and horizontal handle
Colour of handle	Black steel
noFrost in fridge and freezer	■
Home Connect, Wi-Fi dongle included	■
FOOD FRESHNESS SYSTEM	
hyperFresh	2 x hyperFresh drawers
KEY FEATURES – FRIDGE SECTION	
Product highlights	LED
Compressor drive motor	■
superCool function	■
Type of control	Electronic
Number of shelves	4
Number of adjustable shelves	3
Shelves for bottles	–
Number of door bins / shelves	5
Temperature display	Digital 7 Segment
Warning signal door open	■
KEY FEATURES – FREEZER SECTION	
Door opened indicator	■
superFreeze function	■
Temperature adjustable in freezer	–
Number of ice cube trays	1
Ice dispenser features	–
Number of freezer drawers	6
ADDITIONAL INFORMATION	
Energy efficiency class	A G E
Energy consumption annual ¹ (kWh)	333
Total net capacity (litres)	605
Refrigerator net capacity (litres)	405
Freezer net capacity (litres)	200
Climate class ²	SN-T
Noise level (dB [A] re 1pW)	38
Noise emission class	C
Additional accessories included	3 x egg trays
Height of product (mm)	1830
Width of product (mm)	910
Depth of product (mm)	731

■ Yes, model has this feature. – Feature not available for this model.

¹ Actual energy consumption will depend on how the appliance is used and where it is located.² Climate zone SN = designed to operate in ambient temperature of +10°C to 32°C.
Climate zone T = designed to operate in ambient temperature of +18°C to 43°C.

Data valid in this table as of June 2022. Subject to modification without prior notice.

Multi Door / American Style fridge freezer specifications

APPLIANCE TYPE	FREESTANDING 90CM
Design family	IQ300
Model number	KF96NVPEAG
DESIGN FEATURES	
Colour of door panels	Inox-easy clean
Style of handle	Integrated vertical and horizontal
Colour of handle	Black
noFrost in fridge and freezer	■
Home Connect, Wi-Fi dongle included	–
FOOD FRESHNESS SYSTEM	
hyperFresh	2 x hyperFresh drawers
KEY FEATURES – FRIDGE SECTION	
Product highlights	LED
Compressor drive motor	■
superCool function	■
Type of control	Electronic
Number of shelves	3
Number of adjustable shelves	2
Shelves for bottles	–
Number of door bins / shelves	5
Temperature display	Digital 7 Segment
Warning signal door open	■
KEY FEATURES – FREEZER SECTION	
Door opened indicator	–
superFreeze function	■
Temperature adjustable in freezer	■
Number of ice cube trays	1
Ice dispenser features	–
Number of freezer drawers	6
ADDITIONAL INFORMATION	
Energy efficiency class	A G E
Energy consumption annual ¹ (kWh)	333
Total net capacity (litres)	605
Refrigerator net capacity (litres)	405
Freezer net capacity (litres)	200
Climate class ²	SN-T
Noise level (dB [A] re 1pW)	38
Noise emission class	C
Additional accessories included	3 x egg trays
Height of product (mm)	1830
Width of product (mm)	910
Depth of product (mm)	731

■ Yes, model has this feature. – Feature not available for this model.

¹ Actual energy consumption will depend on how the appliance is used and where it is located.² Climate zone SN = designed to operate in ambient temperature of +10°C to 32°C.
Climate zone T = designed to operate in ambient temperature of +18°C to 43°C.

Data valid in this table as of June 2022. Subject to modification without prior notice.

Traditional American Style fridge freezers

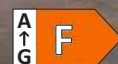

Model shown:
KA93DVIFPG American Style fridge freezer



5 Year Warranty
A Five year warranty is offered on all American Style fridge freezer appliances to cover manufacturing or material faults.

For more information please see page 175.

iQ500 KA93DVIFPG

American Style fridge freezer
Black



Temperature Display: Exterior Digital



American Style fridge freezer specifications

APPLIANCE TYPE	FREESTANDING 90CM
Design family	iQ500
Model number	KA93DVIFPG
DESIGN FEATURES	
Colour of door panels	Stainless steel antiFingerprint
Style of handle	Vertical bar handle
Colour of handle	Stainless steel
noFrost in fridge and freezer	■
Home Connect, Wi-Fi dongle included	-
FOOD FRESHNESS SYSTEM	
hyperFresh	2 x vegetable drawers on rails
KEY FEATURES – FRIDGE SECTION	
Product highlights	LED
Compressor drive motor	■
superCool function	■
Type of control	Electronic
Number of shelves	5
Number of adjustable shelves	-
Shelves for bottles	-
Number of door bins / shelves	5
Temperature display	Digital
Warning signal door open	■
KEY FEATURES – FREEZER SECTION	
Door opened indicator	■
superFreeze function	■
Temperature adjustable in freezer	■
Number of ice cube trays	Automatic ice cube maker
Ice dispenser features	Crushed ice, ice cubes, water, water filter
Number of freezer drawers	2
ADDITIONAL INFORMATION	
Energy efficiency class	A, B, C, D, E, F, G with F highlighted in an orange arrow
Energy consumption annual ¹ (kWh)	404
Total net capacity (litres)	562
Refrigerator net capacity (litres)	371
Freezer net capacity (litres)	191
Climate class ²	SN-T
Noise level (dB [A] re 1pW)	42
Noise emission class	D
Additional accessories included	1 x connection hose, 1 x egg tray
Height of product (mm)	1787
Width of product (mm)	908
Depth of product (mm)	707

■ Yes, model has this feature. - Feature not available for this model.

¹ Actual energy consumption will depend on how the appliance is used and where it is located.

² Climate zone SN = designed to operate in ambient temperature of +10°C to 32°C.

Climate zone T = designed to operate in ambient temperature of +18°C to 43°C.

Data valid in this table as of June 2022. Subject to modification without prior notice.

For specification details, please visit siemens-home.bsh-group.com/uk and download a full specification sheet.

For the full range of accessories, please visit our online accessory shop at siemens-home.bsh-group.com/uk/shop or call our Spares Department on 0344 892 8999.



American Style fridge freezer specifications

APPLIANCE TYPE	FREESTANDING 90CM
Design family	iQ500
Model number	KA931VFFG
DESIGN FEATURES	
Colour of door panels	Stainless steel antiFingerprint
Style of handle	Vertical bar handle
Colour of handle	Stainless steel
noFrost in fridge and freezer	■
Home Connect, Wi-Fi dongle included	-
FOOD FRESHNESS SYSTEM	
hyperFresh	2 x vegetable drawers on rails
KEY FEATURES – FRIDGE SECTION	
Product highlights	LED
Compressor drive motor	■
superCool function	■
Type of control	Electronic
Number of shelves	5
Number of adjustable shelves	-
Shelves for bottles	-
Number of door bins / shelves	5
Temperature display	Digital
Warning signal door open	■
KEY FEATURES – FREEZER SECTION	
Door opened indicator	■
superFreeze function	■
Temperature adjustable in freezer	■
Number of ice cube trays	Automatic ice cube maker
Ice dispenser features	Crushed ice, ice cubes, water
Number of freezer drawers	2
ADDITIONAL INFORMATION	
Energy efficiency class	
Energy consumption annual ¹ (kWh)	404
Total net capacity (litres)	562
Refrigerator net capacity (litres)	371
Freezer net capacity (litres)	191
Climate class ²	SN-T
Noise level (dB [A] re 1pW)	42
Noise emission class	D
Additional accessories included	1 x egg tray
Height of product (mm)	1787
Width of product (mm)	908
Depth of product (mm)	707

■ Yes, model has this feature. - Feature not available for this model.

¹ Actual energy consumption will depend on how the appliance is used and where it is located.

² Climate zone SN = designed to operate in ambient temperature of +10°C to 32°C.

Climate zone T = designed to operate in ambient temperature of +18°C to 43°C.

Data valid in this table as of June 2022. Subject to modification without prior notice.

American Style fridge freezer specifications

APPLIANCE TYPE	FREESTANDING 90CM
Design family	iQ300
Model number	KA93NVFFP
DESIGN FEATURES	
Colour of door panels	Stainless steel antiFingerprint
Style of handle	Vertical bar handle
Colour of handle	Stainless steel
noFrost in fridge and freezer	■
Home Connect, Wi-Fi dongle included	-
FOOD FRESHNESS SYSTEM	
hyperFresh	2 x vegetable drawers on rails
KEY FEATURES – FRIDGE SECTION	
Product highlights	LED
Compressor drive motor	■
superCool function	■
Type of control	Electronic
Number of shelves	5
Number of adjustable shelves	-
Shelves for bottles	-
Number of door bins / shelves	5
Temperature display	Digital
Warning signal door open	■
KEY FEATURES – FREEZER SECTION	
Door opened indicator	■
superFreeze function	■
Temperature adjustable in freezer	■
Number of ice cube trays	Twist ice box
Ice dispenser features	-
Number of freezer drawers	2
ADDITIONAL INFORMATION	
Energy efficiency class	
Energy consumption annual ¹ (kWh)	413
Total net capacity (litres)	580
Refrigerator net capacity (litres)	372
Freezer net capacity (litres)	208
Climate class ²	SN-T
Noise level (dB [A] re 1pW)	42
Noise emission class	D
Additional accessories included	1 x egg tray
Height of product (mm)	1787
Width of product (mm)	908
Depth of product (mm)	707

■ Yes, model has this feature. - Feature not available for this model.

¹ Actual energy consumption will depend on how the appliance is used and where it is located.

² Climate zone SN = designed to operate in ambient temperature of +10°C to 32°C.

Climate zone T = designed to operate in ambient temperature of +18°C to 43°C.

Data valid in this table as of June 2022. Subject to modification without prior notice.

Fridge freezers

NoFrost

iQ 500 K186NADF0

noFrost bottom fridge freezer
177cm high

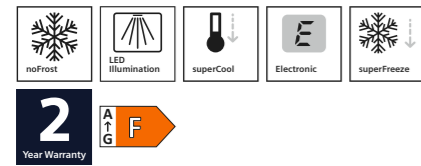

Fridge freezer specifications

APPLIANCE TYPE	NOFROST BOTTOM FRIDGE FREEZER
Design family	iQ 500
Model number	K186NADF0
DESIGN FEATURES	
Fridge / Freezer split	60 / 40
noFrost	■
lowFrost	-
softClose hinge	■
Type of hinge (reversible)	Fixed hinge
Home Connect	-
FOOD FRESHNESS SYSTEM	
hyperFresh	1 hyperFresh Plus box
KEY FEATURES – FRIDGE SECTION	
Compressor drive motor	■
Light	LED
superCool function	■
Type of control	Electronic
Number of shelves	5
Number of adjustable shelves	4
Number of door bins / shelves	5
Type of shelves	Safety glass
Temperature display	Digital 7 segment
Warning signal door open	■
Bottle shelves in fridge	-
KEY FEATURES – FREEZER SECTION	
Door opened indicator	-
superFreeze function	■
Temperature adjustable in freezer	■
Number of ice cube trays	1
Number of freezer drawers	3
ADDITIONAL INFORMATION	
Energy efficiency class	A++ F
Energy consumption annual ¹ (kWh)	277
Total net capacity (litres)	254
Refrigerator net capacity 4°C-8°C (litres)	187
Refrigerator net capacity 0°C (litres)	-
Freezer net capacity litres	67
Climate class ²	SN-ST
Noise level (dB [A] re 1pW)	39
Noise emission class	C
Additional accessories included	2 x egg trays, 1 x ice cube tray, 1 x bottle holder in door tray
Height of product (mm)	1772
Width of product (mm)	558
Depth of product (mm)	545

■ Yes, model has this feature. - Feature not available for this model.

¹ Actual energy consumption will depend on how the appliance is used and where it is located.

² Climate zone SN = designed to operate in ambient temperature of +10°C to 32°C.

Climate zone T = designed to operate in ambient temperature of +18°C to 43°C.

Data valid in this table as of June 2022. Subject to modification without prior notice.

Home Connect



Fridge freezer specifications

APPLIANCE TYPE	NOFROST BOTTOM FRIDGE FREEZERS		
Design family	iQ 300	iQ 300	iQ 300
Model number	K186NHFE0	K186NVFE0G	K186NVSE0G
DESIGN FEATURES			
Fridge / Freezer split	60 / 40	60 / 40	60 / 40
noFrost	■	■	■
lowFrost	-	-	-
softClose hinge	-	-	-
Type of hinge (reversible)	Fixed hinge	Fixed hinge	Sliding hinge
Home Connect	■	-	-
FOOD FRESHNESS SYSTEM			
hyperFresh	2 x hyperFresh drawers	2 x hyperFresh drawers	2 x hyperFresh drawers
KEY FEATURES – FRIDGE SECTION			
Compressor drive motor	■	■	■
Light	LED	LED	LED
superCool function	■	-	-
Type of control	Electronic	Electronic	Electronic
Number of shelves	5	3	3
Number of adjustable shelves	3	3	3
Number of door bins / shelves	3	3	3
Type of shelves	Safety glass	Safety glass	Safety glass
Temperature display	Digital LED	Digital LED	Digital LED
Warning signal door open	■	■	■
Bottle shelves in fridge	■	■	■
KEY FEATURES – FREEZER SECTION			
Door opened indicator	■	■	■
superFreeze function	■	■	■
Temperature adjustable in freezer	-	-	-
Number of ice cube trays	1	1	1
Number of freezer drawers	3	3	3
ADDITIONAL INFORMATION			
Energy efficiency class	A++ E	A++ E	A++ E
Energy consumption annual ¹ (kWh)	234	234	260
Total net capacity (litres)	260	260	184
Refrigerator net capacity 4°C-8°C (litres)	184	184	76
Refrigerator net capacity 0°C (litres)	24	24	24
Freezer net capacity litres	76	76	7
Climate class ²	SN-ST	SN-ST	SN-ST
Noise level (dB [A] re 1pW)	35	35	39
Noise emission class	B	B	B
Additional accessories included	3 x egg trays, 1 x ice cube tray	3 x egg trays, 1 x ice cube tray	3 x egg trays, 1 x ice cube tray
Height of product (mm)	1772	1772	1772
Width of product (mm)	541	541	541
Depth of product (mm)	548	548	548

■ Yes, model has this feature. - Feature not available for this model.

¹ Actual energy consumption will depend on how the appliance is used and where it is located.

² Climate zone SN = designed to operate in ambient temperature of +10°C to 32°C.

Climate zone T = designed to operate in ambient temperature of +18°C to 43°C.

Data valid in this table as of June 2022. Subject to modification without prior notice.

Fridge freezers

LowFrost



Fridge freezer specifications

APPLIANCE TYPE	NOFROST BOTTOM FRIDGE FREEZERS		
Design family	iQ100	iQ100	iQ100
Model number	KI86NNFF0	KI86NNSF0	KI85NFF0G
DESIGN FEATURES			
Fridge / Freezer split	70 / 30	70 / 30	50 / 50
noFrost	■	■	■
lowFrost	-	-	-
softClose hinge	-	-	-
Type of hinge (reversible)	Fixed hinge	Fixed hinge	Fixed hinge
Home Connect	-	-	-
FOOD FRESHNESS SYSTEM			
hyperFresh	1 x vegetable drawer	1 x vegetable drawer	1 x vegetable drawer
KEY FEATURES – FRIDGE SECTION			
Compressor drive motor	■	■	■
Light	LED	LED	LED
superCool function	-	-	-
Type of control	Electronic	Electronic	Electronic
Number of shelves	4	4	3
Number of adjustable shelves	3	3	2
Number of door bins / shelves	3	3	2
Type of shelves	Safety glass	Safety glass	Safety glass
Temperature display	Digital LED	Digital LED	Digital display
Warning signal door open	■	■	■
Bottle shelves in fridge	-	-	-
KEY FEATURES – FREEZER SECTION			
Door opened indicator	■	■	■
superFreeze function	■	■	■
Temperature adjustable in freezer	■	■	-
Number of ice cube trays	1	1	1
Number of freezer drawers	3	3	4
ADDITIONAL INFORMATION			
Energy efficiency class			
Energy consumption annual ¹ (kWh)	293	293	298
Total net capacity (litres)	260	260	249
Refrigerator net capacity 4°C-8°C (litres)	184	184	150
Refrigerator net capacity 0°C (litres)	-	-	-
Freezer net capacity litres	76	76	99
Climate class ²	SN-ST	SN-ST	SN-ST
Noise level (dB [A] re 1pW)	39	39	39
Noise emission class	C	C	C
Additional accessories included	3 x egg trays, 1 x ice cube tray	3 x egg trays, 1 x ice cube tray	3 x egg trays, 1 x ice cube tray
Height of product (mm)	1772	1772	1772
Width of product (mm)	541	541	541
Depth of product (mm)	548	548	548

■ Yes, model has this feature. – Feature not available for this model.

¹ Actual energy consumption will depend on how the appliance is used and where it is located.

² Climate zone SN = designed to operate in ambient temperature of +10°C to 32°C.
Climate zone T = designed to operate in ambient temperature of +18°C to 43°C.

Data valid in this table as of June 2022. Subject to modification without prior notice.



iQ500 KI87SAFE0G

noFrost bottom fridge freezer
177cm high

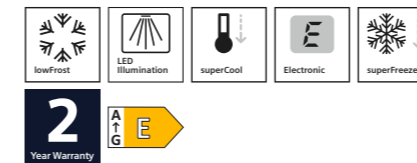

Fridge freezer specifications

APPLIANCE TYPE	LOWFROST BOTTOM FRIDGE FREEZER
Design family	iQ500
Model number	KI87SAFE0G
DESIGN FEATURES	
Fridge / Freezer split	70 / 30
noFrost	-
lowFrost	lowFrost
softClose hinge	-
Type of hinge (reversible)	Fixed hinge
Home Connect	-
FOOD FRESHNESS SYSTEM	
hyperFresh	1 hyperFresh Plus drawer
KEY FEATURES – FRIDGE SECTION	
Compressor drive motor	■
Light	LED
superCool function	■
Type of control	Electronic
Number of shelves	5
Number of adjustable shelves	4
Number of door bins / shelves	5
Type of shelves	Safety glass
Temperature display	Digital 7 segment
Warning signal door open	■
Bottle shelves in fridge	-
KEY FEATURES – FREEZER SECTION	
Door opened indicator	■
superFreeze function	■
Temperature adjustable in freezer	■
Number of ice cube trays	2
Number of freezer drawers	2
ADDITIONAL INFORMATION	
Energy efficiency class	
Energy consumption annual ¹ (kWh)	207
Total net capacity (litres)	272
Refrigerator net capacity 4°C-8°C (litres)	209
Refrigerator net capacity 0°C (litres)	-
Freezer net capacity litres	63
Climate class ²	SN-T
Noise level (dB [A] re 1pW)	36
Noise emission class	C
Additional accessories included	2 x ice packs, 3 x egg trays, 1 x ice cube tray 1 x ice cube tray with lid, 1 x bottle holder in door tray
Height of product (mm)	1772
Width of product (mm)	558
Depth of product (mm)	545

■ Yes, model has this feature. – Feature not available for this model.

¹ Actual energy consumption will depend on how the appliance is used and where it is located.

² Climate zone SN = designed to operate in ambient temperature of +10°C to 32°C.
Climate zone T = designed to operate in ambient temperature of +18°C to 43°C.

Data valid in this table as of June 2022. Subject to modification without prior notice.

Fridge freezers

LowFrost



Fridge freezer specifications

APPLIANCE TYPE	LOWFROST BOTTOM FRIDGE FREEZERS		
Design family	IQ500	IQ300	IQ300
Model number	KI86SAFE0G	KI86VVE0G	KI87VFE0G
DESIGN FEATURES			
Fridge / Freezer split	60 / 40	60/40	70/30
noFrost	-	-	-
lowFrost	lowFrost	lowFrost	lowFrost
softClose hinge	-	-	-
Type of hinge (reversible)	Fixed hinge	Fixed hinge	Fixed hinge
Home Connect	-	-	-
FOOD FRESHNESS SYSTEM			
hyperFresh	1 hyperFresh Plus drawer	1 vegetable drawer	1 vegetable drawer
KEY FEATURES – FRIDGE SECTION			
Compressor drive motor	■	■	■
Light	LED	LED	LED
superCool function	■	-	-
Type of control	Electronic	Electronic	Electronic
Number of shelves	5	4	5
Number of adjustable shelves	4	3	4
Number of door bins / shelves	5	3	4
Type of shelves	Safety glass	Safety glass	Safety glass
Temperature display	Digital 7 segment	Digital LED	Digital LED
Warning signal door open	■	■	■
Bottle shelves in fridge	-	■	■
KEY FEATURES – FREEZER SECTION			
Door opened indicator	■	■	■
superFreeze function	■	■	■
Temperature adjustable in freezer	■	-	-
Number of ice cube trays	2	2	2
Number of freezer drawers	3	3	2
ADDITIONAL INFORMATION			
Energy efficiency class			
Energy consumption annual ¹ (kWh)	219	229	216
Total net capacity (litres)	266	267	270
Refrigerator net capacity 4°C-8°C (litres)	192	183	200
Refrigerator net capacity 0°C (litres)	-	-	-
Freezer net capacity litres	74	84	70
Climate class ²	SN-ST	SN-T	SN-T
Noise level (dB [A] re 1pW)	36	35	35
Noise emission class	C	D	D
Additional accessories included	2 x ice packs, 3 x egg trays, 1 x ice cube tray 1 x ice cube tray with lid, 1 x bottle holder in door tray	2 x ice packs, 3 x egg trays, 1 x ice cube tray, 1 x ice cube tray with lid	2 x ice packs, 3 x egg trays, 1 x ice cube tray, 1 x ice cube tray with lid
Height of product (mm)	1772	1772	1772
Width of product (mm)	558	541	541
Depth of product (mm)	545	545	545

■ Yes, model has this feature. – Feature not available for this model.

¹ Actual energy consumption will depend on how the appliance is used and where it is located.

² Climate zone SN = designed to operate in ambient temperature of +10°C to 32°C.
Climate zone T = designed to operate in ambient temperature of +18°C to 43°C.

Data valid in this table as of June 2022. Subject to modification without prior notice.



Fridge freezer specifications

APPLIANCE TYPE	LOWFROST BOTTOM FRIDGE FREEZERS	
Design family	IQ300	IQ100
Model number	KI87VNSE0G	KI87VNSFOG
DESIGN FEATURES		
Fridge / Freezer split	70/30	70/30
noFrost	-	-
lowFrost	lowFrost	lowFrost
softClose hinge	-	-
Type of hinge (reversible)	Sliding hinge	Sliding hinge
Home Connect	-	-
FOOD FRESHNESS SYSTEM		
hyperFresh	1 vegetable drawer	1 vegetable drawer
KEY FEATURES – FRIDGE SECTION		
Compressor drive motor	■	■
Light	LED	LED
superCool function	-	-
Type of control	Electronic	Electronic
Number of shelves	5	5
Number of adjustable shelves	4	4
Number of door bins / shelves	5	4
Type of shelves	Safety glass	Safety glass
Temperature display	Digital LED	Digital LED
Warning signal door open	■	-
Bottle shelves in fridge	■	-
KEY FEATURES – FREEZER SECTION		
Door opened indicator	■	-
superFreeze function	■	■
Temperature adjustable in freezer	-	-
Number of ice cube trays	2	1
Number of freezer drawers	2	2
ADDITIONAL INFORMATION		
Energy efficiency class		
Energy consumption annual ¹ (kWh)	216	270
Total net capacity (litres)	270	270
Refrigerator net capacity 4°C - 8°C (litres)	200	200
Refrigerator net capacity 0°C (litres)	-	-
Freezer net capacity litres	70	70
Climate class ²	SN-T	SN-ST
Noise level (dB [A] re 1pW)	35	39
Noise emission class	D	C
Additional accessories included	2 x ice packs, 3 x egg trays, 1 x ice cube tray, 1 x ice cube tray with lid	3 x egg trays, 1 x ice cube tray
Height of product (mm)	1772	1772
Width of product (mm)	541	541
Depth of product (mm)	545	545

■ Yes, model has this feature. – Feature not available for this model.

¹ Actual energy consumption will depend on how the appliance is used and where it is located.

² Climate zone SN = designed to operate in ambient temperature of +10°C to 32°C.
Climate zone T = designed to operate in ambient temperature of +18°C to 43°C.

Data valid in this table as of June 2022. Subject to modification without prior notice.

Single door fridges and freezers

iQ500 KI81RADE0G

Single door fridge
177cm high



Single door fridges and freezer specifications

APPLIANCE TYPE		FRIDGE 177CM
Design family		iQ500
Model number		KI81RADE0G
DESIGN FEATURES		
Fridge / Freezer split		-
noFrost		-
lowFrost or Manual defrost		-
softClose hinge		■
Type of hinge (reversible)		Fixed hinge
Home Connect		-
FOOD FRESHNESS SYSTEM		
hyperFresh		1 hyperFresh Plus vegetable drawer with telescopic rails, 1 vegetable drawer with telescopic rails
KEY FEATURES – FRIDGE SECTION		
Compressor drive motor		-
Light		LED
superCool function		■
Type of control		Electronic
Number of shelves		7
Number of adjustable shelves		6
Number of door bins / shelves		7
Type of shelves		Safety glass
Temperature display		Digital x 7 segment
Warning signal door open		■
Defrost system in fridge		Automatic
Bottle shelves in fridge		1 bottle support grid
KEY FEATURES – FREEZER SECTION		
Light in freezer		-
Warning signal door open		-
superFreeze function		-
Temperature adjustable in freezer		-
Number of ice cube trays		-
Number of freezing flaps		-
Number of freezer drawers		-
ADDITIONAL INFORMATION		
Energy efficiency class		A G E
Energy consumption annual ¹ (kWh)		115
Total net capacity including near 0°C drawers (litres)		319
Refrigerator net capacity 0°C (litres)		319
Freezer net capacity (litres)		-
Climate class ²		SN-T
Noise level (dB [A] re 1pW)		37
Noise emission class		C
Additional accessories included		3 x egg trays
Height of product (mm)		1772
Width of product (mm)		558
Depth of product (mm)		545

■ Yes, model has this feature. – Feature not available for this model.

¹ Actual energy consumption will depend on how the appliance is used and where it is located.

² Climate zone SN = designed to operate in ambient temperature of +10°C to 32°C.

Climate zone T = designed to operate in ambient temperature of +18°C to 43°C.

Data valid in this table as of June 2022. Subject to modification without prior notice.



Single door fridges and freezer specifications

APPLIANCE TYPE		FRIDGES 177CM		
Design family		iQ500	iQ500	iQ300
Model number		KI81RAFE0G	KI82LAFF0	KI81RV5F0G
DESIGN FEATURES				
Fridge / Freezer split		-	-	-
noFrost		-	-	-
lowFrost or Manual defrost		-	-	-
softClose hinge		-	-	-
Type of hinge (reversible)		Fixed hinge	Fixed hinge	Sliding hinge
Home Connect		-	-	-
FOOD FRESHNESS SYSTEM				
hyperFresh		1 hyperFresh Plus vegetable drawer with telescopic rails, 1 vegetable drawer with telescopic rails	1 hyperFresh Plus vegetable drawer with telescopic rails, 1 vegetable drawer with telescopic rails	2 vegetable drawers
KEY FEATURES – FRIDGE SECTION				
Compressor drive motor		-	-	-
Light		LED	LED	LED
superCool function		■	■	■
Type of control		Electronic	Electronic	Electronic
Number of shelves		7	5	7
Number of adjustable shelves		6	4	6
Number of door bins / shelves		7	5	6
Type of shelves		Safety glass	Safety glass	Safety glass
Temperature display		Digital x 7 segment	Digital x 7 segment	1 x LED chain
Warning signal door open		■	■	-
Defrost system in fridge		Automatic	Automatic	Automatic
Bottle shelves in fridge		1 bottle support grid	-	-
KEY FEATURES – FREEZER SECTION				
Light in freezer		-	-	-
Warning signal door open		-	■	-
superFreeze function		-	-	-
Temperature adjustable in freezer		-	-	-
Number of ice cube trays		-	1	-
Number of freezing flaps		-	1	-
Number of freezer drawers		-	-	-
ADDITIONAL INFORMATION				
Energy efficiency class		A G E	A G F	A G F
Energy consumption annual ¹ (kWh)		115	222	144
Total net capacity including near 0°C drawers (litres)		319	286	319
Refrigerator net capacity 0°C (litres)		319	252	319
Freezer net capacity (litres)		-	34	-
Climate class ²		SN-T	SN-ST	SN-T
Noise level (dB [A] re 1pW)		37	36	37
Noise emission class		C	C	C
Additional accessories included		2 x egg trays	2 x egg trays, 1 x ice cube tray	2 x egg trays
Height of product (mm)		1772	1772	1772
Width of product (mm)		558	558	541
Depth of product (mm)		545	545	545

■ Yes, model has this feature. – Feature not available for this model.

¹ Actual energy consumption will depend on how the appliance is used and where it is located.

² Climate zone SN = designed to operate in ambient temperature of +10°C to 32°C.

Climate zone T = designed to operate in ambient temperature of +18°C to 43°C.

Data valid in this table as of June 2022. Subject to modification without prior notice.

iQ 700 GI81NHCE0G

Single door freezer
177cm high



Single door fridges and freezer specifications

APPLIANCE TYPE	FREEZER 177CM
Design family	iQ 700
Model number	GI81NHCE0G
DESIGN FEATURES	
Fridge / Freezer split	-
noFrost	■
lowFrost or Manual defrost	-
softClose hinge	■
Type of hinge (reversible)	Fixed hinge
Home Connect	■
FOOD FRESHNESS SYSTEM	
hyperFresh	-
KEY FEATURES – FRIDGE SECTION	
Compressor drive motor	-
Light	-
superCool function	-
Type of control	-
Number of shelves	-
Number of adjustable shelves	-
Number of door bins / shelves	-
Type of shelves	-
Temperature display	-
Warning signal door open	-
Defrost system in fridge	-
Bottle shelves in fridge	-
KEY FEATURES – FREEZER SECTION	
Light in freezer	-
Warning signal door open	■
superFreeze function	■
Temperature adjustable in freezer	■
Number of ice cube trays	2
Number of freezing flaps	2
Number of freezer drawers	5
ADDITIONAL INFORMATION	
Energy efficiency class	A+G
Energy consumption annual ¹ (kWh)	235
Total net capacity including near 0° drawers (litres)	212
Refrigerator net capacity 0°C (litres)	-
Freezer net capacity (litres)	212
Climate class ²	SN-T
Noise level (dB [A] re 1pW)	35
Noise emission class	B
Additional accessories included	1 x ice cube tray
Height of product (mm)	1772
Width of product (mm)	558
Depth of product (mm)	545

■ Yes, model has this feature. – Feature not available for this model.

¹ Actual energy consumption will depend on how the appliance is used and where it is located.

² Climate zone SN = designed to operate in ambient temperature of +10°C to 32°C.
Climate zone T = designed to operate in ambient temperature of +18°C to 43°C.

Data valid in this table as of June 2022. Subject to modification without prior notice.

Single door fridges and freezer specifications



APPLIANCE TYPE	FREEZER 177CM	FRIDGE 140CM	FRIDGE 122CM
Design family	iQ 500	iQ 500	iQ 500
Model number	GI81NAEFOG	KI51RADFO	KI41RAFFO
DESIGN FEATURES			
Fridge / Freezer split	-	-	-
noFrost	■	-	-
lowFrost or Manual defrost	-	-	-
softClose hinge	-	■	■
Type of hinge (reversible)	Fixed hinge	Fixed hinge	Fixed hinge
Home Connect	-	-	-
FOOD FRESHNESS SYSTEM			
hyperFresh	-	1 hyperFresh Plus vegetable drawer	1 hyperFresh Plus vegetable drawer
KEY FEATURES – FRIDGE SECTION			
Compressor drive motor	-	-	-
Light	-	LED	LED
superCool function	-	■	■
Type of control	-	Electronic	Electronic
Number of shelves	-	6	6
Number of adjustable shelves	-	5	5
Number of door bins / shelves	-	5	4
Type of shelves	-	Safety glass	Safety glass
Temperature display	-	Digital x 7 segment	Digital x 7 segment
Warning signal door open	-	■	■
Defrost system in fridge	-	Automatic	Automatic
Bottle shelves in fridge	-	-	-
KEY FEATURES – FREEZER SECTION			
Light in freezer	-	-	-
Warning signal door open	■	-	-
superFreeze function	■	-	-
Temperature adjustable in freezer	■	-	-
Number of ice cube trays	1	-	-
Number of freezing flaps	2	-	-
Number of freezer drawers	5	-	-
ADDITIONAL INFORMATION			
Energy efficiency class	A+G	A+G	A+G
Energy consumption annual ¹ (kWh)	294	133	123
Total net capacity including near 0°C drawers (litres)	212	247	211
Refrigerator net capacity 0°C (litres)	-	247	211
Freezer net capacity (litres)	212	-	-
Climate class ²	SN-T	SN-T	SN-T
Noise level (dB [A] re 1pW)	36	33	33
Noise emission class	C	B	B
Additional accessories included	1 x ice cube tray	3 x egg trays	2 x egg trays
Height of product (mm)	1772	1397	1221
Width of product (mm)	558	558	558
Depth of product (mm)	545	545	545

■ Yes, model has this feature. – Feature not available for this model.

¹ Actual energy consumption will depend on how the appliance is used and where it is located.

² Climate zone SN = designed to operate in ambient temperature of +10°C to 32°C.
Climate zone T = designed to operate in ambient temperature of +18°C to 43°C.

Data valid in this table as of June 2022. Subject to modification without prior notice.

Single door fridges and freezer specifications



APPLIANCE TYPE	FRIDGE 87CM	FREEZER 87CM	FREEZER 72CM
Design family	IQ500	IQ500	IQ500
Model number	KI21RAFF0	GI21VAFE0	GI11VAFE0
DESIGN FEATURES			
Fridge / Freezer split	-	-	-
noFrost	-	-	-
lowFrost or Manual defrost	-	lowFrost	lowFrost
softClose hinge	-	-	-
Type of hinge (reversible)	Fixed hinge	Fixed hinge	Fixed hinge
Home Connect	-	-	-
FOOD FRESHNESS SYSTEM			
hyperFresh	1 hyperFresh vegetable drawer	-	-
KEY FEATURES – FRIDGE SECTION			
Compressor drive motor	-	-	-
Light	LED	-	-
superCool function	■	-	-
Type of control	Electronic	-	-
Number of shelves	4	-	-
Number of adjustable shelves	3	-	-
Number of door bins / shelves	3	-	-
Type of shelves	Safety glass	-	-
Temperature display	Digital x 7 segment	-	-
Warning signal door open	■	-	-
Defrost system in fridge	■	-	-
Bottle shelves in fridge	-	-	-
KEY FEATURES – FREEZER SECTION			
Light in freezer	-	-	-
Warning signal door open	-	■	■
superFreeze function	-	■	■
Temperature adjustable in freezer	-	■	■
Number of ice cube trays	-	1	1
Number of freezing flaps	-	-	-
Number of freezer drawers	-	3	3
ADDITIONAL INFORMATION			
Energy efficiency class	A F	A E	A E
Energy consumption annual ¹ (kWh)	117	176	167
Total net capacity including near 0°C drawers (litres)	144	96	72
Refrigerator net capacity 0°C (litres)	144	-	-
Freezer net capacity (litres)	-	96	72
Climate class ²	SN-T	SN-T	SN-T
Noise level (dB [A] re 1pW)	33	36	36
Noise emission class	B	C	C
Additional accessories included	2 x egg trays	1 x ice cube tray	1 x ice cube tray
Height of product (mm)	874	874	712
Width of product (mm)	558	558	558
Depth of product (mm)	545	545	545

■ Yes, model has this feature. – Feature not available for this model.

¹ Actual energy consumption will depend on how the appliance is used and where it is located.

² Climate zone SN = designed to operate in ambient temperature of +10°C to 32°C.

Climate zone T = designed to operate in ambient temperature of +18°C to 43°C.

Data valid in this table as of June 2022. Subject to modification without prior notice.

Single door fridges and freezer specifications



APPLIANCE TYPE	BUILT-UNDER FRIDGE WITH ICE BOX 82CM	BUILT-UNDER FRIDGE 82CM	BUILT-UNDER FREEZER 82CM
Design family	IQ500	IQ500	IQ500
Model number	KU15LAFF0G	KU15RAFF0G	GU15DAFF0G
DESIGN FEATURES			
Fridge / Freezer split	-	-	-
noFrost	-	-	-
lowFrost or Manual defrost	-	-	■
softClose hinge	-	-	-
Type of hinge (reversible)	Fixed hinge	Fixed hinge	Fixed hinge
Home Connect	-	-	-
FOOD FRESHNESS SYSTEM			
hyperFresh	2 vegetable drawers	2 vegetable drawers	-
KEY FEATURES – FRIDGE SECTION			
Compressor drive motor	-	-	-
Light	1 x 25 watt	1 x 25 watt	-
superCool function	-	-	-
Type of control	none (mechanical)	none (mechanical)	-
Number of shelves	2	3	-
Number of adjustable shelves	1	3	-
Number of door bins / shelves	3	3	-
Type of shelves	Safety glass	Safety glass	-
Temperature display	-	-	-
Warning signal door open	-	-	-
Defrost system in fridge	Automatic	Automatic	-
Bottle shelves in fridge	-	-	-
KEY FEATURES – FREEZER SECTION			
Light in freezer	-	-	-
Warning signal door open	-	-	■
superFreeze function	-	-	■
Temperature adjustable in freezer	-	-	Dial temperature control
Number of ice cube trays	1	-	1
Number of freezing flaps	-	-	-
Number of freezer drawers	1 x flap to freezer	-	3
ADDITIONAL INFORMATION			
Energy efficiency class	A F	A F	A F
Energy consumption annual ¹ (kWh)	180	114	224
Total net capacity including near 0°C drawers (litres)	123	137	106
Refrigerator net capacity 0°C (litres)	-	137	-
Freezer net capacity (litres)	15	-	106
Climate class ²	SN-ST	SN-ST	SN-ST
Noise level (dB [A] re 1pW)	38	38	38
Noise emission class	C	C	C
Additional accessories included	1 x egg tray, 1 x ice cube tray	1 x egg tray	1 x ice cube tray
Height of product (mm)	820	820	820
Width of product (mm)	598	598	598
Depth of product (mm)	548	548	548

■ Yes, model has this feature. – Feature not available for this model.

¹ Actual energy consumption will depend on how the appliance is used and where it is located.

² Climate zone SN = designed to operate in ambient temperature of +10°C to 32°C.

Climate zone T = designed to operate in ambient temperature of +18°C to 43°C.

Data valid in this table as of June 2022. Subject to modification without prior notice.

Dishwashers. Innovative features for sparkling results

Siemens dishwashers feature modern design and innovative ideas for seamless living.

Experience maximum flexibility with practical innovations such as varioSpeed Plus which reduces a programme's speed by 30%-to 70% and Zeolith® drying technology that transforms humidity into heat for gentle and effective drying results.

Our dishwashers include height-adjustable baskets and foldable racks, stylish innovations such as door openAssist, sideLight and timeLight floor projection, all working together to provide you with the perfect balance between modern design and innovative technology. Whether you are serving dinner for family or hosting a party for friends, Siemens dishwashers ensure that you will have sparkling clean dishes and glasses quickly.



Model shown: **SN87YX03CE**
fully integrated dishwasher

Dishwashers

Siemens dishwasher warranties:



2 Year Warranty
A Two Year Warranty is available on all Siemens dishwashers listed in this brochure to protect against manufacturing and materials faults during this warranty period.



10 Year Anti-Rust Warranty
All Siemens dishwashers purchased from the 1st January 2012 onwards have a 10 Year Anti-Rust Warranty to protect against rust in the inner cavity of the appliance.

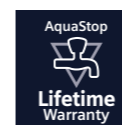

Lifetime AquaStop Warranty
All Siemens dishwashers listed in this brochure have a lifetime AquaStop warranty to protect against water damage caused by a defective AquaStop system.

To find out more about your warranty and for registration, please refer to page 175.

Your daily forecast

dry conditions,
brilliant views

Welcome to a new era of dishwashing with brilliantShine.



Our new 60cm dishwashers feature the brilliantShine programme – a one touch solution that combines the Glass 40°C programme and the Shine & Dry option to ensure your glassware is always left sparkling clean.

Straight from dishwasher to table, Shine & Dry gives you streak-free, shining glasses. Harnessing the power of Zeolith® at its best, the special drying cycle also works just as well on plastics, pots and pans, saving you time as you no longer need to give them an extra towel dry. The brilliantShine programme with Zeolith® Drying creates sparkling glasses that you can be proud of, keeping your glassware ready to shine for your guests, even unexpected ones.

There are three factors in dishwashing that influence the shine of your glassware: temperature, cycle time, and the use of detergent. The new brilliantShine programme offers three intelligent solutions that take care of these factors:

- Zeolith® drying uses a Zeolite mineral that absorbs moisture and converts it into a gentle heat.
- The Shine & Dry option swills all residues of detergent with extra rinsing water, resulting in streak-free, shining glassware.
- The Glass 40°C programme ensures that your glassware is not exposed to excessive temperatures or spray pressures, and keeps the cycle time shorter.

Zeolith®: Super efficient drying technology.

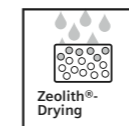

Using advanced drying technologies Siemens dishwashers keep energy consumption to a minimum. Zeolith®, a form of zeolite mineral has the astonishing ability to absorb moisture and convert it to heat. The heat produced naturally by the Zeolith® is used for the drying cycle. No additional energy is therefore required to heat up the contents of your dishwasher for the drying process (as with a standard drying system). This results in perfect drying, with less energy usage than models without Zeolith® technology.

Zeolith® is stored in the depths of the dishwasher; it regenerates itself and keeps working for the lifetime of the machine meaning you never have to replace it! Combine this with the economy 50°C programme to get brilliant results with minimal energy use.

Drying phase

Zeolith® absorbs moisture and converts it to heat energy.



Cleaning phase

As the mineral is heated during the cleaning cycle, it is recharged and ready to absorb moisture once more.





Model shown: SN87YX03CE
fully integrated dishwasher with blue emotionLight



varioDrawer

Dishcare key features

The priority zone for gentle and thorough washing of the most valuable glasses.



glassZone
Thanks to the glassZone, you can now put even your most valuable glasses in the dishwasher with peace of mind. Six integrated nozzles ensure continuous but gentle water supply and thus enable thorough cleaning without damaging sensitive materials. In addition, integrated soft anti-slip elements give secure hold, protect against mechanical stress and prevent damages of glass rims.



Create the perfect space in the dishwasher for your load.



rackMatic™
Available across all storage solutions, this feature conveniently allows the user to raise and lower the height of the top basket to create more or less space, even when the dishwasher is loaded.



Storage solutions for added flexibility and better results.

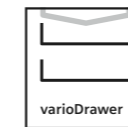

varioDrawer
By adding a third shelf for cutlery, varioDrawer removes the need for a cutlery basket and creates more space.



flex basket system
The flex basket has 2 flexible areas in the top rack and 4 in the bottom, giving you extra flexibility within the dishwasher to create more space for those larger items.



flexComfort basket system
These baskets have the ability to fold down certain compartments within the cavity for extra room – the top rack has 2 areas that can be adjusted for extra flexibility whilst the bottom basket has 8 areas that can be adjusted to create more space so the inside of your dishwasher is constantly adaptable. Anti-slip elements and stemware support hold have also been added, meaning it has never been as easy to load your dishwasher.



flexComfort Pro basket system
The flexComfort Pro basket system is designed to hold larger plates and allows you to create extra space for pots and pans with ease. Choose from up to 6 flexible areas in the top rack and up to 8 flexible areas in the bottom basket to create extra space. Blue touchpoints inside the baskets indicate all the adjustment options available at a glance, and the new easyGlide wheels on the upper basket make loading the dishwasher even easier. Other new features such as anti-slip elements and stemware support hold means you can easily and securely load your glassware and get on with your day, chore free.

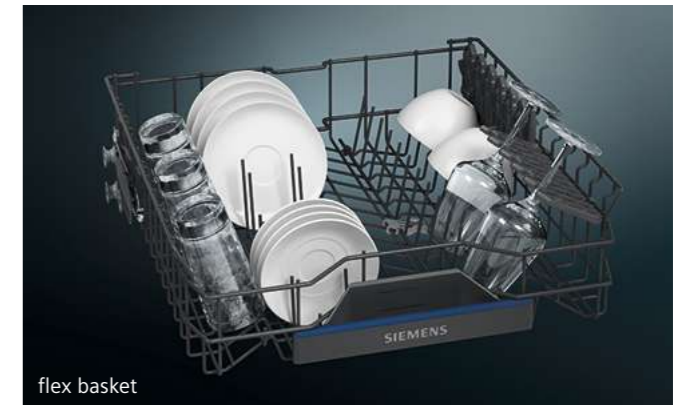

flex basket

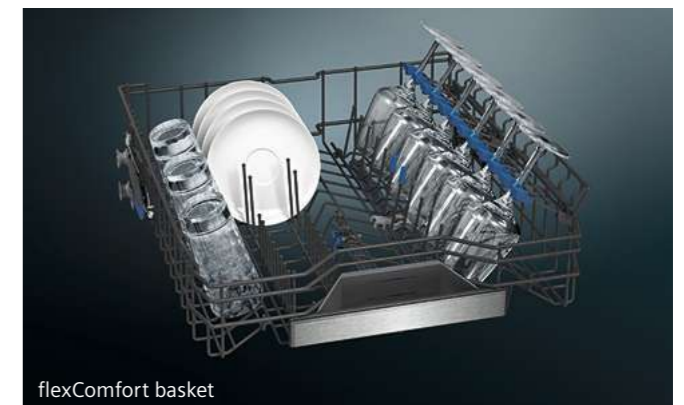

flexComfort basket



flexComfort Pro basket

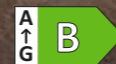

Model shown: SN87YX03CE
fully integrated dishwasher with blue emotionLight

Floor projection displays.

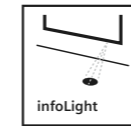

infoLight
Projects a beam of light onto the floor to show the dishwasher is running. This prevents needing to open the door while the cycle is still active to see if it is finished.

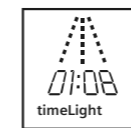

timeLight
Check the status of the cycle easily. Useable on any surface of any colour, the innovative timeLight projects the remaining time as well as other essential information of the dishwasher cycle onto the floor.

With quiet dishwashers, this solution lets you know the dishwasher is running and how long is left at a glance, so you can avoid opening the door mid-cycle.



Light up your dishwasher.



emotionLight
Siemens dishwashers feature an internal blue emotionLight that has the wow-factor. Creating a relaxed ambiance, the emotionLight uses LED lights to reflect off your brilliantly-cleaned glasses and create a cool blue glow emanating from inside your dishwasher when you open the door, and switching off again when you close it.

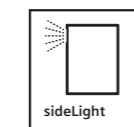

sideLight
With the sideLight, you can see immediately whether the washing programme is still running. During operation, the blue light strip illuminates the furniture gap on the left hand side of the dishwasher. Only available on selected varioHinge model (SN95ZX61CG).



Added kitchen convenience.



autoOpen dry
Gentle drying thanks to autoOpen dry. During the drying process, the door opens automatically and gently. This allows the natural drying of the dishes without the need for additional energy.



Silence programme
You'll barely hear our dishwashers running. When the Silence programme is selected the dishwasher's noise level is reduced by 2-3dB so you can relax in peace. This is achieved by decreasing water pressure and extending run time. Values stated in matrix under noise level.

Silence on demand
If you need silence during the wash cycle, why not pause the dishwasher for up to 30 minutes by selecting Silence on demand via the Home Connect App.



Hygiene Plus
Great for cleaning chopping boards, food containers and utensils, the hygiene option kills bacteria and germs. Providing a simple solution to the upkeep of your family's health, the final rinse heats up to 70°C regardless of the cycle you choose.*

*Not on delicate programme.

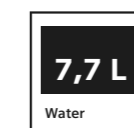

Water consumption
Our built-in dishwashers' lowest water usage programme is 7.7L per cycle* if the Eco 50 programme is selected, for the most resource efficient option.
*Based on SN95ZX61CG

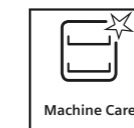

Machine Care with Siemens dishwashers
For excellent results when washing and drying, it is important to look after your dishwasher correctly. All of our integrated Siemens dishwashers include the Machine Care Programme.

This is designed to be used together with a dishwasher cleaning detergent and provides a short, high temperature, high pressure wash designed to remove limescale and grease build up inside your dishwasher and outlet pipes. The dishwasher will remind you every 30 cycles or so to run this programme, to keep your appliance running as efficiently as possible.

Discover top of the range displays



Choose the display type that is right for you.

Black touch control with TFT display and real-time clock
The clear, touch control high resolution TFT display makes it easy to select programmes and settings and check the status of your dishwasher at a glance. Thanks to the real-time clock, it is now possible to set the exact time that you want your dishes to be ready by, for extra convenience. Perfect for delivering warm plates to the dinner table.



Model shown: SN87YX03CE fully integrated dishwasher

Black touch control with LED display
Retaining the same top of the range sleek black touch control panel, however with a clear LED display screen which displays the programme setting and duration time.



Model shown: SN95ZX61CG fully integrated dishwasher

Black / Stainless Steel touch control button and LED display
Stylish and functional this two zone design with direct button selection and white LED display provides clear status information. When a programme and option is selected a blue LED illuminates under the button.



Model shown: SN63HX52CG fully integrated extra height 86.5cm dishwasher

Black push button control with toggle and LED display
With black buttons, a toggle screen and an LED screen which displays programme settings and duration time, this easy to use interface is practical and stylish.



Model shown: SN61HX02AG fully integrated dishwasher

varioHinge. The ideal solution for extra long cabinet doors.

varioHinge enables the furniture panel to slide up the appliance door as it opens, avoiding collision with the plinth.

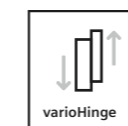

Siemens has two built-in 60cm dishwasher models, SN95ZX61CG, SN73HX42VG, plus a 45cm dishwasher SR93EX20MG, with varioHinge.

varioHinge ensures your kitchen design can be completely flexible with the installation of your dishwasher. Perfect for cabinet doors in handleless kitchens, or designs with low baseboards and longer cabinet panels, the varioHinge allows the cabinet door to be pushed upwards when opened to avoid the door catching. The varioHinge reduces the bottom gap between cabinet doors too for a seamless finish to your kitchen. These appliances are suitable for use with a 50mm plinth.

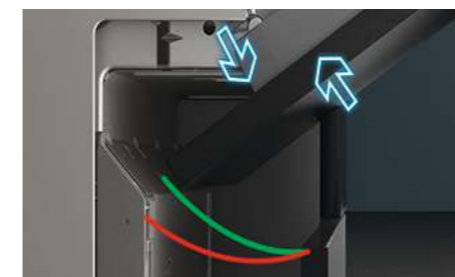

- ✓ Attractive design for high installation thanks to minimal gap size made possible by varioHinge.
- ✓ With varioHinge, a lower plinth height is possible.



Dishwashers with varioHinge – high installation

Take your mind off the household chores using the Home Connect App.

Connect your Wi-Fi-ready dishwasher with the Home Connect App to easily select programmes and options to start your dishwasher from wherever you are, whenever you want. Thanks to this app technology, you can control your appliance out of home and have the dishes ready exactly when you need them. Perfect for busy lifestyles. When the cycle is finished, the Home Connect App will send you a push notification to let you know, so you can focus on other things.

You can also select a number of great features through the Home Connect app, such as Speed on demand, Silence on demand, autoOpen Dry and you can set your Favourite programme and option combination, giving you flexibility to alter your wash cycle options from wherever you are to sync perfectly with your day.

Programme Assist menu

The Programme Assist menu on the Home Connect App helps you to find the correct setting for your load quickly and easily. Just answer a few simple questions and the app will suggest the most optimum programme for your load. It is easy to adjust your dishwasher settings via the app on your mobile or tablet to keep it running at maximum efficiency.

Home Connect partner Services

You can even use our partner services, Amazon Alexa and IFTTT to manage your machine. With Amazon Alexa, you can control your appliance by using your voice. Whether you want to start or finish the cycle, or check the remaining cycle time, just ask Alexa. Also works with Google assistant.

You can also benefit from automatic tablet replenishment, through Smart reorder within the Amazon Alexa app. This feature can be set up easily, so you never need to worry about running out of tablets again.

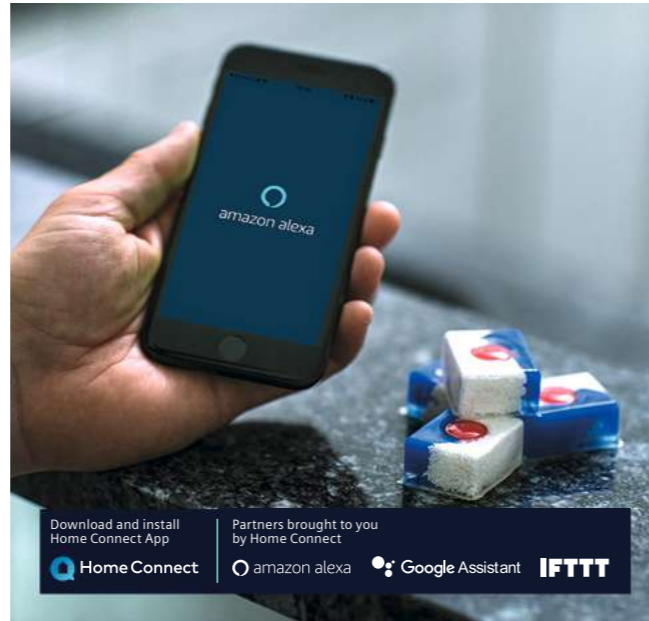

Setting your water settings has never been easier too. Whether your area experiences hard or soft water, you can set this easily within the app in seconds.

IFTTT technology allows you to integrate the Home Connect App with a wider array of connect devices. You can then produce customised applets, demands between two devices, so you can really bring your smart home to life. For example you could make your lights flash when your cycle finishes.

Learn more about Home Connect by visiting Siemens Home UK: www.siemens-home.bsh-group.com/uk



Features available on all dishwasher models.



varioSpeed Plus

Use the varioSpeed Plus button to run the dishwasher significantly faster without compromising on wash quality. Standard on all models.

Speed on demand

An advanced functionality of varioSpeed Plus that cleans and dries the dishes in the shortest possible time for individual needs. This option can be selected, even if a programme is already running, activate this feature via the Home Connect App.

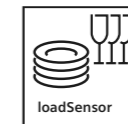

loadSensor

By monitoring that the optimum amount of water is flowing through the dishwasher throughout the cycle, loadSensor helps to ensure that dishes are cleaned thoroughly.



Favourite

Your personal favourites in one push: The Favourite button makes your dishwasher even more personal. Simply enter your most used combination of dishwashing programmes and options, and then start them conveniently at the touch of a button, via the Home Connect app or via your voice assistant.



dosageAssist

Quickly and evenly dissolves dishwasher tablets throughout the entire machine, leaving no mess to clean at the end of the cycle. This also prevents the tablet getting stuck in your dishware ensuring no cleaning product residue is left after the cycle.

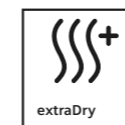

extraDry

The extraDry option can be added to any programme and will extend the drying cycle. This can be useful for harder to dry loads.

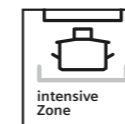

intensiveZone

Delicate items and pots and pans can be cleaned together in the same wash. The intensiveZone option increases the spray pressure and temperature in the bottom basket to handle burnt on pans, whilst delicate items can be washed safely in the top basket.

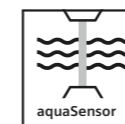

aquaSensor

Makes sure that the optimum temperature is used depending on how dirty the dishes are, meaning that dishes are perfectly clean the first time round.

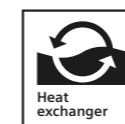

Heat exchanger

Protect your glasses from cracking with gentle water heating. Heat generated during the wash cycle is used to pre-heat the rinsing water to stop glasses being put under stress. Standard on all models.

A modern handleless kitchen.



openAssist

With door openAssist you can open fully integrated dishwashers by simply touching the front of the unit, making loading and unloading easy. This removes the need for a handle and is the ideal choice for designer kitchens. With this feature you can even implement a child lock so that the appliance requires two gentle touches before opening.

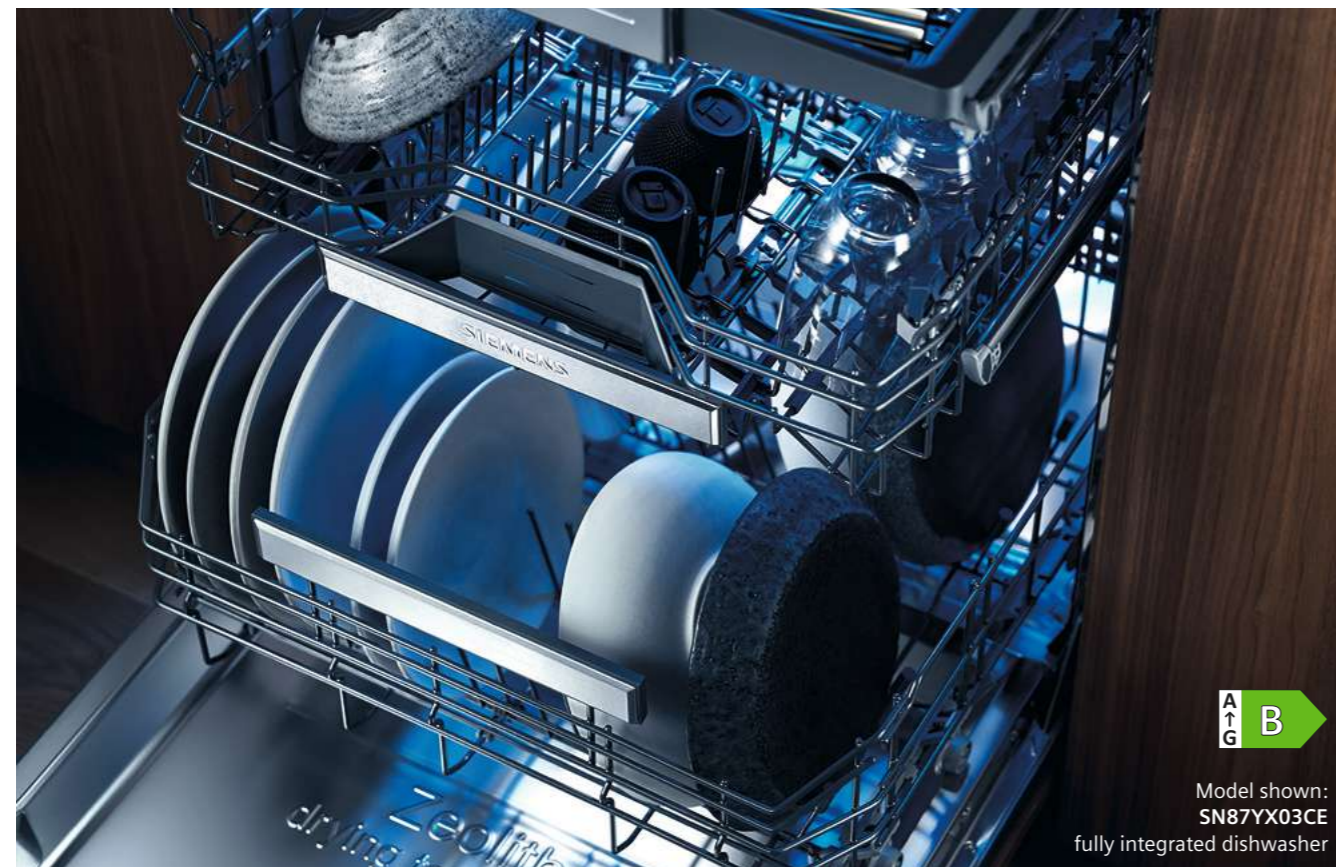

Standard 60cm dishwashers

iQ 700 SN87YX03CE

60cm fully integrated dishwasher

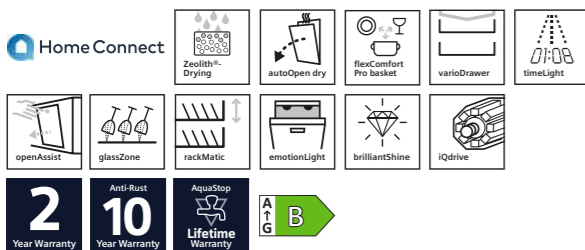

flexComfort Pro basket system

flexComfort Pro baskets create extra room for pots and pans. With an optimised lower basket design for large plates and adjustable sides highlighted with blue touchpoints, your dishwasher can adapt to any load quickly and easily.

varioDrawer included

Selected models include a varioDrawer, giving you a third loading level for cutlery and removing the need for a cutlery basket. This creates more room for large pots and pans below and includes space for small items such as ladles and espresso cups.

60cm dishwasher specifications

APPLIANCE TYPE	60CM FULLY INTEGRATED DISHWASHER
Design family	iQ 700
Model number	SN87YX03CE
Control panel colour	Black
Height (cm) / Hinge type	81.5 / Normal hinge
DESIGN FEATURES	
Drying system	Heat exchanger + drying assist, Zeolith
Home Connect Wi-Fi connectivity	■
Control panel type	Touch control + LED
Basket description	flexComfort Pro
varioDrawer (3rd loading level)	■
Status indicator	timeLight (White)
Door openAssist	■
glassZone	■
Glass care technology	■
Anti-slip protection and stemware support upper basket	■
Adjustable upper basket	rackMatic™ 3-stage
Number of flip tines in upper / lower basket	6 / 8
Cup shelves upper / lower baskets	1 / 1
Cutlery holder lower basket	-
Largest loadable dish upper / lower basket (cm)	21 / 31
Load / aquaSensor	■
Real-time clock	-
Start delay time max hours	24
Emotion light (interior lighting)	■
End of cycle indicator	Acoustic
Salt / Rinse aid light indicator	■ / ■
Self cleaning filter system	■
Flood protection system	AquaStop Plus 24h
Safety features	Door lock
PROGRAMMES / FUNCTIONS	
List of programmes	Eco 50°C, Auto 45-65°C, Intensive 40°C, Intensive 70°C, Speed 60°C, brilliantShine 40°C, Silence 50°C, Favourite, Machine Care
Additional operational options	Remote Start, Shine & Dry, intensiveZone, Hygiene Plus, varioSpeed Plus
TECHNICAL INFORMATION	
Reference programme for measurements	Eco 50°C
Energy efficiency class ¹	A B
Energy ² / water ³ (kWh / litres)	65 / 9.5
Load capacity (place settings)	14
Programme duration ⁴ (h:min)	3:55
Noise level (dB [A] re 1pW)	43
Noise efficiency class	B
Noise level (silence programme) (dB [A] re 1pW)	41
Length of electrical supply cord (cm)	175
Length inlet / outlet hose (cm)	165 / 190
Maximum height for installation (mm)	875
Maximum height adjustability feet (mm)	60
Maximum width for installation (mm)	608
Height of the product (mm)	815
Width / Depth of the product (mm)	598 / 550
Net weight / Gross weight (kg)	45.2 / 47.5
Water softener ⁵	■
Maximum accepted water hardness (°DH)	50
Maximum temperature for water intake (°C)	60
Interior cavity	Stainless steel
Included accessories	Steam protection plate

■ Yes, model has this feature. — Feature not available for this model.

¹ On an energy-efficiency class scale from A to G.

² Energy consumption in kWh/100 operating cycles (using Eco programme).

³ Water consumption in litres/operating cycle (using Eco programme).

⁴ Duration of Eco programme.

⁵ We would recommend our dishwashers are connected to the mains water supply where possible. However, they may also be connected to an external water softener as long as the water softener produces softened water of less than 1.1 mmol/litre (7.0°e) and the water softener in the appliance is turned off. Please contact product advice for further information. Water pressure required: 0.5-10 Bar. Flow rate: 10 litres per minute. Inlet valve connected directly to 3/4" screwed joint.

Data valid in this table as of June 2022. Subject to modification without prior notice.

60cm dishwasher specifications

APPLIANCE TYPE	60CM FULLY INTEGRATED DISHWASHERS		
Design family	iQ 500	iQ 500	iQ 500
Model number	SN85T00CE	SN95ZX61CG	SN85EX69CG
Control panel colour	Black	Black	Black
Height (cm) / Hinge type	81.5 / Normal hinge	81.5 / varioHinge	81.5 / Fixed
DESIGN FEATURES			
Drying system	Heat exchanger + drying assist, Zeolith	Zeolith	Heat exchanger / autoOpen dry
Home Connect Wi-Fi connectivity	■	■	■
Control panel type	Touch control + LED	Touch control + LED	Touch control + LED
Basket description	flexComfort	flexComfort	flexComfort
varioDrawer (3rd loading level)	■	■	■
Status indicator	timeLight (White)	sideLight (Blue)	timeLight (White)
Door openAssist	■	■	■
glassZone	■	■	-
Glass care technology	■	■	■
Anti-slip protection and stemware support upper basket	■	■	■
Adjustable upper basket	rackMatic™ 3-stage	rackMatic™ 3-stage	rackMatic™ 3-stage
Number of flip tines in upper / lower basket	2 / 8	2 / 8	2 / 8
Cup shelves upper / lower baskets	1 / 1	2 / 2	2 / 2
Cutlery holder lower basket	-	-	-
Largest loadable dish upper / lower basket (cm)	21 / 31	21 / 31	21 / 31
Load / aquaSensor	■	■	■
Real-time clock	-	-	-
Start delay time max hours	24	24	24
Emotion light (interior lighting)	■	■	■
End of cycle indicator	Acoustic	Acoustic	Acoustic
Salt / Rinse aid light indicator	■ / ■	■ / ■	■ / ■
Self cleaning filter system	■	■	■
Flood protection system	AquaStop Plus 24h	AquaStop 24h	AquaStop 24h
Safety features	Door lock	Door lock	Door lock
PROGRAMMES / FUNCTIONS			
List of programmes	Eco 50°C, Auto 45-65°C, Intensive 70°C, Speed 60°C, Speed 45°C, brilliantShine 40°C, Silence 50°C, Favourite, Machine Care	Eco 50°C, Auto 45-65°C, Intensive 70°C, Speed 60°C, Speed 45°C, brilliantShine 40°C, Silence 50°C, Favourite, Machine Care	Eco 50°C, Auto 45-65°C, Intensive 70°C, 1 hour 65°C, Speed 45°C, Glass 40°C, Silence 50°C, Favourite, Machine Care
Additional operational options	Remote Start, Shine & Dry, intensiveZone, varioSpeed Plus	Remote Start, Shine & Dry, intensiveZone, varioSpeed Plus	Remote Start, intensiveZone, Half Load, varioSpeed Plus
TECHNICAL INFORMATION			
Reference programme for measurements	Eco 50°C	Eco 50°C	Eco 50°C
Energy efficiency class ¹	A B	A C	A D
Energy ² / water ³ (kWh / litres)	54 / 9.5	74 / 7.7	85 / 9.5
Load capacity (place settings)	14	13	14
Programme duration ⁴ (h:min)	4:55	3:45	4:35
Noise level (dB [A] re 1pW)	44	44	39
Noise efficiency class	B	B	B
Noise level (silence programme) (dB [A] re 1pW)	42	42	37
Length of electrical supply cord (cm)	175	175	175
Length inlet / outlet hose (cm)	165 / 190	165 / 190	165 / 190
Maximum height for installation (mm)	865	875	875
Maximum height adjustability feet (mm)	60	60	60
Maximum width for installation (mm)	608	600	600
Height of the product (mm)	815	815	815
Width / Depth of the product (mm)	598 / 550	598 / 550	598 / 550
Net weight / Gross weight (kg)	43.7 / 46	43 / 45	35 / 38
Water softener ⁵	■	■	■
Maximum accepted water hardness (°DH)	50	50	50
Maximum temperature for water intake (°C)	60	60	60
Interior cavity	Stainless steel	Stainless steel	Stainless steel
Included accessories	Steam protection plate	Steam protection plate	Steam protection plate

■ Yes, model has this feature. — Feature not available for this model.

¹ On an energy-efficiency class scale from A to G.

² Energy consumption in kWh/100 operating cycles (using Eco programme).

³ Water consumption in litres/operating cycle (using Eco programme).

⁴ Duration of Eco programme.

⁵ We would recommend our dishwashers are connected to the mains water supply where possible. However, they may also be connected to an external water softener as long as the water softener produces softened water of less than 1.1 mmol/litre (7.0°e) and the water softener in the appliance is turned off. Please contact product advice for further information. Water pressure required: 0.5-10 Bar. Flow rate: 10 litres per minute. Inlet valve connected directly to 3/4" screwed joint.

Data valid in this table as of June 2022. Subject to modification without prior notice.

60cm dishwasher specifications



APPLIANCE TYPE	60CM FULLY INTEGRATED DISHWASHERS		
Design family	iQ300	iQ300	iQ300
Model number	SX93HX60CG	SN93HX60CG	SN73HX42VG
Control panel colour	Black / Stainless Steel	Black / Stainless Steel	Black / Stainless Steel
Height (cm) / Hinge type	86.5 / varioHinge	81.5 / varioHinge	81.5 / varioHinge
DESIGN FEATURES			
Drying system	Heat exchanger	Heat exchanger	Heat exchanger
Home Connect Wi-Fi connectivity	■	■	■
Control panel type	Push buttons + LED	Push buttons + LED	Push buttons + LED
Basket description	flex	flex	varioFlex
varioDrawer (3rd loading level)	■	■	■
Status indicator	sideLight (Blue)	sideLight (Blue)	infoLight (Blue)
Door openAssist	■	■	-
glassZone	-	-	-
Glass care technology	■	■	■
Anti-slip protection and stemware support upper basket	-	-	-
Adjustable upper basket	rackMatic™ 3-stage	rackMatic™ 3-stage	rackMatic™ 3-stage
Number of flip tines in upper / lower basket	2 / 4	2 / 4	2 / 4
Cup shelves upper / lower baskets	2 / 2	2 / 2	2 / -
Cutlery holder lower basket	-	-	-
Largest loadable dish upper / lower basket (cm)	21 / 34	21 / 31	21 / 31
Load / aquaSensor	■	■	■
Real-time clock	-	-	-
Start delay time max hours	24	24	24
Emotion light (interior lighting)	-	-	-
End of cycle indicator	Acoustic	Acoustic	Acoustic
Salt / Rinse aid light indicator	■ / ■	■ / ■	■ / ■
Self cleaning filter system	■	■	■
Flood protection system	AquaStop 24h	AquaStop 24h	AquaStop 24h
Safety features	Door lock	Door lock	Door lock
PROGRAMMES / FUNCTIONS			
List of programmes	Eco 50°C, Auto 45-65°C, Intensive 70°C, 1 hour 65°C, Speed 45°C, Favourite, Machine Care	Eco 50°C, Auto 45-65°C, Intensive 70°C, 1 hour 65°C, Speed 45°C, Favourite, Machine Care	Eco 50°C, Auto 45-65°C, Intensive 70°C, 1 hour 65°C, Speed 45°C, Silence 50°C, Favourite, Machine Care
Additional operational options	Remote Start, intensiveZone, Half Load, varioSpeed Plus	Remote Start, intensiveZone, Half Load, varioSpeed Plus	Remote Start, intensiveZone, Half Load, varioSpeed Plus
TECHNICAL INFORMATION			
Reference programme for measurements	Eco 50°C	Eco 50°C	Eco 50°C
Energy efficiency class ¹	D	D	E
Energy ² / water ³ (kWh / litres)	85 / 9.5	85 / 9.5	94 / 9.5
Load capacity (place settings)	14	14	13
Programme duration ⁴ (h:min)	4:55	4:55	3:45
Noise level (dB [A] re 1pW)	44	44	46
Noise efficiency class	B	B	C
Noise level (silence programme) (dB [A] re 1pW)	-	-	-
Length of electrical supply cord (cm)	175	175	175
Length inlet / outlet hose (cm)	165 / 190	165 / 190	165 / 190
Maximum height for installation (mm)	925	875	875
Maximum height adjustability feet (mm)	60	60	60
Maximum width for installation (mm)	600	600	600
Height of the product (mm)	865	815	815
Width / Depth of the product (mm)	598 / 550	598 / 550	598 / 550
Net weight / Gross weight (kg)	35 / 38	35 / 38	37 / 39
Water softener ⁵	■	■	■
Maximum accepted water hardness (°DH)	50	50	50
Maximum temperature for water intake (°C)	60	60	60
Interior cavity	Stainless steel	Stainless steel	Stainless steel / Polimax
Included accessories	Steam protection plate	Steam protection plate	Steam protection plate

■ Yes, model has this feature. - Feature not available for this model.

¹ On an energy-efficiency class scale from A to G.

² Energy consumption in kWh/100 operating cycles (using Eco programme).

³ Water consumption in litres/operating cycle (using Eco programme).

⁴ Duration of Eco programme.

⁵ We would recommend our dishwashers are connected to the mains water supply where possible. However, they may also be connected to an external water softener as long as the water softener produces softened water of less than 1.1 mmol/litre (7.0°e) and the water softener in the appliance is turned off. Please contact product advice for further information.

Water pressure required: 0.5-10 Bar. Flow rate: 10 litres per minute. Inlet valve connected directly to ¾" screwed joint.

Data valid in this table as of June 2022. Subject to modification without prior notice.

Slimline 45cm dishwashers

iQ300 SR93EX20MG

Fully integrated 45cm slimline dishwasher

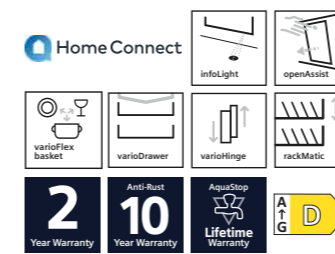

Slimline

Slimline dishwashers are perfect for kitchens with limited space. Despite the reduced size, you can still enjoy exciting features such as door openAssist and speed programmes.

Our 45cm dishwasher has a two zone design and features varioHinge, Home Connect, Speed on demand (via Home Connect app) and the Favourite programme (can set programme and option choice as favourite via the Home Connect app).

Speed on demand

You can speed up the programme at any time during the wash cycle, this option can be selected even if the programme has started unlike, varioSpeed+ (this would need to be selected before the start of the programme). To activate Speed on demand you need to access the Home Connect app.

45cm dishwasher specifications

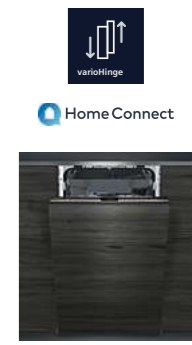

APPLIANCE TYPE	45CM FULLY INTEGRATED DISHWASHER
Design family	iQ300
Model number	SR93EX20MG
Control panel colour	Black / Stainless Steel
Height (cm) / Hinge type	81.5 / varioHinge
DESIGN FEATURES	
Drying system	Heat exchanger
Home Connect Wi-Fi connectivity	■
Control panel type	Push buttons + LED
Basket description	varioFlex
varioDrawer (3rd loading level)	■
Status indicator	infoLight (Blue)
Door openAssist	-
glassZone	-
Glass care technology	■
Anti-slip protection and stemware support upper basket	-
Adjustable upper basket	rackMatic™ 3-stage
Number of flip tines in upper / lower basket	2 / 2
Cup shelves upper / lower baskets	1 / 1
Cutlery holder lower basket	-
Largest loadable dish upper / lower basket (cm)	21 / 31
Load / aquaSensor	■
Real-time clock	-
Start delay time max hours	24
Emotion light (interior lighting)	-
End of cycle indicator	Acoustic
Salt / Rinse aid light indicator	■ / ■
Self cleaning filter system	■
Flood protection system	AquaStop 24h
Safety features	Door lock
PROGRAMMES / FUNCTIONS	
List of programmes	Eco 50°C, Auto 45-65°C, Intensive 70°C, 1 hour 65°C, Speed 45°C, Favourite, Machine Care
Additional operational options	Remote Start, intensiveZone, Hygiene Plus, varioSpeed Plus
TECHNICAL INFORMATION	
Reference programme for measurements	Eco 50°C
Energy efficiency class ¹	D
Energy ² / water ³ (kWh / litres)	67 / 9.5
Load capacity (place settings)	10
Programme duration ⁴ (h:min)	3:30
Noise level (dB [A] re 1pW)	45
Noise efficiency class	C
Noise level (silence programme) (dB [A] re 1pW)	-
Length of electrical supply cord (cm)	175
Length inlet / outlet hose (cm)	165 / 205
Maximum height for installation (mm)	875
Maximum height adjustability feet (mm)	60
Maximum width for installation (mm)	450
Height of the product (mm)	815
Width / Depth of the product (mm)	448 / 550
Net weight / Gross weight (kg)	32 / 34
Water softener ⁵	■
Maximum accepted water hardness (°DH)	50
Maximum temperature for water intake (°C)	60
Interior cavity	Stainless steel
Included accessories	Steam protection plate

■ Yes, model has this feature. - Feature not available for this model.

¹ On an energy-efficiency class scale from A to G.

² Energy consumption in kWh/100 operating cycles (using Eco programme).

³ Water consumption in litres/operating cycle (using Eco programme).

⁴ Duration of Eco programme.

⁵ We would recommend our dishwashers are connected to the mains water supply where possible. However, they may also be connected to an external water softener as long as the water softener produces softened water of less than 1.1 mmol/litre (7.0°e) and the water softener in the appliance is turned off. Please contact product advice for further information. Water pressure required: 0.5-10 Bar. Flow rate: 10 litres per minute. Inlet valve connected directly to ¾" screwed joint.

Data valid in this table as of June 2022. Subject to modification without prior notice.

Laundry care, high performance with state-of-the-art technology

Siemens has created a built-in laundry range that is cleverly designed and quietly efficient, developed to make laundry easier and less of a chore.

Our machines take full advantage of the latest technology and innovation all behind closed doors. Cleverly designed and quietly efficient, our built-in washing machines and washer dryers produce beautifully clean clothes whilst fitting seamlessly into your kitchen. Performance behind the door.



Home laundry

Siemens home laundry warranties:



2 Year Warranty

A Two Year Warranty is available on all Siemens washing machines and washer dryers listed in this brochure to protect against manufacturing and material faults during this warranty period.

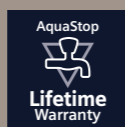

AquaStop Lifetime Warranty

Selected Siemens laundry appliances have a lifetime AquaStop warranty to protect against water damage caused by a defective AquaStop system. For models with this warranty please check the matrix.



iQdrive® Motor 10 Year Warranty

The iQdrive® Motor Warranty is available on selected laundry machines to protect against any defects to the iQdrive® motor. For models with this warranty please check the laundry matrix.

To find out more about your warranty and for registration, please refer to page 175.

Laundry care key features



Efficient Laundry appliances that can be concealed neatly behind the door, helping to retain clean lines and modern aesthetics, with a range of key features that all help to make laundry less of a chore.



Model shown above: WI14W502GB washing machine

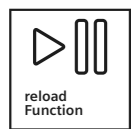

reload
The reload function allows the machine to be paused and the door opened at the next safe opportunity. It is the perfect solution when an extra item needs to be added to the load.



quietWash programme
Particularly quiet wash programme with a reduced final spin to wash and dry up to 4kg.

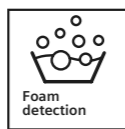

Foam detection
Detects if too much foam has been created in the wash, if so, it will adjust the drum movement and add an extra rinse cycle if necessary.



rapid15
Washes, rinses and spins lightly soiled clothing in just 15 minutes. Designed for those with busy lifestyles, this wash cycle will clean clothes when you are in a hurry.

Extremely quiet washing machines
Thanks to the brushless iQdrive motor and antiVibration side panels, Siemens built-in washing machines are particularly quiet in their class.

Extremely quiet washer dryers
Our washer dryers are designed to be as quiet as possible while still offering excellent performance and results when washing and drying, so you can get on with your day without any disturbance.



Wool programme
An exceptionally gentle woollen hand wash programme. The drum is set to provide a cradle motion, with only an occasional rotation, giving a soft wash action. A special spin phase finishes the cycle.



Shirts/Blouses
The ideal programme for a week's worth of shirts, offering a reduced spin to reduce ironing. Suitable for up to 2kg worth of washing, this cycle is designed to run for just over an hour.



Mixed fabrics
Perfect for the mid-week wash of a mixture of cottons, hard-wearing or easy-care fabrics, load up to 4kg worth of garments with a running time of just 49 minutes.



Delicates/silk
This gentle programme is perfect for those delicate, washable fabrics, e.g. silk, satin, synthetics or blended fabrics (e.g. curtains). Cool temperatures, gentle spinning between the rinse cycles and reduced final spin speeds reduces creases dramatically.



Model shown: WI14W502GB washing machine

The complete laundry solution with features that fit around your lifestyle

Features specific to washing machines.

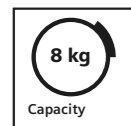

Capacity
The large 8kg drum capacity is the perfect size to hold more laundry and reduce the number of loads you have to wash.



Drum Clean
An automatic alert after 20 washes to run the Drum Clean programme on a 90°C or 60°C wash keeps the appliance clean and odour free.

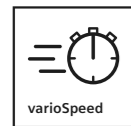

varioSpeed
Get perfectly clean laundry in up to 55% less time. This feature can automatically detect when time can be saved. The smart sensor identifies load volume and textile kind, hence adapting the washing machine's process time efficiently to suit the specific load.

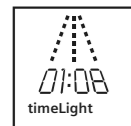

timeLight
Stay in control and let the laundry fit around you. The timeLight projects the remaining cycle time and programme status onto any floor surface to keep you informed at a glance, and is visible without opening the cabinet door.



Model shown: WI14W502GB washing machine



Features specific to washer dryers.

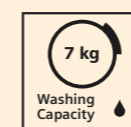

Washing capacity
The large 7kg washing capacity ensures you can wash clothes with fewer loads.

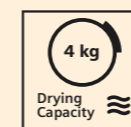

Drying capacity
The 4kg drying capacity ensures you can dry clothes effectively.

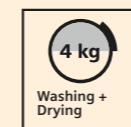

Washing + Drying
The continuous washing and drying cycle is suitable for loads up to 4kg. This cycle will first wash the clothes on your chosen setting and once finished, will automatically switch to drying the clothes for ease and speed.

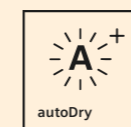

autoDry
Gently dries laundry to the exact degree of dryness you want.



ActiveWater™
Helps to reduce water consumption thanks to a 2-step automatic load adjustment system.



Fluff removal programme
A ten minute fluff removal cycle on washer dryers that removes fluff deposits in the machine. A light indicates when this is needed.



Outdoor
Specialised programme for washing waterproof clothing with membrane technology to protect the fabric and seams. For use with outdoor fabric detergent.

Washing machines

IQ700 WI14W502GB

Washing machine
White 1400rpm spin speed

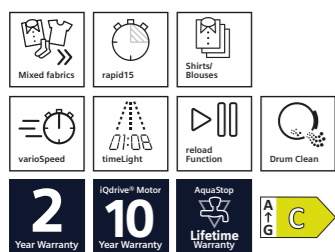

Integrated washing machine specifications



APPLIANCE TYPE	WASHING MACHINES
Design family	IQ700
Model number	WI14W502GB
Availability	Available
PROGRAMMES / FUNCTIONS	
Standard Programmes	
Eco 40-60	■
Cottons	■
Easy-care programme	■
Wool programme	■
Delicates/silk	■
Mixed fabrics	■
Additional Programmes	
rapid15 / rapid30	■
rapid60	■
Outdoor (waterproofing)	■
Shirts/blouses	■
Duvet	■
Dark Wash	■
Hygiene 60°C	■
Reduced noise wash	■
Spin / Drain	■
Rinse	■
Options	
Extra rinse	■
Prewash	■
Variable temperature	■
Variable spin	■
varioSpeed	■
ADDITIONAL FEATURES	
timeLight	■
iQDrive®	■
AquaStop	■
reload	■
Foam detection	■
Drum Clean	■
PERFORMANCE & CONSUMPTION	
Energy efficiency class ¹	A
Load capacity (kg)	1 - 8
Energy ² / Water ³ (kWh / litres)	62 / 45
Programme duration ⁴ (h:mm)	3:26
Maximum spin speed (rpm) ⁵	1400
Spin efficiency class	B
Noise level (dB [A] re 1pW)	66
Noise emission class	A
Drum volume (litres)	55
TECHNICAL INFORMATION	
Dimensions of the product: H x W x D (inc. hinge and 19mm door) (cm)	81.8 x 59.6 x 54.4 (57.4)
Door opening angle	130°
Depth with door open 90° (cm)	96
Height adjustable by (cm)	1.2
Length of electrical supply cord (cm)	210
Length of supply hose/ drain hose (cm)	220 / 220
Door hinge (door porthole)	Left-hand
Cabinet colour	White

■ Yes, model has this feature. – Feature not available for this model.

¹ On an energy-efficiency class scale from A to G. ² Energy consumption in kWh/100 operating cycles (using Eco 40-60 programme). ³ Water consumption in litres/operating cycle (using Eco 40-60 programme). ⁴ Duration of Eco 40-60 programme. ⁵ The specified value is rounded.

Data valid in this table as of June 2022. Subject to modification without prior notice.

Integrated washing machine specifications



APPLIANCE TYPE	WASHING MACHINES		
Design family	IQ700	IQ500	IQ500
Model number	WI14W501GB	WI14W302GB	WI14W301GB
Availability	Discontinued July 2022	Available	Discontinued July 2022
PROGRAMMES / FUNCTIONS			
Standard Programmes			
Eco 40-60	■	■	■
Cottons	■	■	■
Easy-care programme	■	■	■
Wool programme	■	■	■
Delicates/silk	■	■	■
Mixed fabrics	■	■	■
Additional Programmes			
rapid15 / rapid30	■	■	■
rapid60	■	–	–
Outdoor (waterproofing)	■	–	–
Shirts/blouses	■	■	■
Duvet	■	–	–
Dark Wash	■	–	–
Hygiene 60°C	■	■	■
Reduced noise wash	■	■	■
Spin / Drain	■	■	■
Rinse	■	■	■
Options			
Extra rinse	■	–	–
Prewash	■	■	–
Variable temperature	■	–	–
Variable spin	■	■	■
varioSpeed	■	■	■
ADDITIONAL FEATURES			
timeLight	■	–	–
iQDrive®	■	■	■
AquaStop	■	■	■
reload	■	■	■
Foam detection	■	–	■
Drum Clean	■	–	–
PERFORMANCE & CONSUMPTION			
Energy efficiency class ¹	A	A	A
Load capacity (kg)	1 - 8	1 - 8	1 - 8
Energy ² / Water ³ (kWh / litres)	62 / 45	62 / 45	62 / 45
Programme duration ⁴ (h:mm)	3:16	3:26	3:16
Maximum spin speed (rpm) ⁵	1400	1400	1400
Spin efficiency class	B	B	B
Noise level (dB [A] re 1pW)	66	66	66
Noise emission class	A	A	A
Drum volume (litres)	55	55	55
TECHNICAL INFORMATION			
Dimensions of the product: H x W x D (inc. hinge and 19mm door) (cm)	81.8 x 59.6 x 54.4 (57.4)	81.8 x 59.6 x 54.4 (57.4)	81.8 x 59.6 x 54.4 (57.4)
Door opening angle	130°	130°	130°
Depth with door open 90° (cm)	95.6	96	95.6
Height adjustable by (cm)	1.2	1.2	1.2
Length of electrical supply cord (cm)	210	210	210
Length of supply hose/ drain hose (cm)	220 / 220	220 / 220	220 / 220
Door hinge (door porthole)	Left-hand	Left-hand	Left-hand
Cabinet colour	White	White	White

■ Yes, model has this feature. – Feature not available for this model.

¹ On an energy-efficiency class scale from A to G. ² Energy consumption in kWh/100 operating cycles (using Eco 40-60 programme). ³ Water consumption in litres/operating cycle (using Eco 40-60 programme). ⁴ Duration of Eco 40-60 programme. ⁵ The specified value is rounded.

Data valid in this table as of June 2022. Subject to modification without prior notice.

Washer dryers



iQ500 WK14D542GB

Washer dryer
White 1400rpm spin speed



Integrated washer dryer specifications

APPLIANCE TYPE	WASHER DRYERS	
	iQ500	iQ300
Design family	WK14D542GB	WK14D322GB
Model number	WK14D542GB	WK14D322GB
PROGRAMMES / FUNCTIONS		
Standard Washing Programmes		
Eco 40-60	■	■
Cottons	■	■
Easy-care programme	■	■
Wool programme	■	■
Delicates/silk	■	■
Rinse/Spin	■	■
Drain/Spin	■	■
Additional Programmes		
Hygiene	■	-
rapid15	■	-
Quiet wash	■	-
Shirts/blouses	■	-
Outdoor	■	-
Mixed fabrics	■	-
Drying programmes		
Gentle dry	■	■
Intensive dry	■	■
Fluff removal programme	■	■
Options		
flexiTime	■	■
Easy iron	■	■
Intensive	■	■
Water Plus	■	■
Rinse hold	■	■
Prewash	■	■
Variable spin / Variable temperature	■ / ■	■ / -
ADDITIONAL FEATURES		
autoDry	■	-
AquaStop	■	-
Foam detection	■	■
autoLoad	■	■
Time delay	24h	24h
PERFORMANCE & CONSUMPTION		
Energy efficiency class washing and drying ¹	A to G E	A to G E
Energy efficiency class washing ²	E	E
Energy ³ / Water ⁴ washing and drying (kWh / litres)	266 / 68	266 / 68
Energy ³ / Water ⁴ washing (kWh / litres)	77 / 44	77 / 44
Load capacity washing and drying / washing (kg)	4 / 7	4 / 7
Programme duration ⁵ washing and drying / washing (h:mm)	5:30 / 2:50	5:30 / 2:50
Spin efficiency class	B	B
Spin speed ⁶ (rpm)	1400	1400
Noise level (dB [A] re 1pW)	72	72
Noise emission class	A	A
Drum volume (litres)	52	52
TECHNICAL INFORMATION		
Dimensions of the product: H x W x D (inc. hinge and 19mm door) (cm)	82.0 x 59.5 x 56.0 (58.4)	82.0 x 59.5 x 56.0 (58.4)
Door opening angle	95°	95°
Depth with door open 90° (cm)	96	96
Height adjustable by (cm)	1.5	1.5
Length of electrical supply cord (cm)	220	220
Length of supply hose/ drain hose (cm)	200 / 200	200 / 200
Door hinge (door porthole)	Left-hand	Left-hand
Cabinet colour	White	White

■ Yes, model has this feature. - Feature not available for this model.

^{1,2} On an energy-efficiency class scale from A to G. ³ Energy consumption in kWh/100 complete operating cycles (using Eco 40-60 programme). ⁴ Water consumption in litres/complete operating cycle (using Eco 40-60 programme). ⁵ Energy consumption in kWh/100 wash cycles (using Eco 40-60 programme). ⁶ Water consumption in litres/wash cycle (using Eco 40-60 programme). ⁷ Duration of Eco 40-60 programme, complete operating cycle / wash cycle. ⁸ The specified value is rounded.

Data valid in this table as of June 2022. Subject to modification without prior notice.



Model shown: WK14D542GB washer dryer

Contact our dedicated customer service team

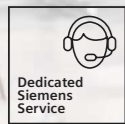

Dedicated Siemens Service
With our dedicated team of trained and qualified engineers available across the United Kingdom**, each having undergone over 400 hours of training, you can be confident that your Siemens appliances are in the safest of hands.

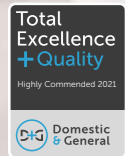

Customer service.

Trust Siemens Home Appliances Customer Service to help you with the following:

- Offer product advice on using your appliance or help with choosing a new Siemens appliance.
- Register your appliances and extend the warranty.
- Arrange a repair for your appliance by a Siemens engineer.*
- Locate and buy replacement spare parts and accessories.

We're available 24 hours a day, 7 days a week.
You can call us on: **UK: 0344 892 8979** **ROI: 01450 2655**

Our specialist advisors are available Monday to Friday 8am to 6pm, Saturday 9am to 5pm and Sunday 9am to 4pm. Calls are charged at the basic rate, please check with your telephone service provider for exact charges.

* In some areas we may use an approved service partner and the process may vary for repairs carried out by our service partners.
** In certain areas we may use an approved service partner.

Covid-19 Update.

Please note that due to the implications of COVID-19, our contact hours and service availability are subject to change. For the latest information and updates on our services, please visit the COVID-19 Service Update pages:
UK: www.siemens-home.bsh-group.com/uk/coronavirus **ROI: www.siemens-home.bsh-group.com/ie/coronavirus**

Engineer service.

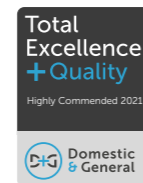

If your Siemens appliance needs a repair, we are here to help. Equipped to repair your appliance on the first visit, our team of locally based engineers are employed and trained by Siemens, which gives them unrivalled knowledge and expertise to repair our appliances.

You can easily book, and manage your engineer visit online at: **www.siemens-home.bsh-group.com/uk/customer-service/repair** or via our call centre (see left for contact details).

Republic of Ireland customers should call: **01450 2655**.

Calls are charged at the basic rate, please check with your telephone service provider for exact charges.

Warranties and Registration.

Register my appliance

Siemens recommends that you register all home appliances to ensure you can be easily contacted in the event of an important product update. For more information about registering appliances of all brands, please visit: www.registermyappliance.org.uk

2 Year Warranty
All Siemens home appliances have a Siemens Two Year Manufacturer's Warranty as standard to protect against manufacturing or material faults and defects during this warranty period.

To register call: **UK: 0800 519 2116** **ROI: 01230 0344**
Or register online: **UK: www.siemens-home.bsh-group.com/uk** **ROI: www.siemens-home.bsh-group.com/ie**

5 Year Warranty
A Siemens Five Year Warranty is available on studioLine Siemens appliances and selected freestanding models to protect against any manufacturing and material faults and defects during this warranty period.

To register call: **UK: 0344 892 8999** **ROI: 01450 2655**
Or register online: **UK: www.siemens-home.bsh-group.com/uk** **ROI: www.siemens-home.bsh-group.com/ie**

10 Year Compressor Drive Warranty
Available on all Siemens fridges and freezers, this warranty covers defects in the compressor motor.

10 Year iQdrive® Motor Warranty
Protects against manufacturing or material faults and defects to the iQdrive motor only during this warranty period. Selected laundry appliances only.

10 Year Anti-Rust Warranty for Dishwashers
Protects against rust in the inner cavity of the appliance during this warranty period. Applies to dishwasher appliances only.

Lifetime AquaStop Warranty
A lifetime warranty to protect against water damage caused by a defective AquaStop system. Applies to selected laundry and dishwasher appliances only.



Online help.

Prefer to receive help online?

Siemens offers a comprehensive range of online services in the high quality you have come to expect. Our online support allows you to familiarise yourself with your appliance, find user manuals, browse FAQ's, get useful tips and have full control over your engineer booking: **www.siemens-home.bsh-group.com/uk/customer-service**

Republic of Ireland customers:
www.siemens-home.bsh-group.com/ie/customer-service.
To book a repair, please call: **01450 2655**. Calls are charged at the basic rate, please check with your telephone service provider for exact charges.

Online shop.

Accessories and cleaning products.

You can find everything you need for any appliance on the Siemens online store. It is where you will find our tested and approved cleaning and care products to keep your appliances in tip top condition, along with other accessories ranging from a water filter for your fridge, to a Teppan Yaki for your hob.

Shop online at:
UK: www.siemens-home.bsh-group.com/uk/shop
ROI: www.siemens-home.bsh-group.com/ie/shop

Spare parts.

Siemens keeps a comprehensive range of replacement spare parts for up to ten years. You can browse our exploded view diagrams on our store or speak to an advisor on the phone to help you locate and buy the spare parts you need.

Shop online at:
UK: www.siemens-home.bsh-group.com/uk/shop/search-parts
ROI: www.siemens-home.bsh-group.com/ie/shop/search-parts

Brochures.

You can download PDF copies of our latest brochures from our website:



UK: www.siemens-home.bsh-group.com/uk/brochures
ROI: www.siemens-home.bsh-group.com/ie/brochures

SIEMENS



Product installation guide

Siemens Home Appliances

Oven technical diagrams

Single ovens HN678GES6B

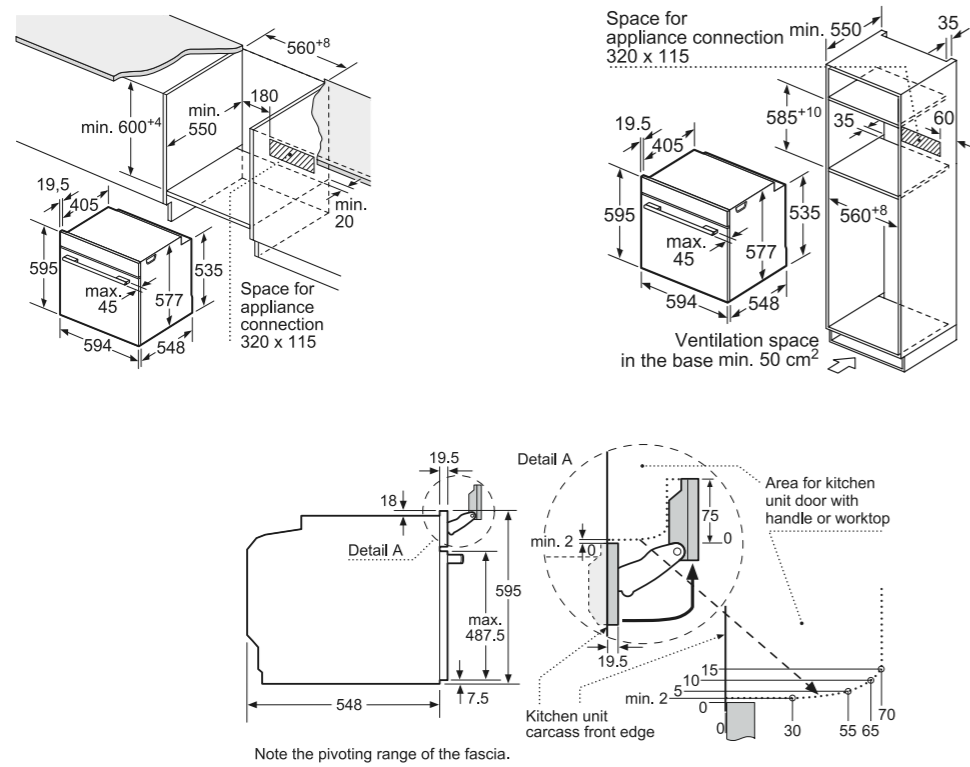

Single ovens HM678G4S6B, HM676G0S6B, HB676GBS6B and HB656GBS6B

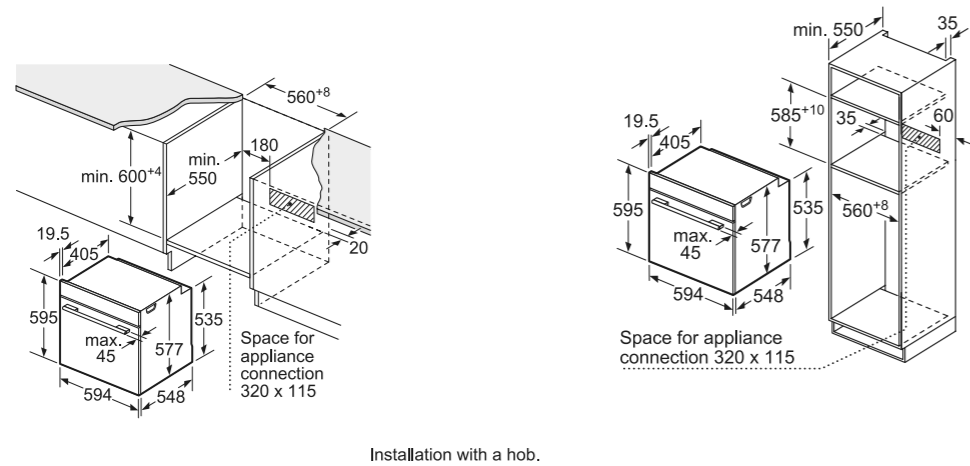

Single ovens HR678GES6B, HS658GES7B and HR676GBS6B

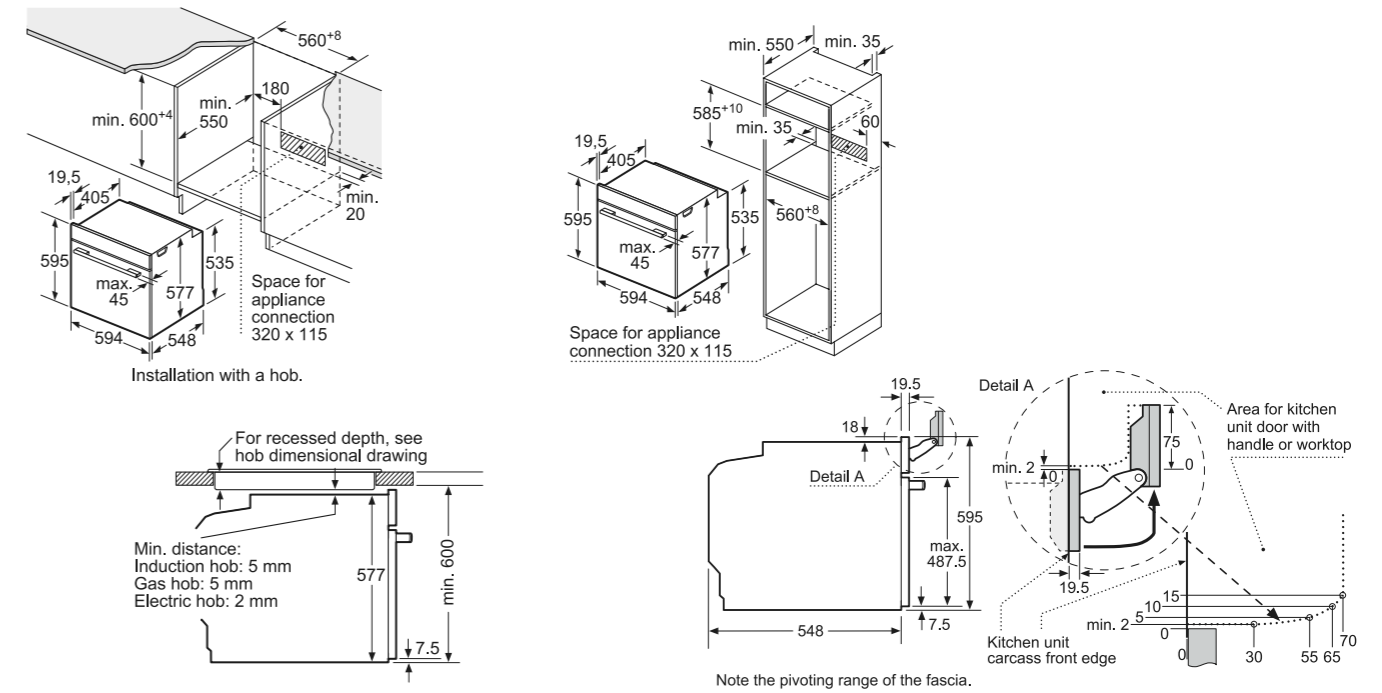

Single ovens HB678GBS6B, HB672GBS1B and HB632GBS1B

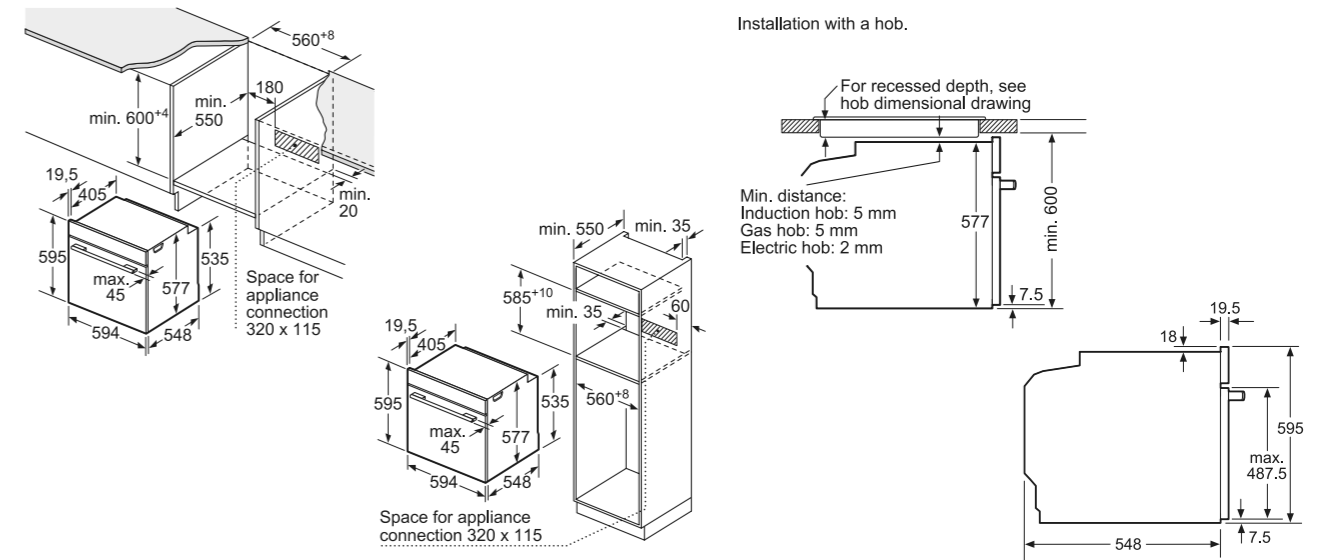

Single oven HM656GNS6B

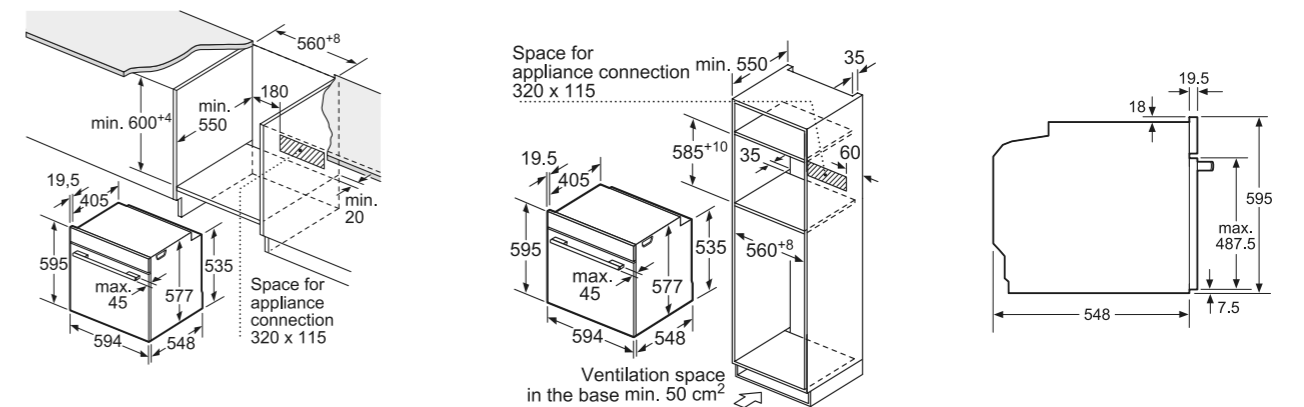

Oven technical diagrams

Single ovens HR578G5S6B and HB578G5S6B

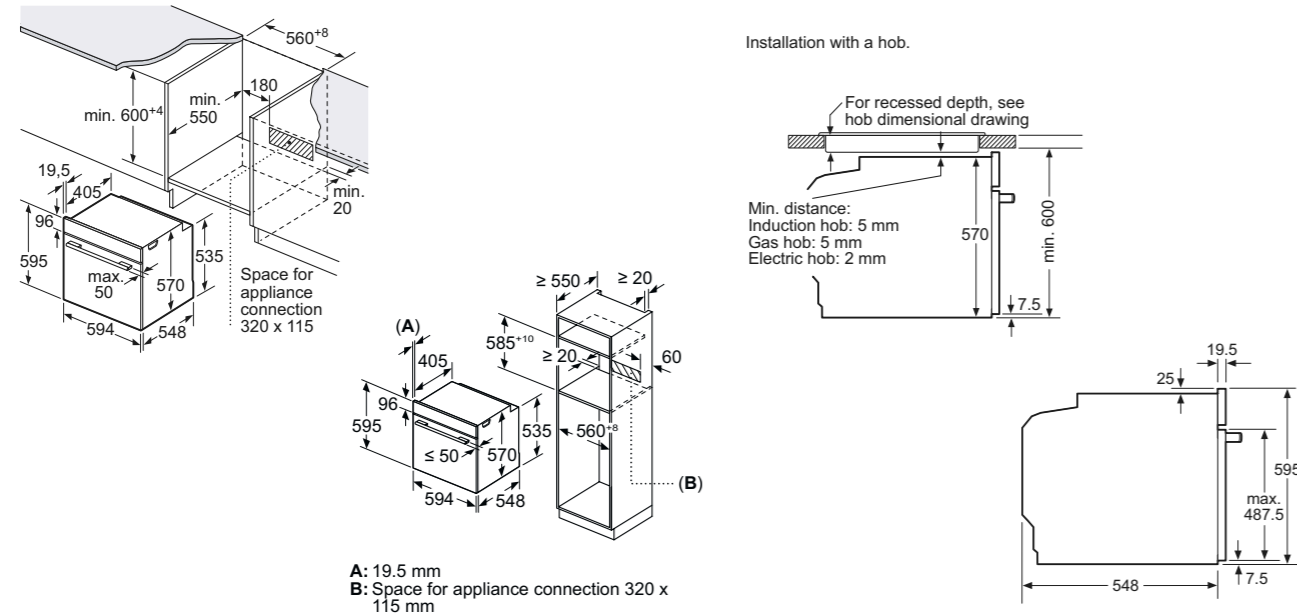

Single ovens HB578A0S6B and HB535A0S0B

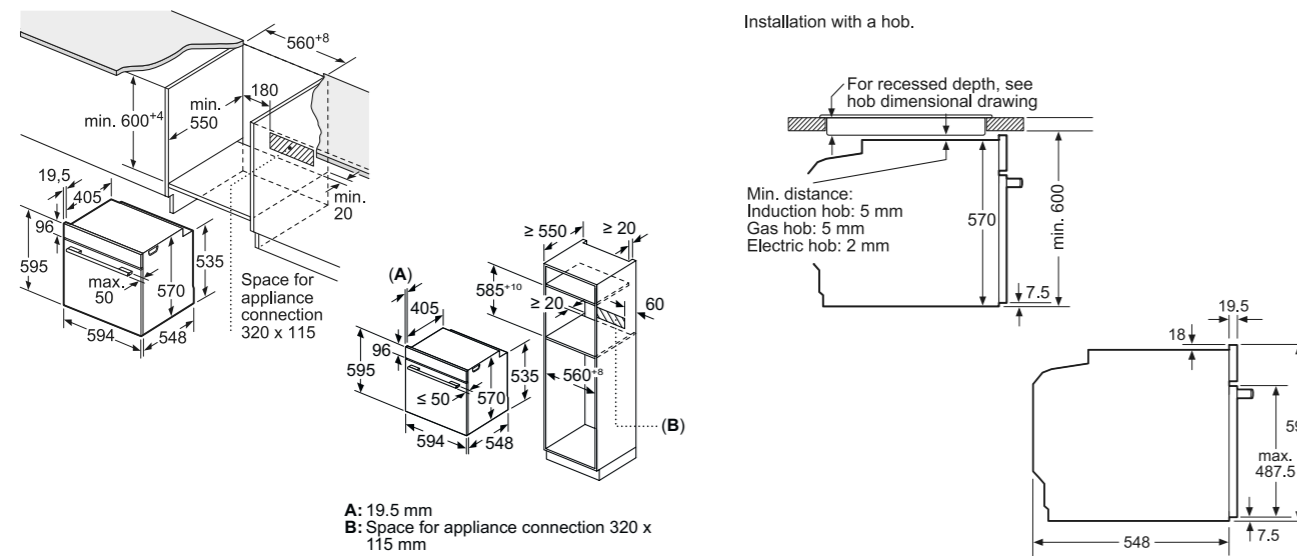

Double ovens MB578G5S6B, MB557G5S0B and MB535A0S0B

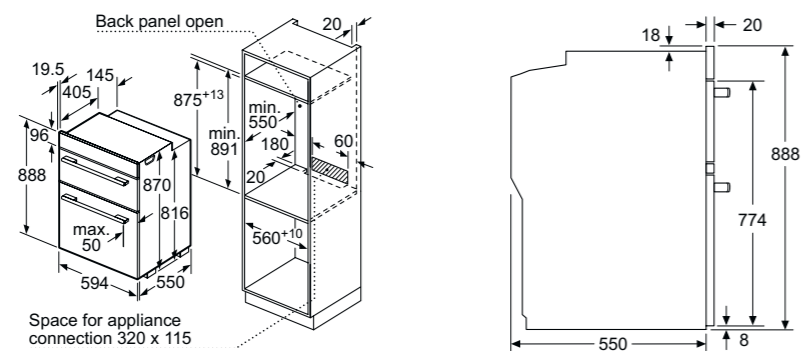

Built-under double oven NB535ABS0B

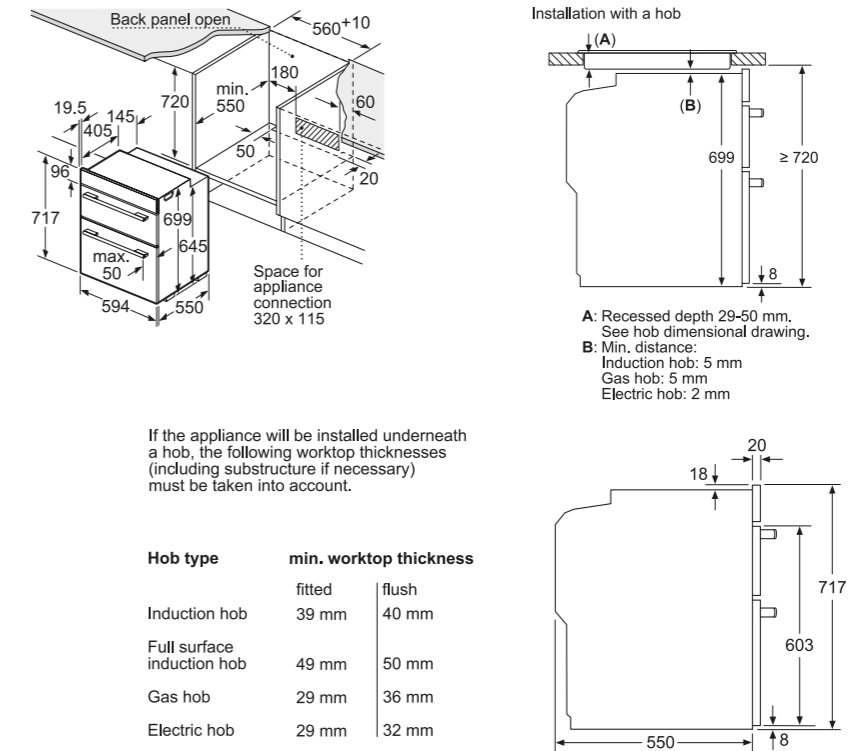

Compact ovens CM678G4S6B and CM676GBS6B

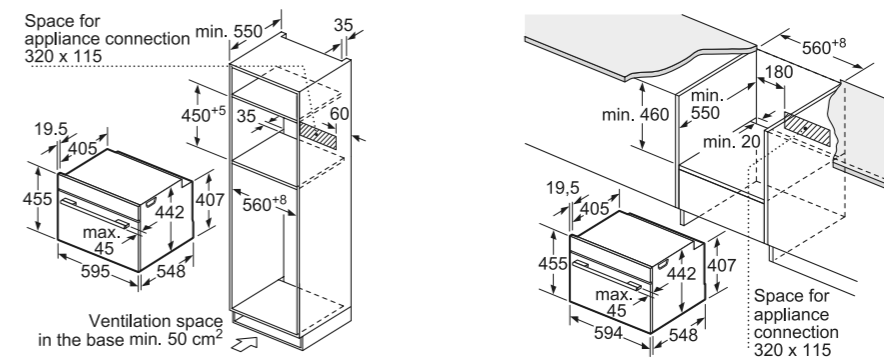

Oven technical diagrams

Compact ovens, compact steamers and compact microwave ovens CM656GBS6B, CS656GBS7B, CM633GBS1B and CD634GAS0B

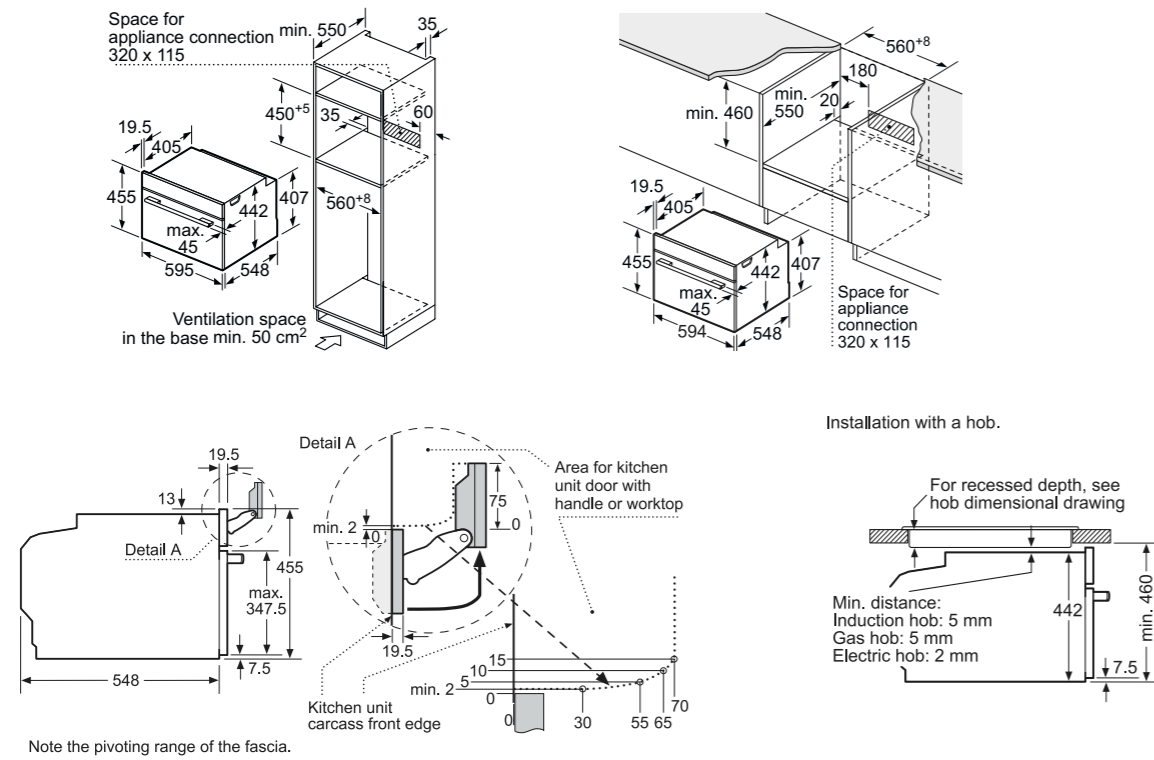

Compact microwave combination with steam CP565AGS0B

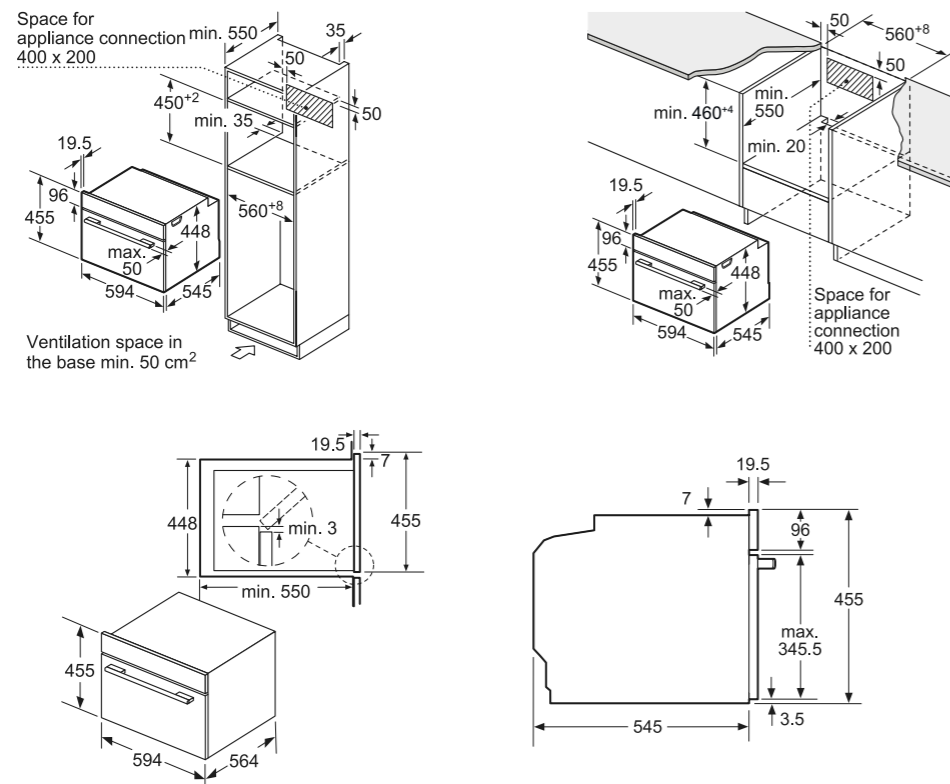

Microwave oven CF634AGS1B

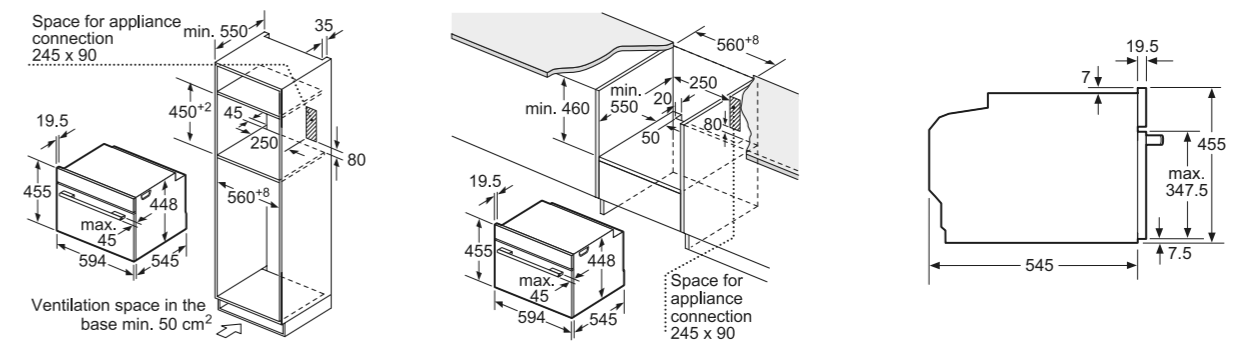

Compact microwave combination CM585AGS0B

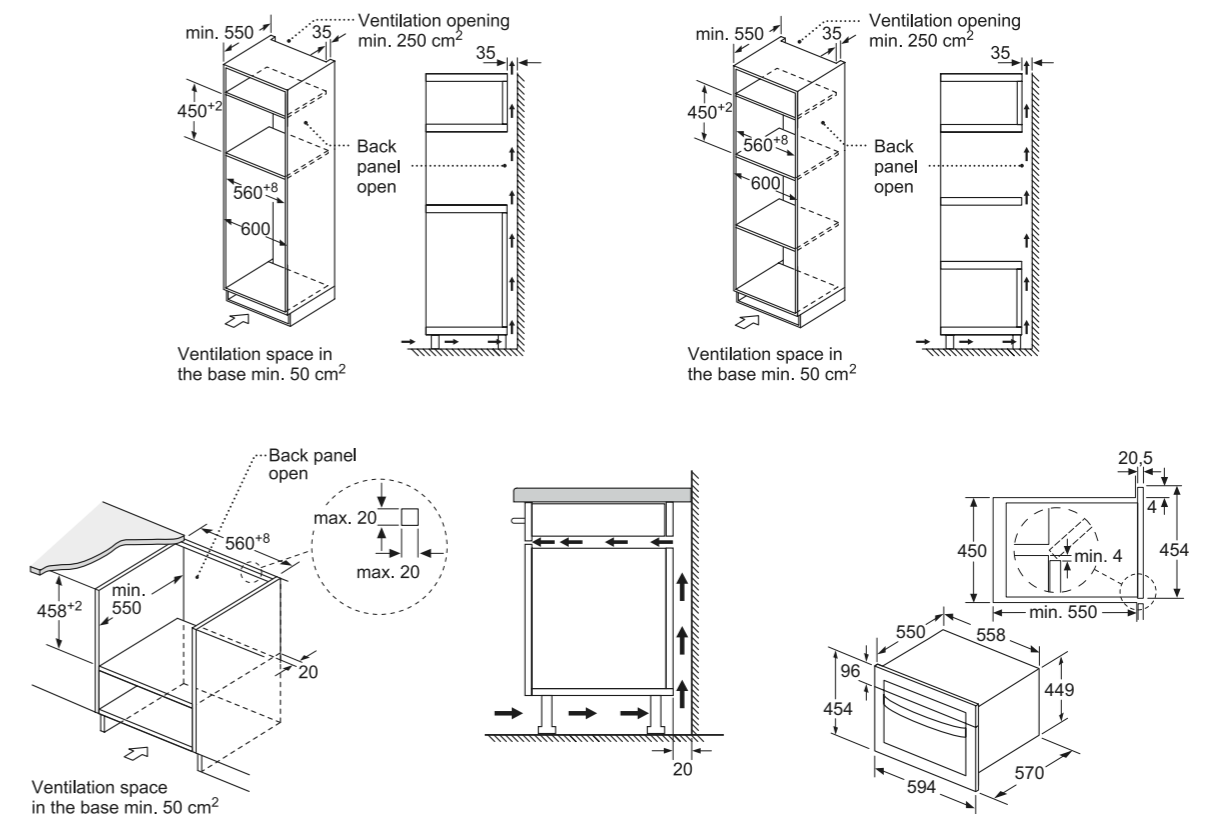

Microwave oven technical diagrams

Microwaves BE634LGS1B and BF634LGS1B

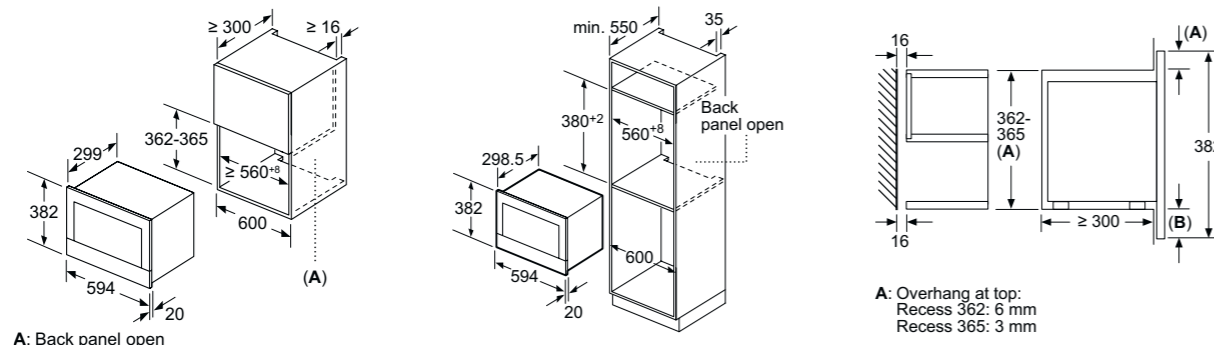

Microwave BF555LMS0B

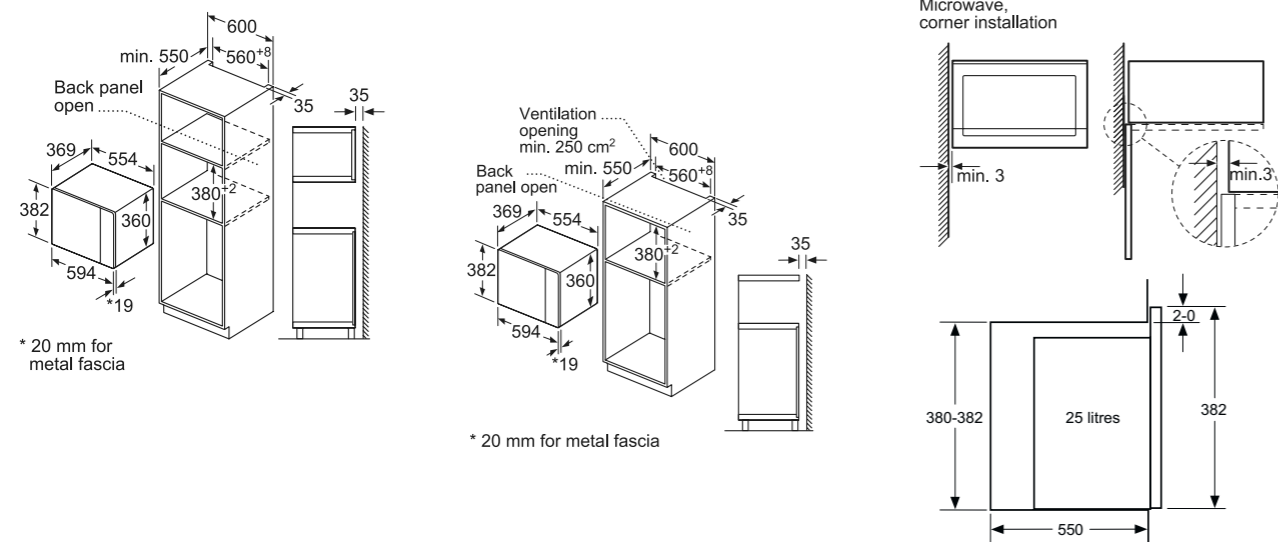

Microwave BF525LMS0B

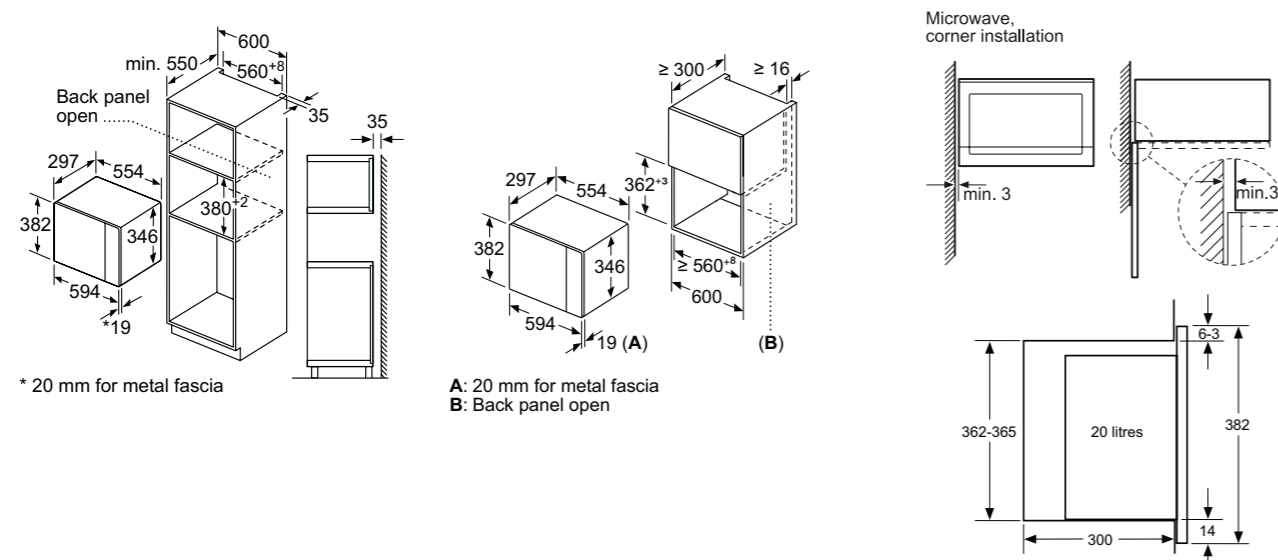

Warming drawer technical diagrams

Warming drawer BI630DNS1B

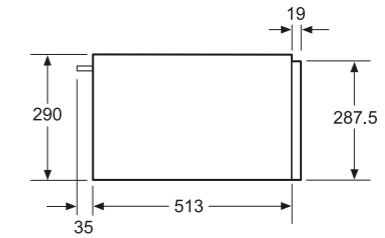
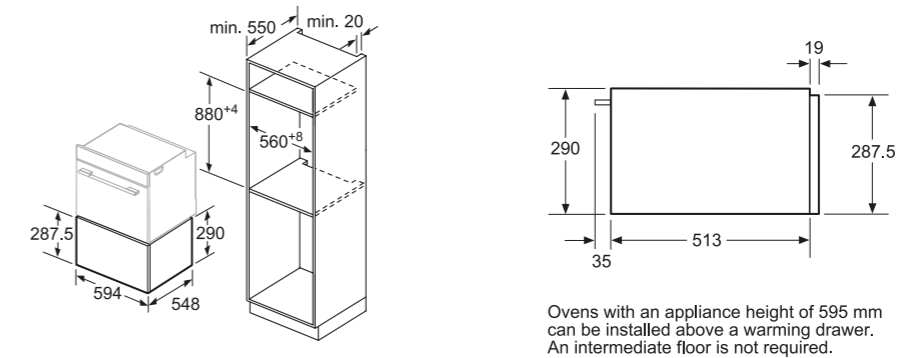

Ovens with an appliance height of 595 mm can be installed above a warming drawer. An intermediate floor is not required.

Warming drawers BI630CNS1B

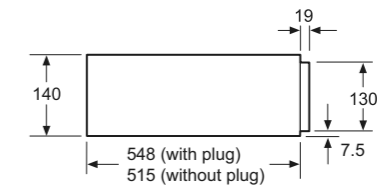
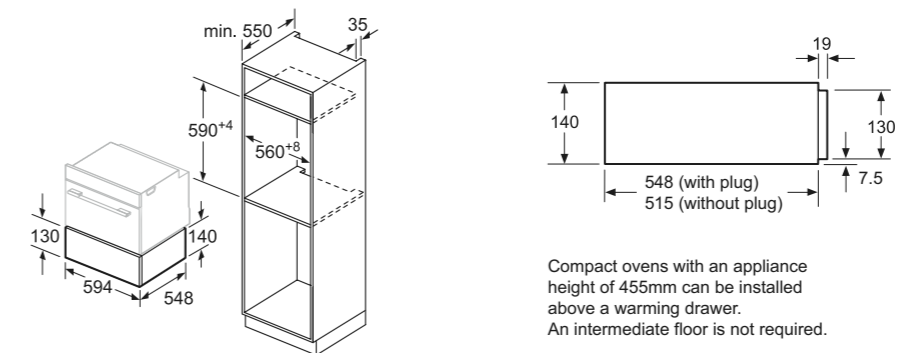

Compact ovens with an appliance height of 455mm can be installed above a warming drawer. An intermediate floor is not required.

Warming drawer BI510CNR0B

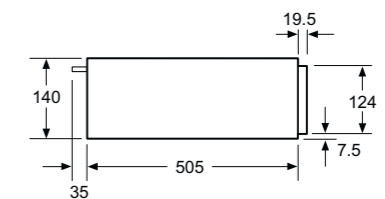
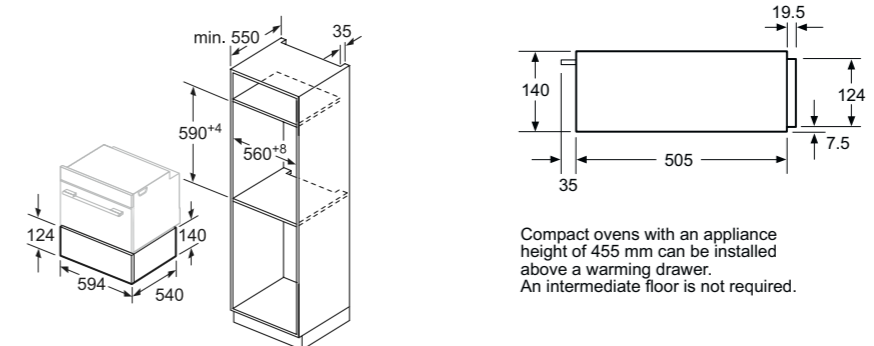

Compact ovens with an appliance height of 455 mm can be installed above a warming drawer. An intermediate floor is not required.

Coffee centre technical diagrams

Coffee centre CT636LES6

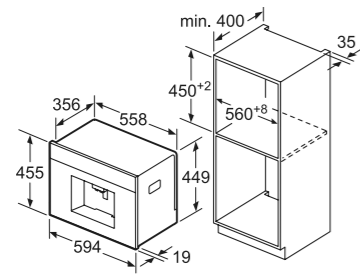

Bean and water containers are removed from the front. Recommended installation height 95-145cm.

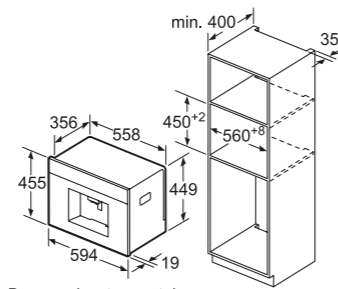

Bean and water containers are removed from the front. Recommended installation height 95-145cm.

left corner installation

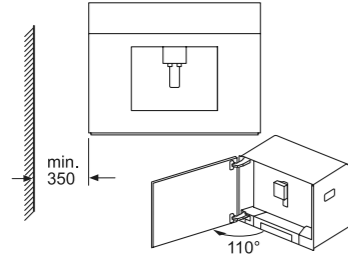

If using the 92° hinge limiter (spare part no. 00636455), the minimum distance to the wall is only 100mm.

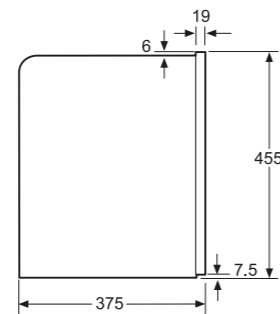

Hob technical diagrams

inductionAir Plus venting hobs ED851FQ15E and EH811BE15E

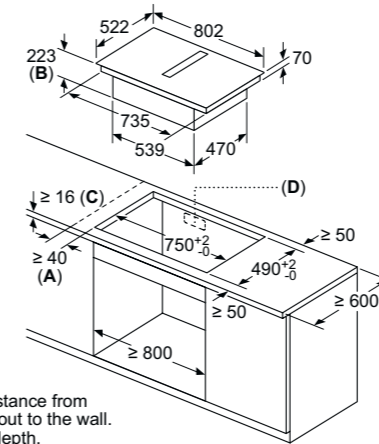

- A:** Minimum distance from the hob cut-out to the wall.
- B:** Recessing depth.
- C:** The worktop into which the hob is installed must withstand loads of approx. 60kg; suitable substructures must be used if required.
- D:** Cut-out in back panel required for pipework. Exact size and position can be taken from specific drawing.

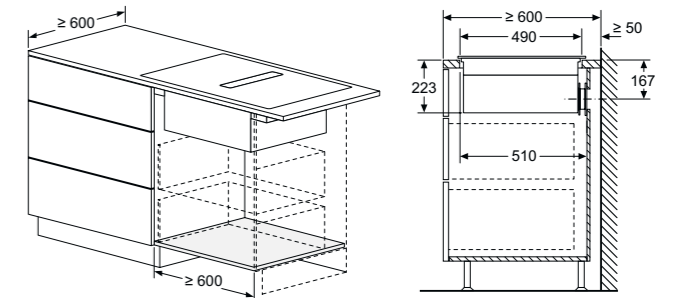

Ducted and unducted ventilation technical diagrams can be found online

inductionAir Plus venting hob ED711FQ15E

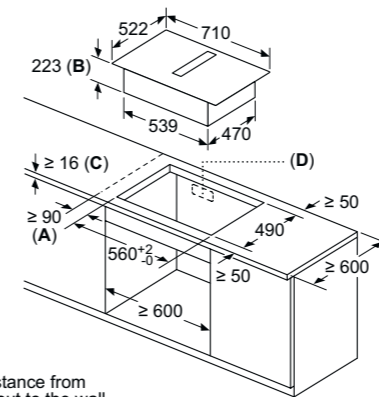

- A:** Minimum distance from the hob cut-out to the wall.
- B:** Recessing depth.
- C:** The worktop into which the hob is installed must withstand loads of approx. 60kg; suitable substructures must be used if required.
- D:** Cut-out in back panel required for pipework. Exact size and position can be taken from specific drawing.

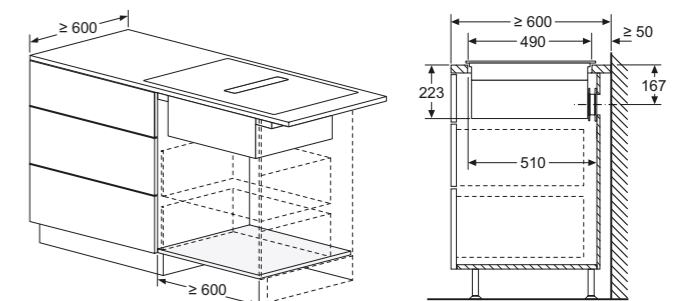

Ducted and unducted ventilation technical diagrams can be found online

Venting hob EH611BE15E

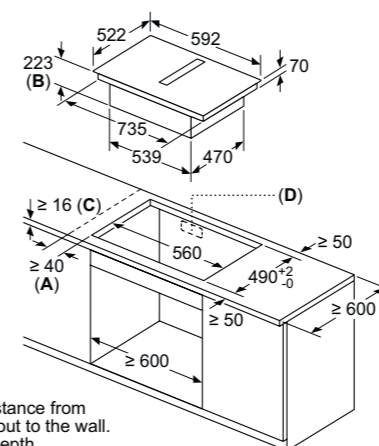

- A:** Minimum distance from the hob cut-out to the wall.
- B:** Recessing depth.
- C:** The worktop into which the hob is installed must withstand loads of approx. 60kg; suitable substructures must be used if required.
- D:** Cut-out in back panel required for pipework. Exact size and position can be taken from specific drawing.

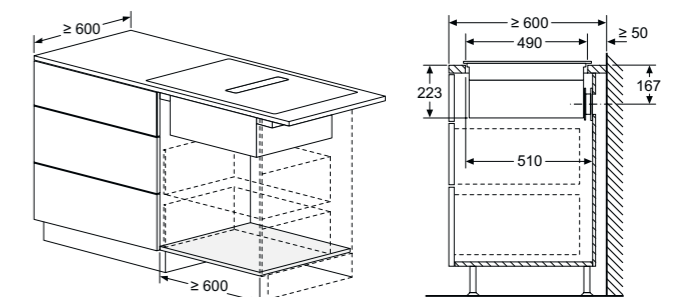

Ducted and unducted ventilation technical diagrams can be found online

Hob technical diagrams

flexInduction hobs EX975KXW1E and EX975LVV1E

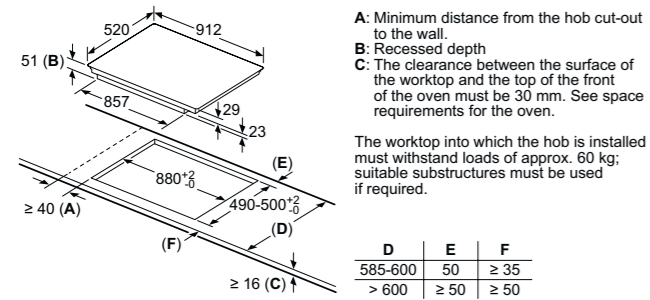

flexInduction hobs EX875KYV1E and EX879FVC1E

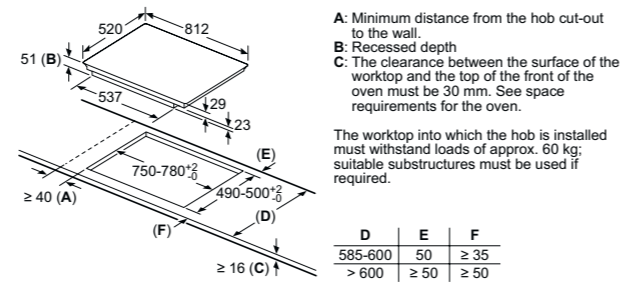

Induction hob EH801FVB1E

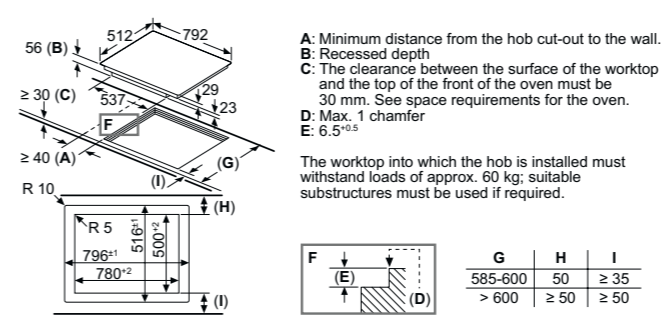

Induction hob EH601FEB1E

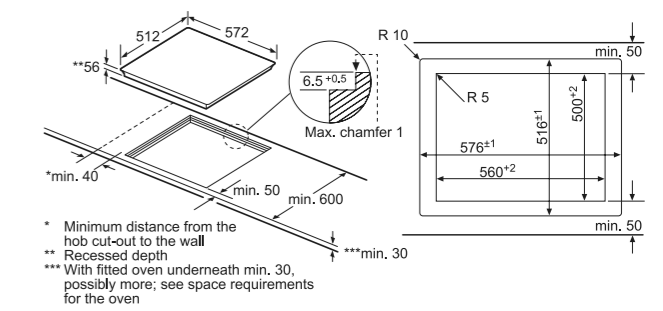

flexInduction hobs EX675LYV1E and EX675LXV1E

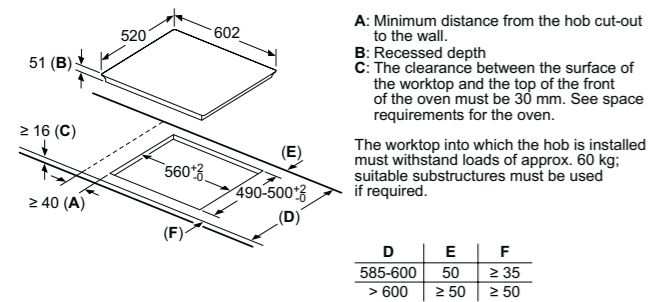

flexInduction hob EX275FXB1E

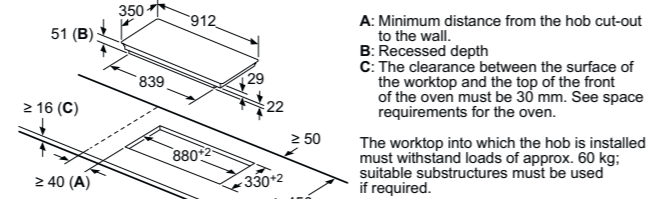

Induction hob EH845FVB1E

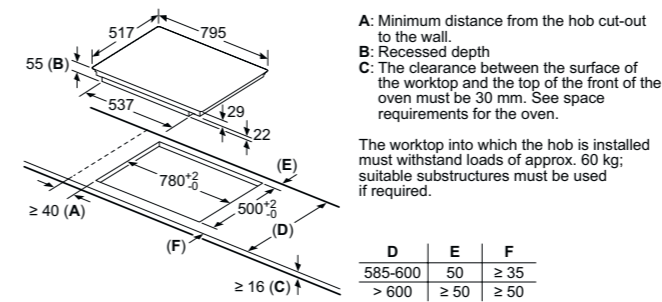

Induction hob EH645FEB1E

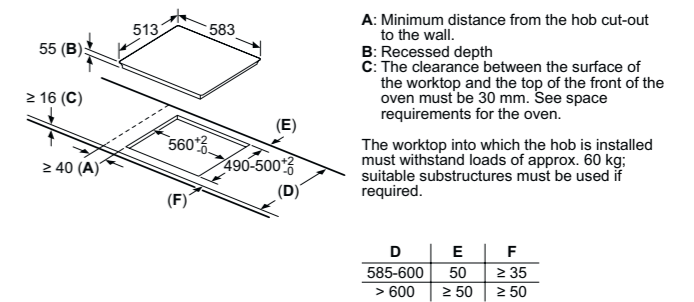

flexInduction and induction hobs EX851FVC1E and ED851FWB5E

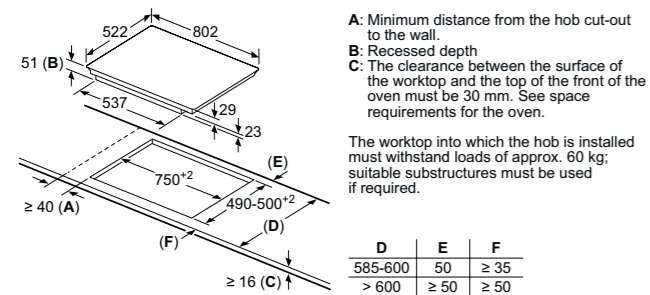

flexInduction and induction hobs EX651FEC1E, ED651FSB5E, EU631FEB1E, EU611BEB1E and EU631BEF1B

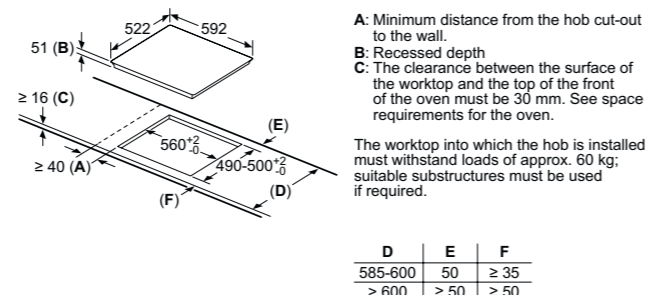

Induction hob EU61RAGA5B

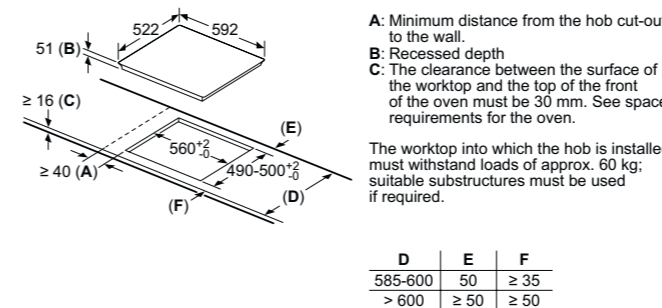

Hob technical diagrams

quickLite ceramic hob ET81RBHA1D

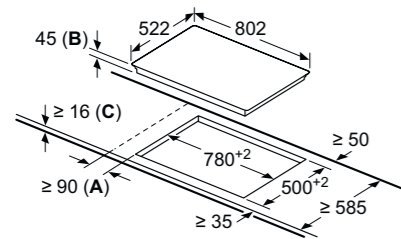

- A:** Minimum distance from the hob cut-out to the wall.
- B:** Recessed depth
- C:** With fitted oven underneath min. 20, possibly more; see space requirements for the oven.

quickLite hob ET61RBEA1E

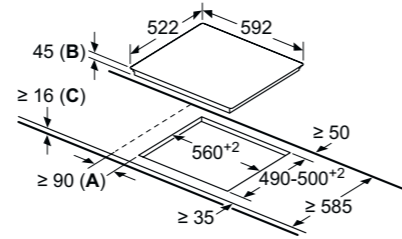

- A:** Minimum distance from the hob cut-out to the wall.
- B:** Recessed depth
- C:** With fitted oven underneath min. 20, possibly more; see space requirements for the oven.

quickLite ceramic hob ET61RCEA1E

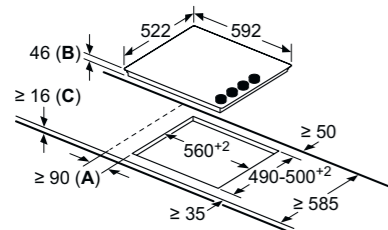

- A:** Minimum distance from the hob cut-out to the wall.
- B:** Recessed depth
- C:** With fitted oven underneath min. 20, possibly more; see space requirements for the oven.

Gas hob ER9A6SB70

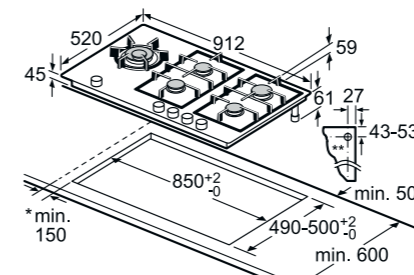

- * Minimum distance from the hob cut-out to the wall
- ** Position of gas connection in the cut-out
- *** With fitted oven underneath, possibly more; see space requirements for the oven

Gas hob EP9A6SB90

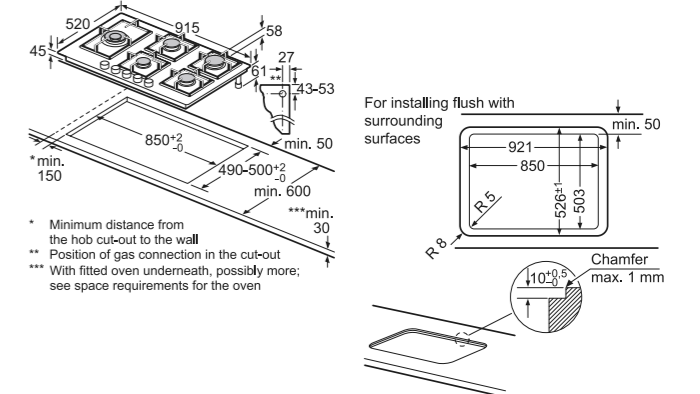

- * Minimum distance from the hob cut-out to the wall
- ** Position of gas connection in the cut-out
- *** With fitted oven underneath, possibly more; see space requirements for the oven

Gas hob EP7A6QB90

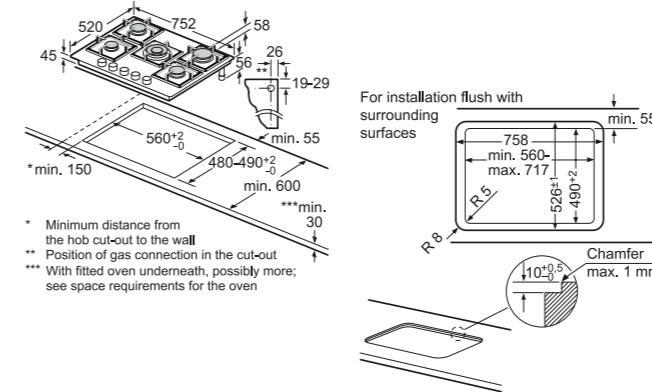

- * Minimum distance from the hob cut-out to the wall
- ** Position of gas connection in the cut-out
- *** With fitted oven underneath, possibly more; see space requirements for the oven

Gas hob EP6A6HB20

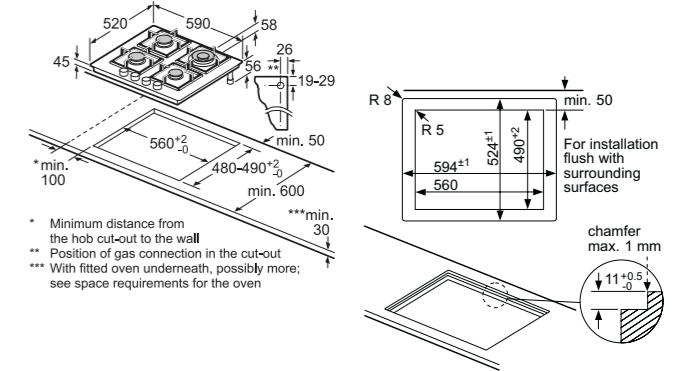

- * Minimum distance from the hob cut-out to the wall
- ** Position of gas connection in the cut-out
- *** With fitted oven underneath, possibly more; see space requirements for the oven

For all flexInduction, induction and quickLite ceramic hobs

Below are diagrams for installation applicable to all flexInduction, induction and quickLite ceramic hobs

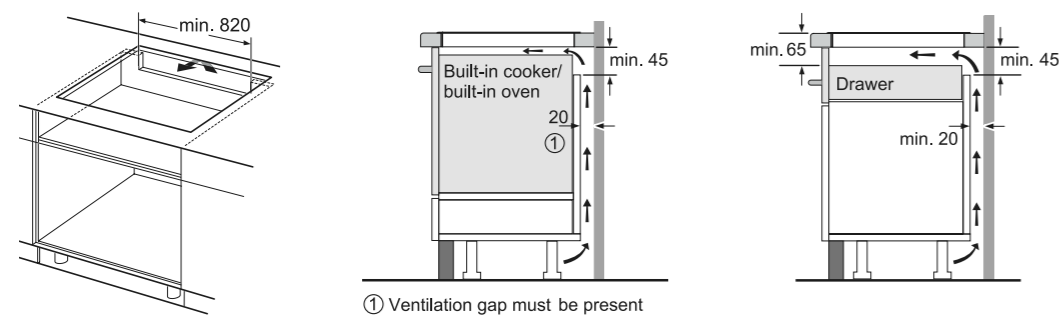

Gas hob EC9A5SB90

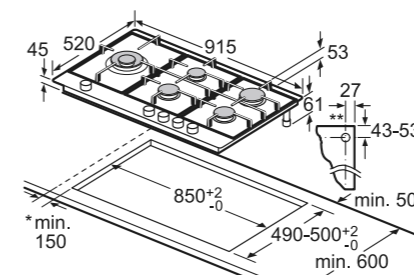

- * Minimum distance from the hob cut-out to the wall
- ** Position of gas connection in the cut-out
- *** With fitted oven underneath, possibly more; see space requirements for the oven

Gas hobs EC7A5RB90 and EG7B5QB90

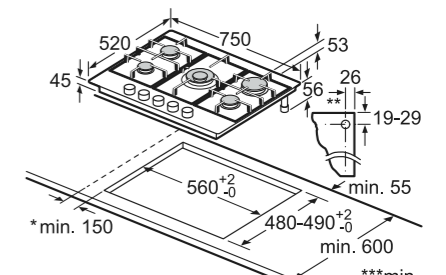

- * Minimum distance from the hob cut-out to the wall
- ** Position of gas connection in the cut-out
- *** With fitted oven underneath, possibly more; see space requirements for the oven

Hob technical diagrams

Gas hobs EC6A5HC90 and EC6A5PB90

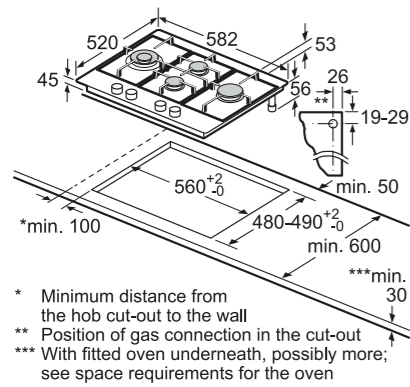

Gas hob EB6B5PB60

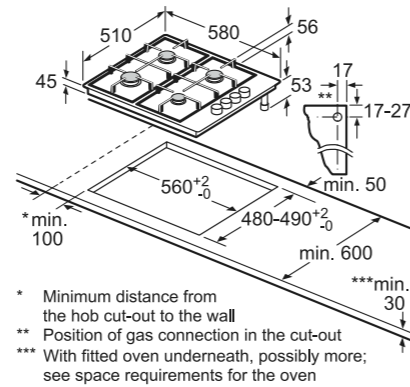

Domino hob combination installation

Below are diagrams showing the possible combinations for installing your Domino hob

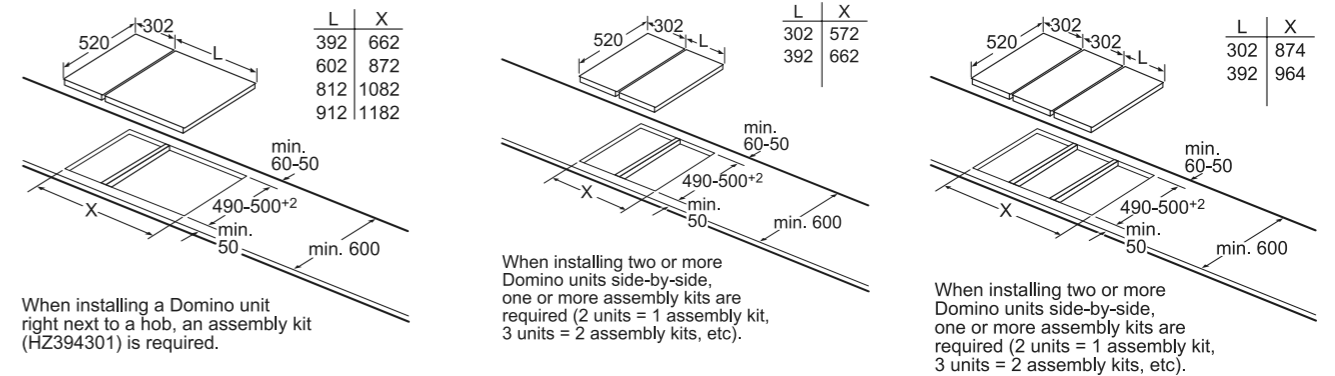

Teppan yaki domino hob ET475FYB1E

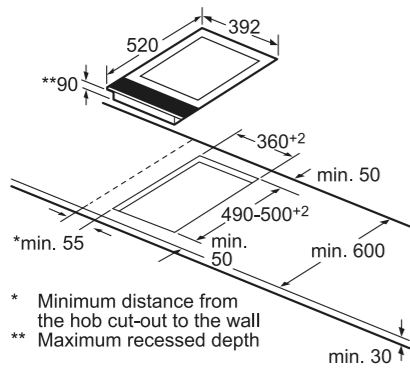

flexInduction domino hob EX375FXB1E

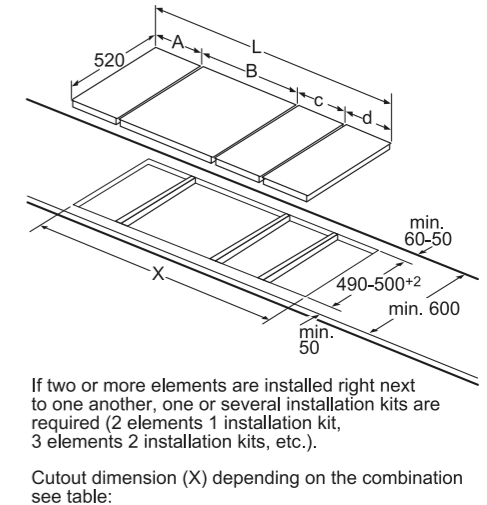
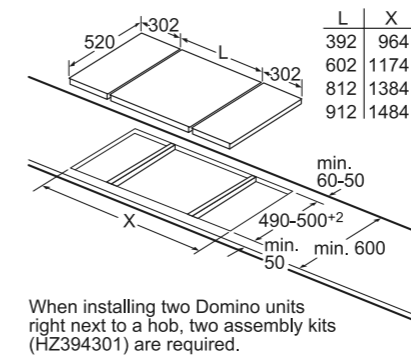
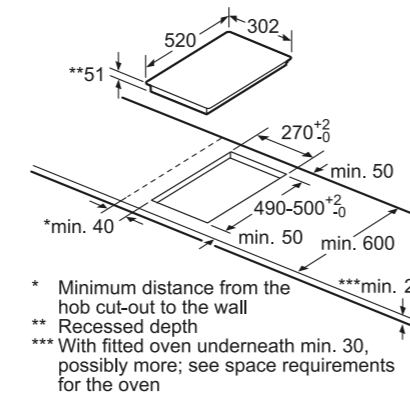

Wok domino gas hob ER3A6AB70

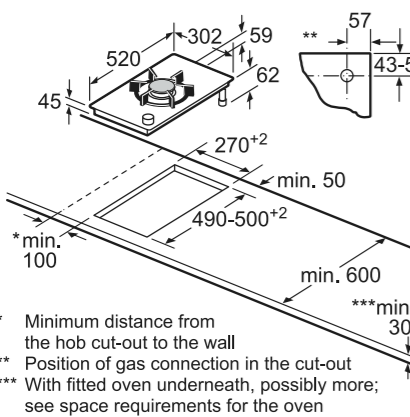

Domino gas hob ER3A6BB70

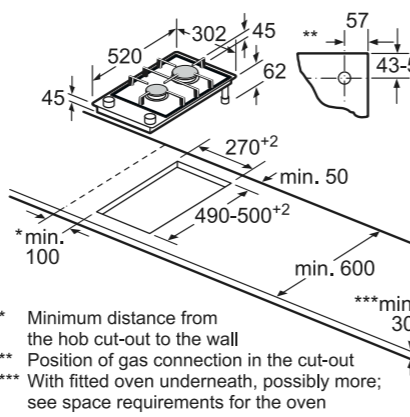

Domino combination possibilities with corresponding device and cutout dimensions

Width type: 30 40 60 70 80 90
Device width: 302 392 602 710 812 912

	A	B	C	D	L	X
2x30	302	302	-	-	604	572
1x30, 1x40	302	392	-	-	694	662
1x30, 1x60	302	602	-	-	904	872
1x30, 1x70	302	710	-	-	1012	980
1x30, 1x80	302	812	-	-	1114	1082
1x30, 1x90	302	912	-	-	1214	1182
2x40	392	392	-	-	784	752
1x40, 1x60	392	602	-	-	994	962
1x40, 1x70	392	710	-	-	1102	1070
1x40, 1x80	392	812	-	-	1204	1172
1x40, 1x90	392	912	-	-	1304	1272
3x30	302	302	302	-	906	874
2x30, 1x40	302	302	392	-	996	964
2x30, 1x60	302	302	602	-	1206	1174
2x30, 1x70	302	302	710	-	1314	1282
2x30, 1x80	302	302	812	-	1416	1384
2x30, 1x90	302	302	912	-	1516	1484
1x30, 2x40	302	392	392	-	1086	1054
1x30, 1x40, 1x60	302	392	602	-	1296	1264
1x30, 1x40, 1x70	302	392	710	-	1404	1372
1x30, 1x40, 1x80	302	392	812	-	1506	1474
1x30, 1x40, 1x90	302	392	912	-	1606	1574
3x40	392	392	392	-	1176	1144
2x40, 1x60	392	392	602	-	1386	1354
4x30	302	302	302	302	1208	1176
3x30, 1x40	302	302	302	392	1298	1266
2x30, 2x40	302	302	392	392	1388	1356
1x30, 3x40	302	392	392	392	1478	1446

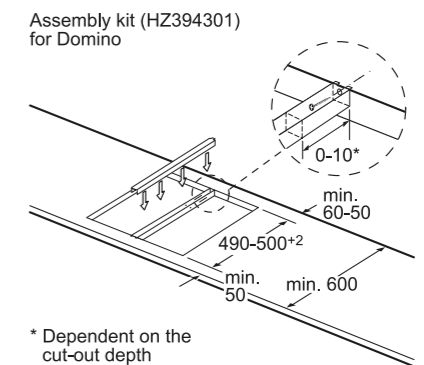

Hood technical diagrams

Ceiling hood LR96CAQ50B

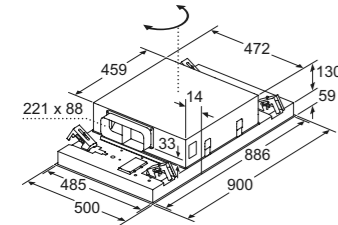

The fan outlet can be turned in all four directions

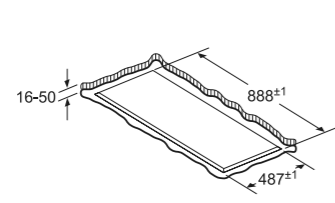

Never fit directly onto plasterboard or similar lightweight construction materials of the suspended ceiling. A suitable substructure is required that is securely fixed to the concrete ceiling.

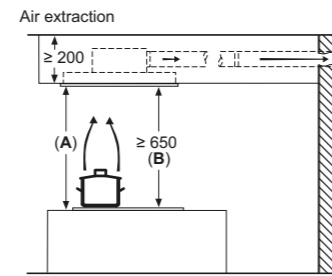

A: Optimum performance 700-1500
B: From upper edge of pan support

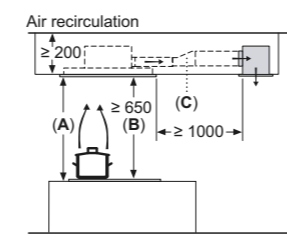

A: Optimum performance 700-1500
B: From upper edge of pan support
C: Connector (from a flat duct to a circular duct). Not included in the scope of delivery.

Ceiling hood LR97CAQ50B

The fan outlet can be turned in all four directions

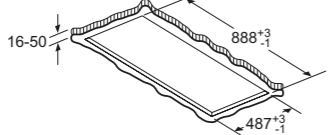
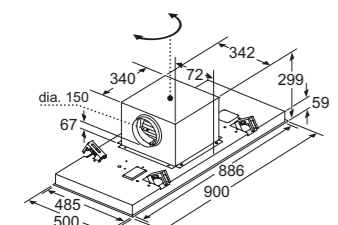

Never fit directly onto plasterboard or similar lightweight construction materials of the suspended ceiling. A suitable substructure is required that is securely fixed to the concrete ceiling.

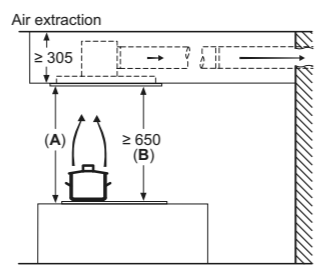

A: Optimum performance 700-1500
B: From upper edge of pan support

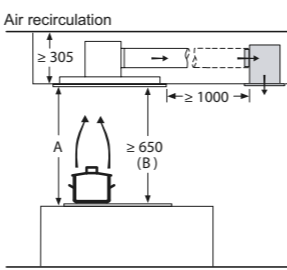

A: Optimum performance 700-1500
B: From upper edge of pan support

Ceiling hood LR97CAP21B

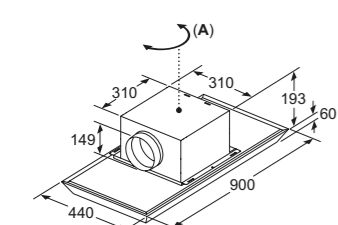

A: The fan outlet can be turned in all four directions

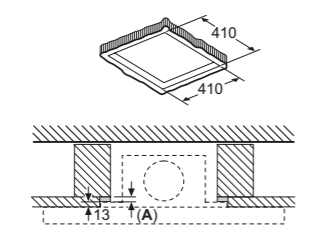

A: If required, even out the ceiling thickness to 13 mm using wooden spacers.

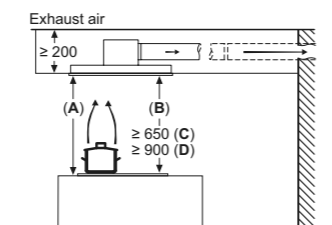

A: Optimum performance 700-1500
B: From upper edge of pan support
C: Electric
D: Gas

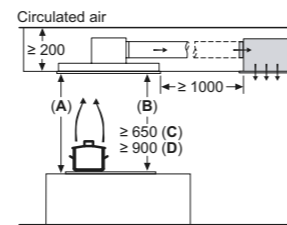

A: Optimum performance 700-1500
B: From upper edge of pan support
C: Electric
D: Gas

glassdraftAir hood LD98WMM60B

Technical diagrams for seamless installation can be found online at siemens-home.bsh-group.com/uk

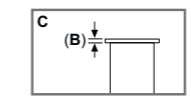
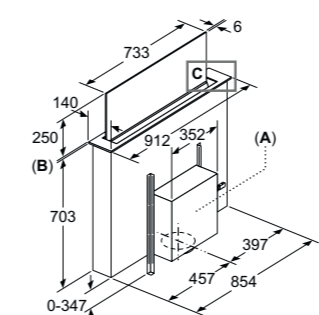

A: Installation of motor unit on front/rear or offset laterally with max. 3 m clearance (special accessory required)

Motor unit must always be accessible

B: 5.5 mm

Planning recommendation, air recirculation

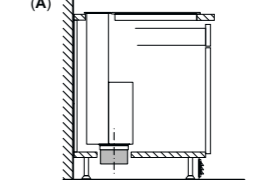

A: Exterior wall – U-value ≤ 0.5 W/(m²K)

Standard installation: Partially laid around the toe kick

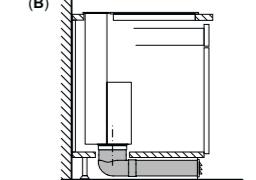

B: Exterior wall – U-value > 0.5 W/(m²K)

Installation with fully laid pipework to the toe kick for poorly insulated exterior walls or above cold floors

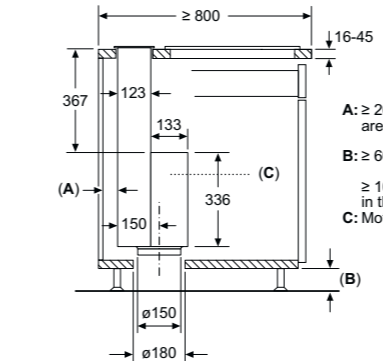

A: ≥ 20 mm between the Guided Air suction area and a cabinet wall
B: ≥ 60 mm for air recirculation
≥ 100 mm for air extraction with ducting in the plinth
C: Motor unit must always be accessible

Combination with electric hob

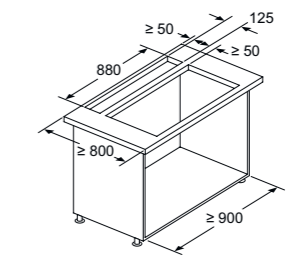

Combination with gas hob is not possible

To prevent power loss, observe the following:

- Do not install upper cabinets above the appliance
- Clearance of open shelf elements above the appliance min. 650 mm (recommended)
- Left/right clearance between appliance and wall/adjacent upper cabinet min. 500 mm
- Clearance between appliance frame and wall min. 50 mm

Island chimney hood LF91BUV50B

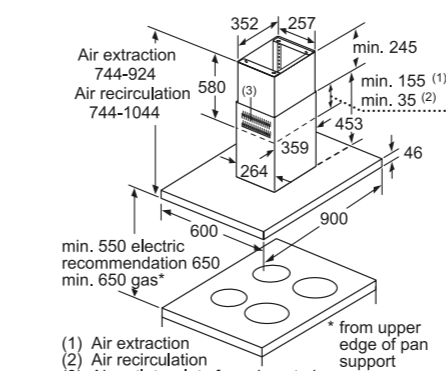

- (1) Air extraction 744-924
- (2) Air recirculation 744-1044
- (3) Air outlet – slots for exhaust air to be mounted facing down

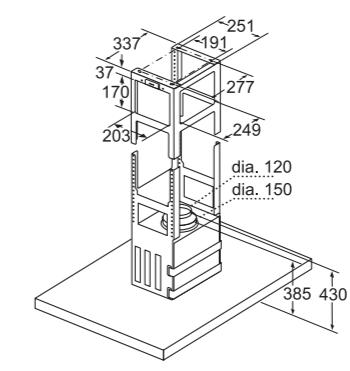

height-adjustable in 20 mm increments (744-1044)

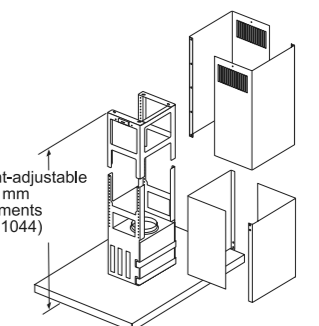

Island chimney hood LF97GBM50B

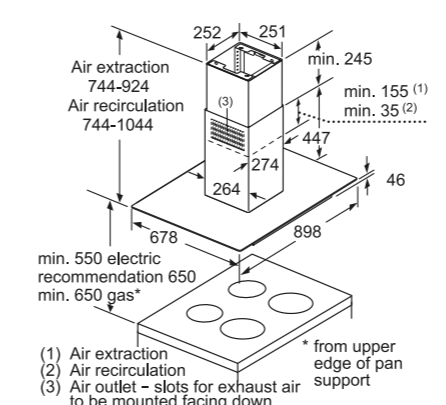

- (1) Air extraction 744-924
- (2) Air recirculation 744-1044
- (3) Air outlet – slots for exhaust air to be mounted facing down

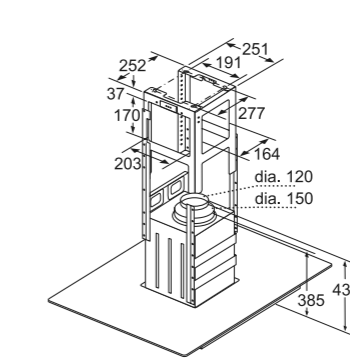

height-adjustable in 20 mm increments (744-1044)

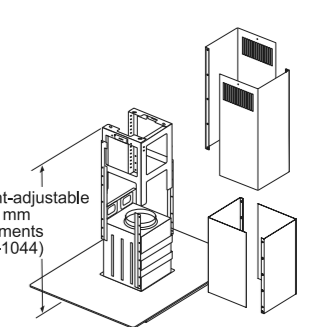

Hood technical diagrams

Angled chimney hood LC91KWW60B

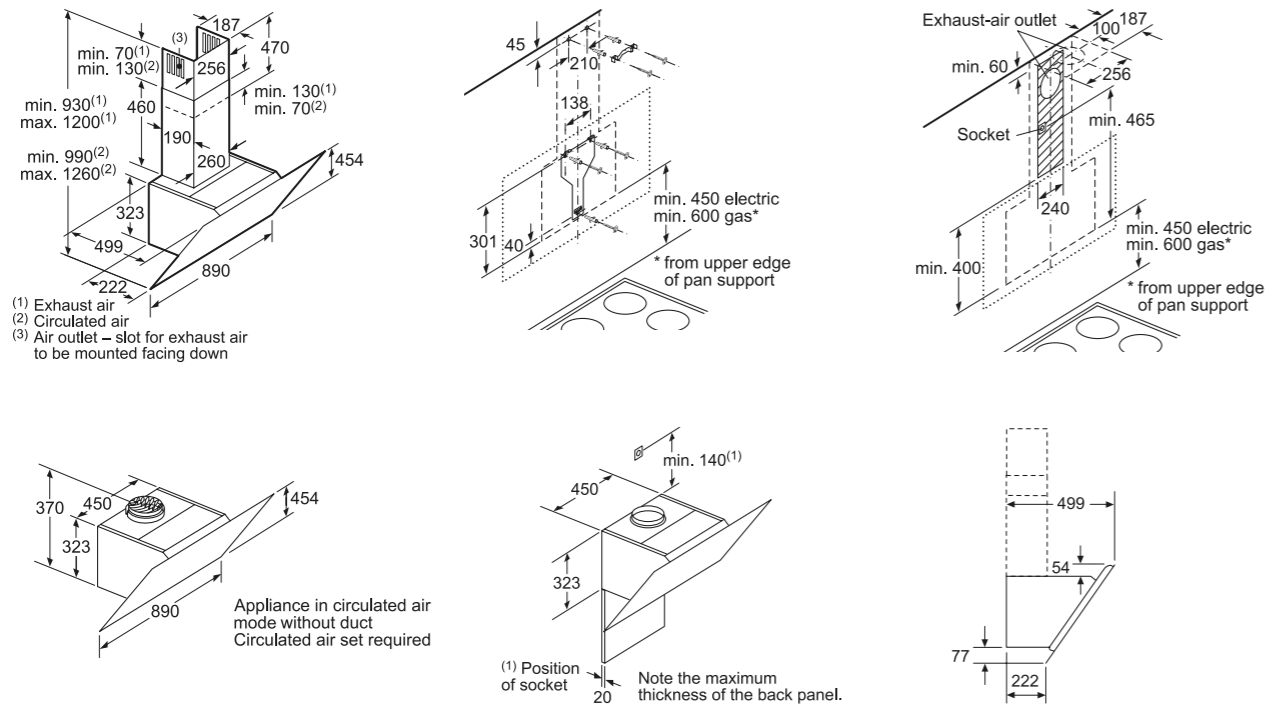

Box chimney hood LC91BUV50B

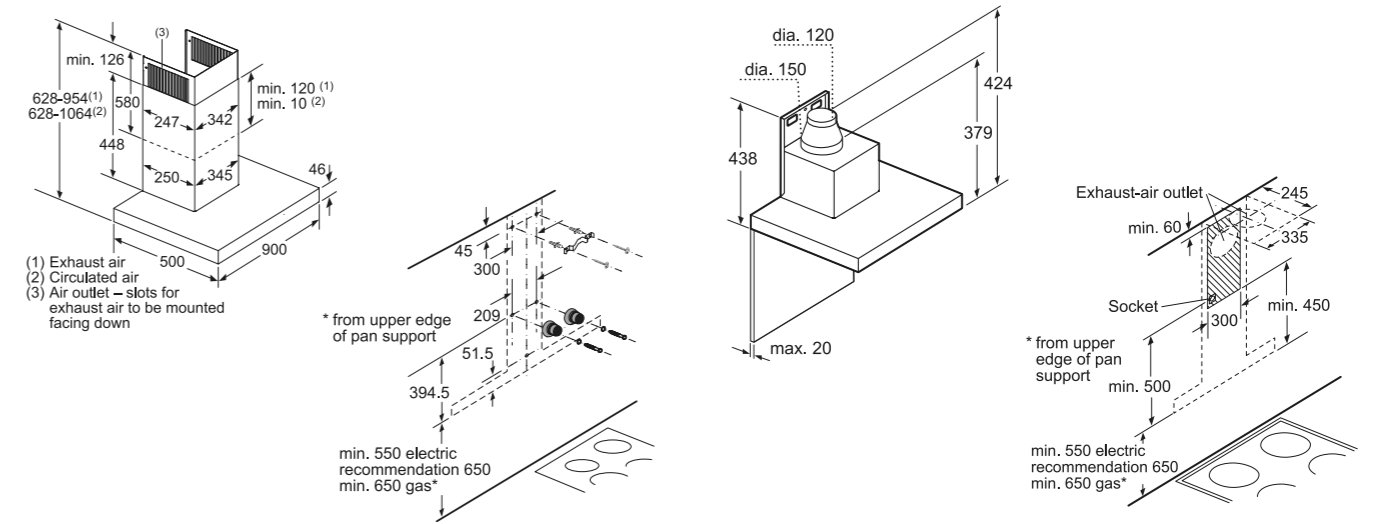

Box chimney hoods LC97BHM50B, LC77BHM50B and LC67BHM50B

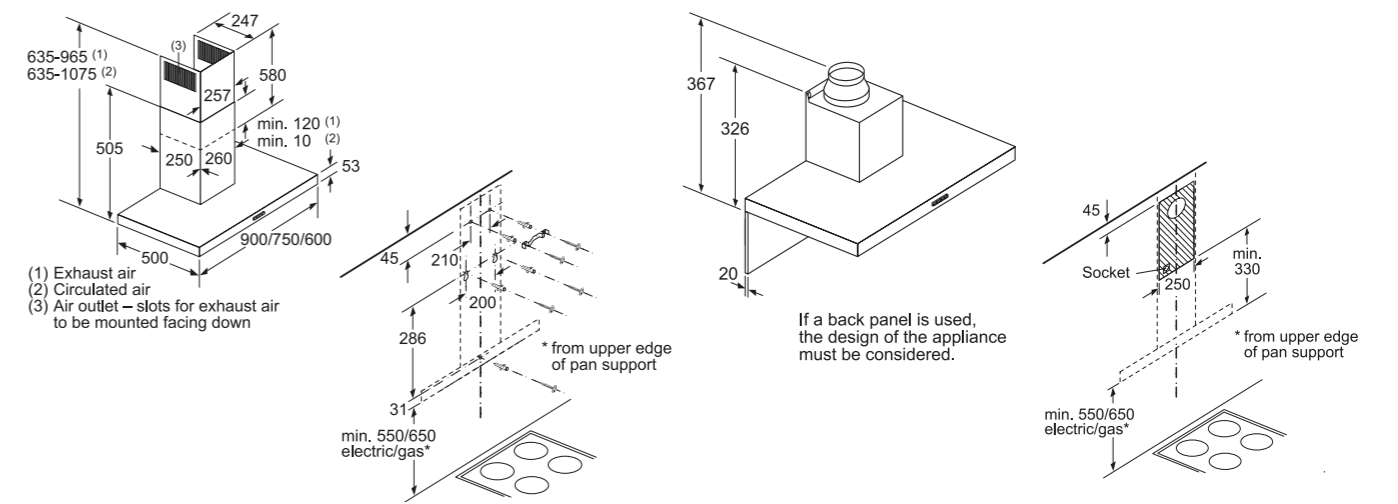

Angled chimney hoods LC87KHM60B and LC67KHM60B

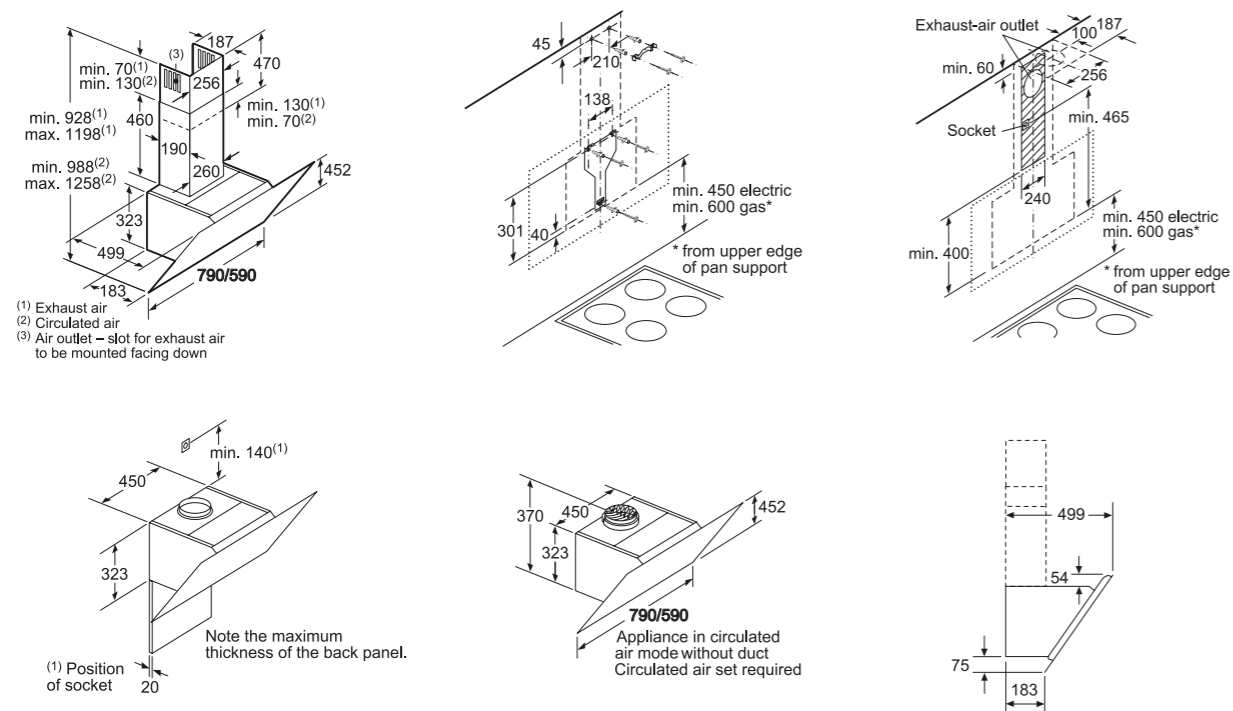

Box chimney hoods LC94BBC50B and LC64BBC50B

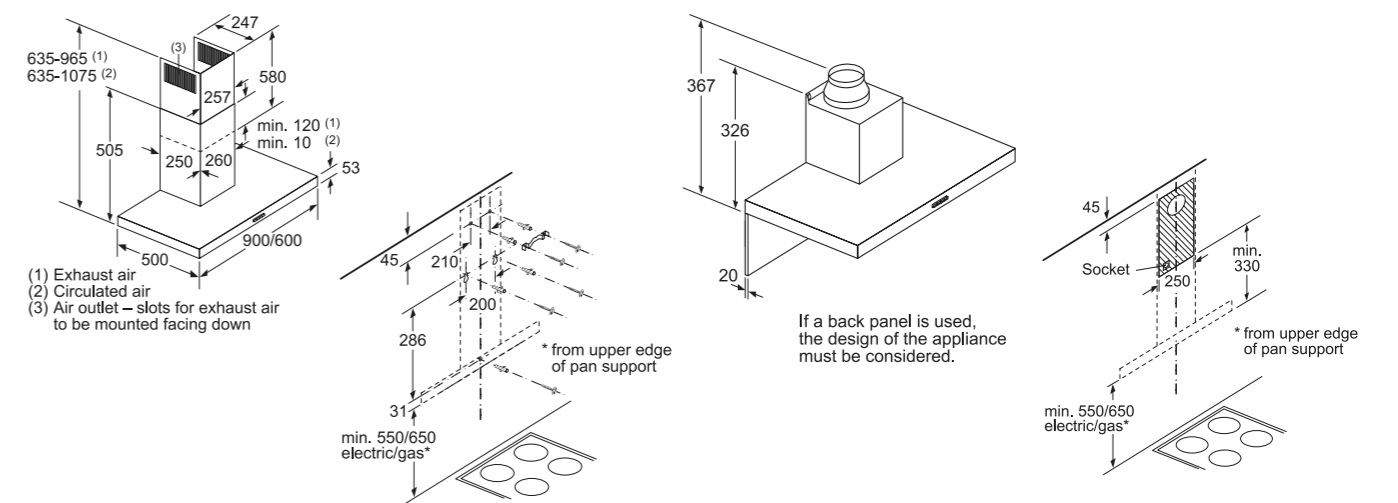

Hood technical diagrams

Curved glass chimney hoods LC97AFM50B and LC67AFM50B

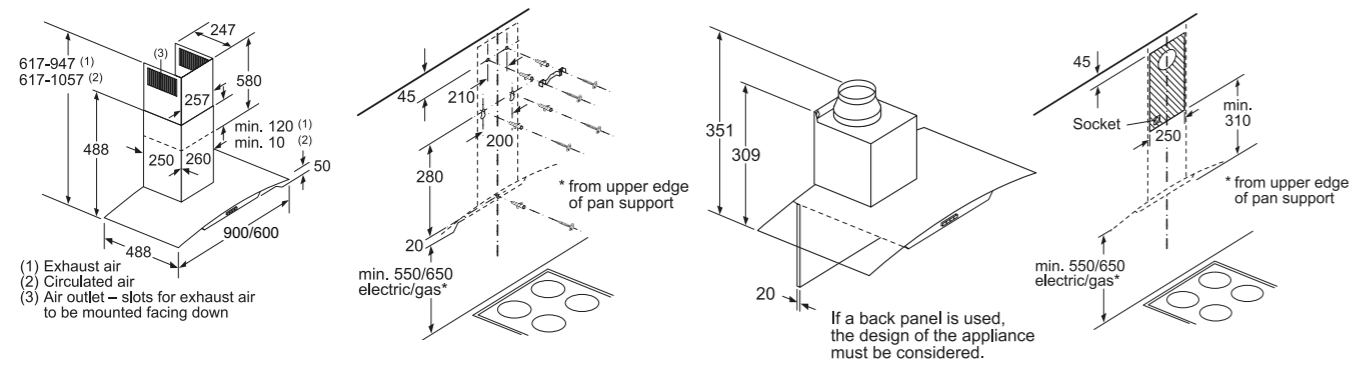

Slim pyramid chimney hoods LC97QFM50B and LC67QFM50B

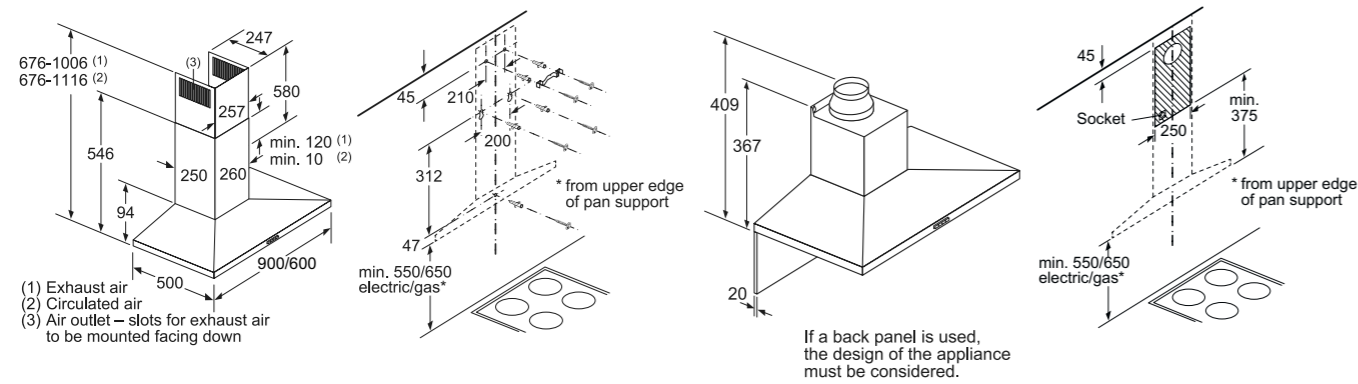

Pyramid chimney hoods LC94PBC50B and LC64PBC50B

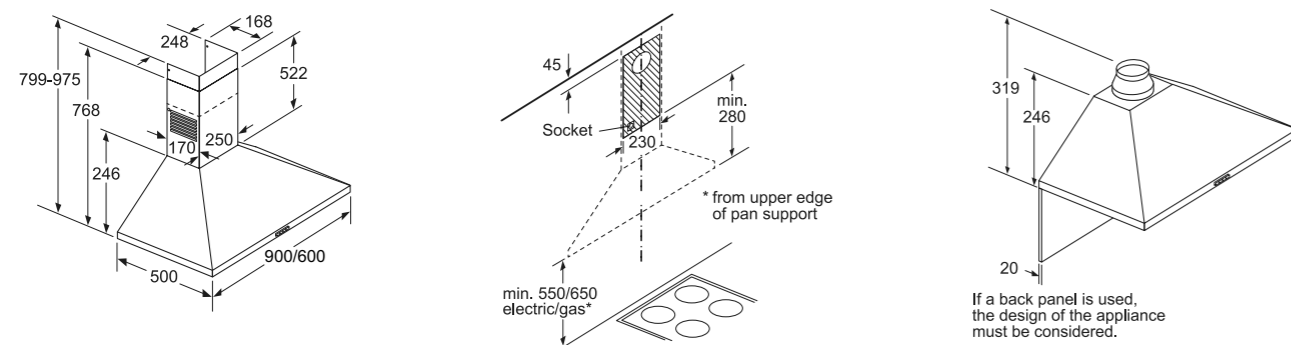

Integrated design hood LJ97BAM60B

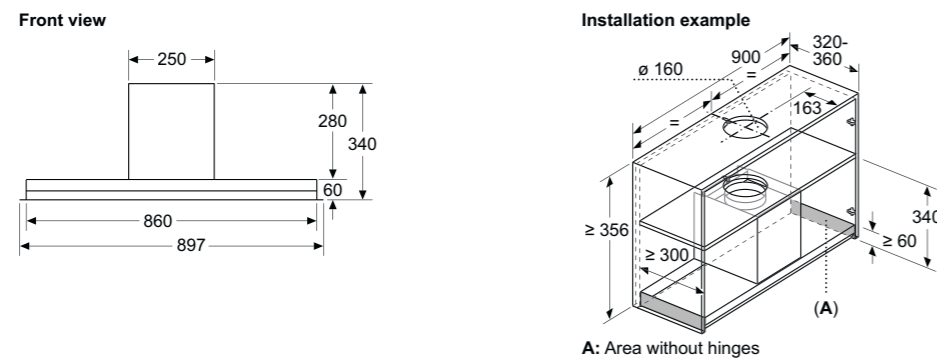

Integrated design hood LJ67BAM60B

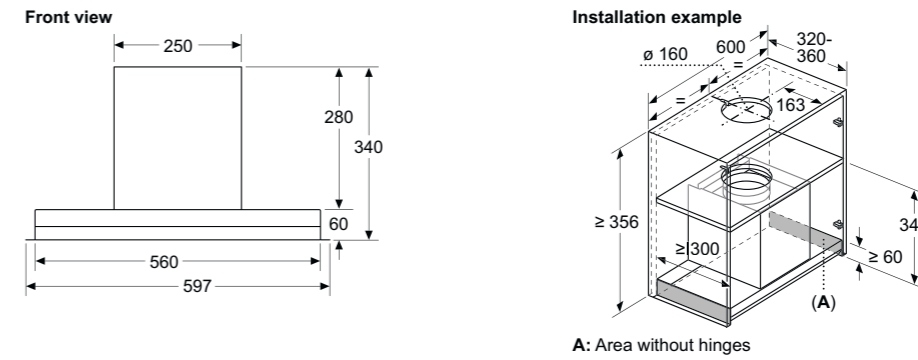

Telescopic hood LI97SA561B

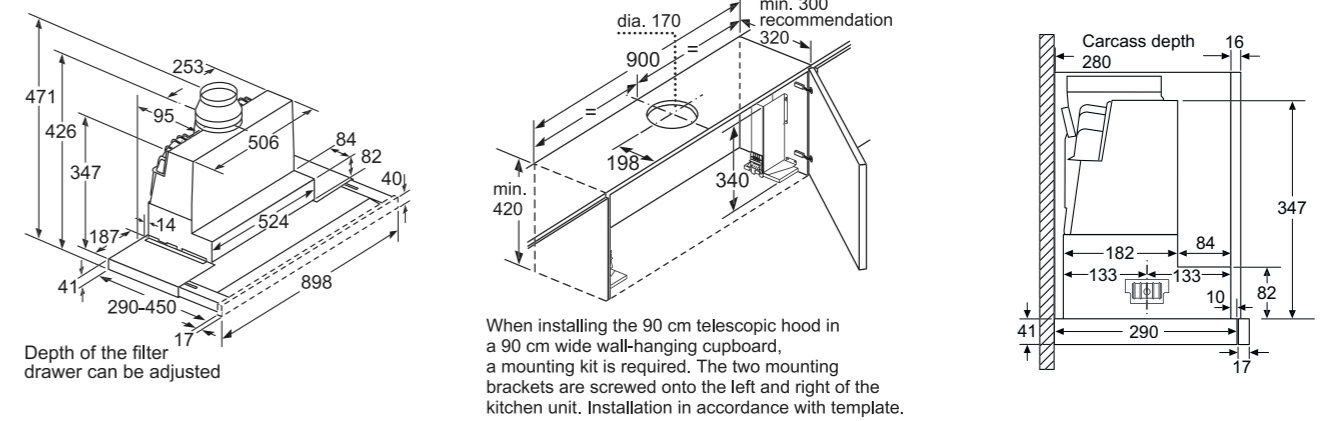

Telescopic hood LI94MA531B

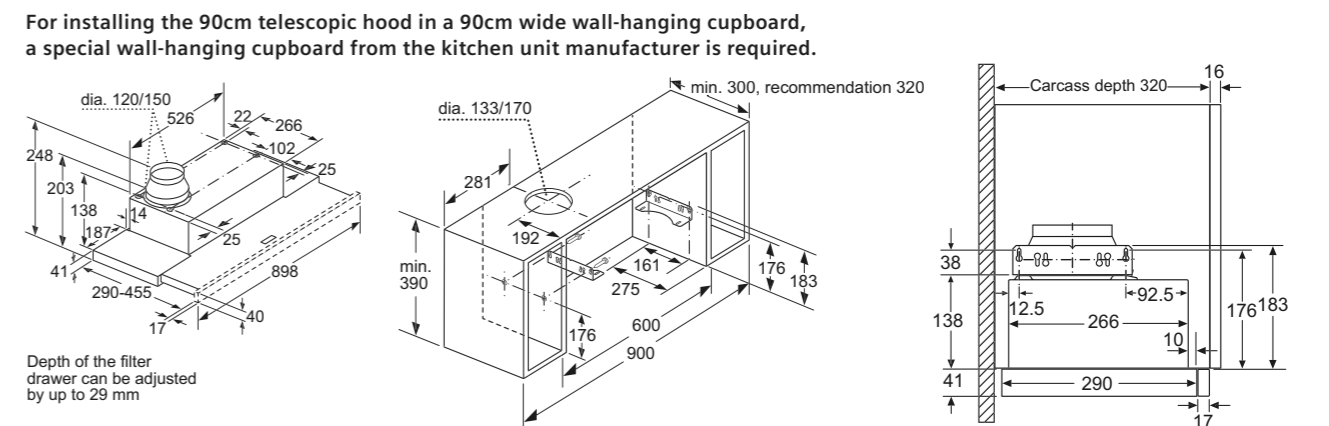

Telescopic hood LI64MA531B

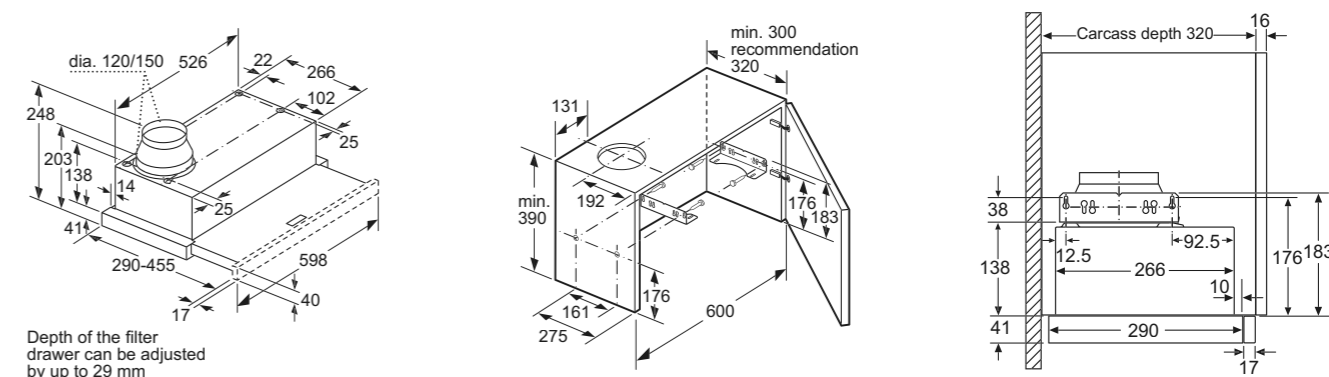

Hood technical diagrams

Integrated hoods LE66MAC00B and LE63MAC00B

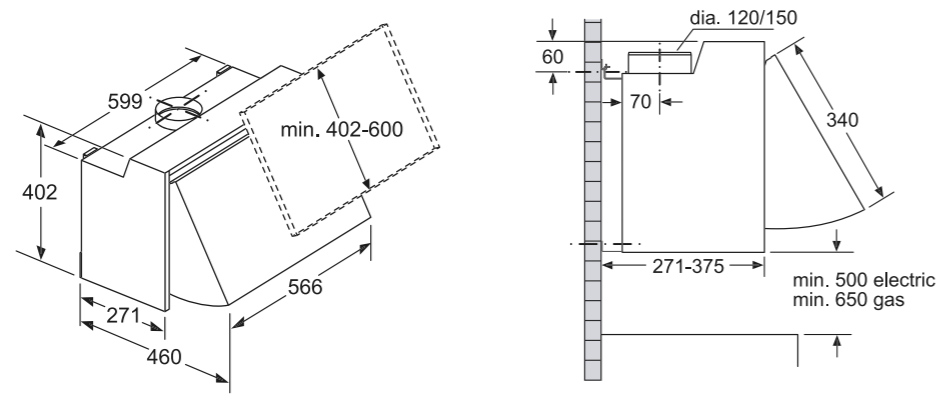

Canopy hoods LB79585MGB and LB78574GB

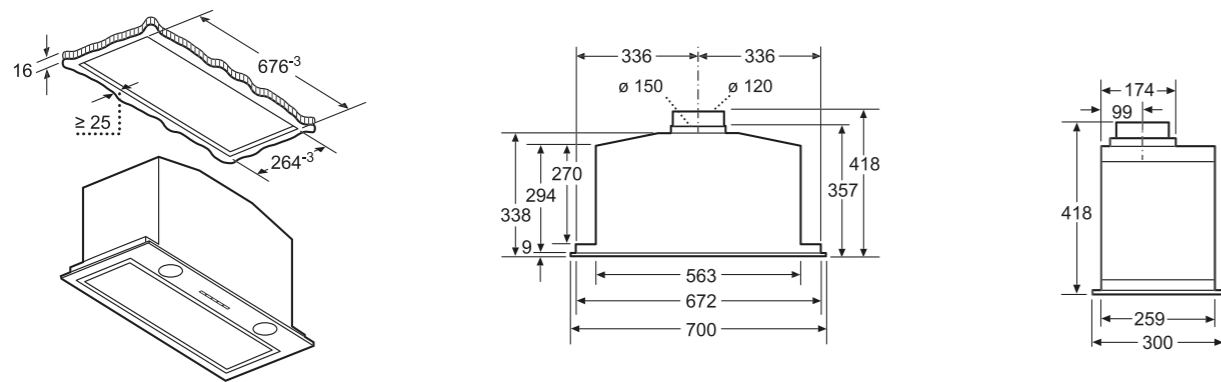

Canopy hood LB57574GB

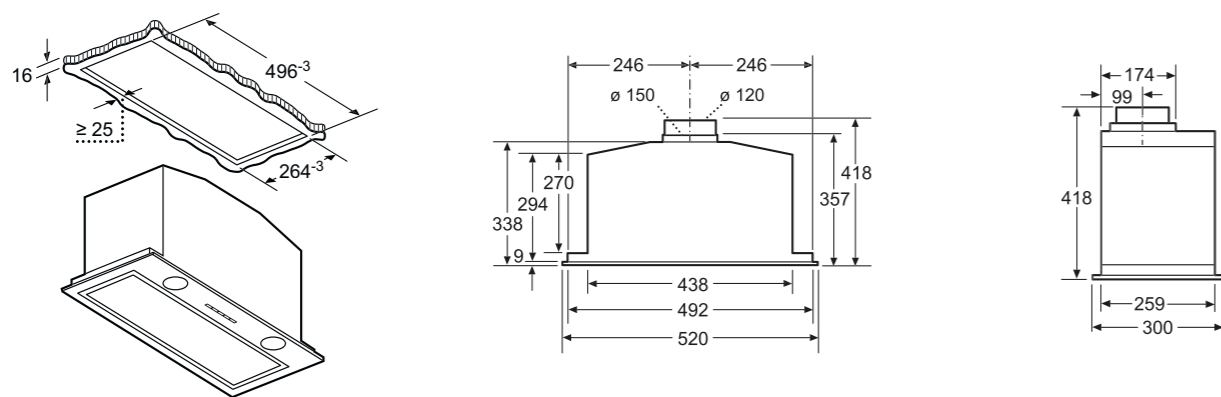

Canopy hood LB75565GB

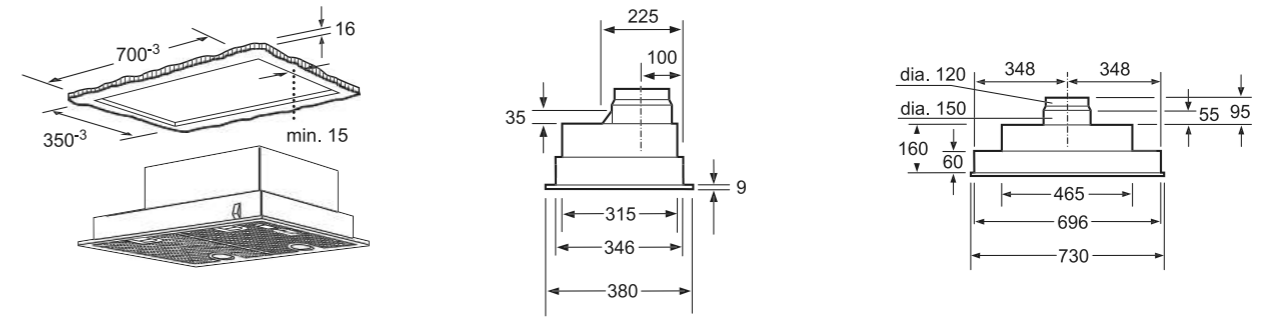

Canopy hood LB55565GB

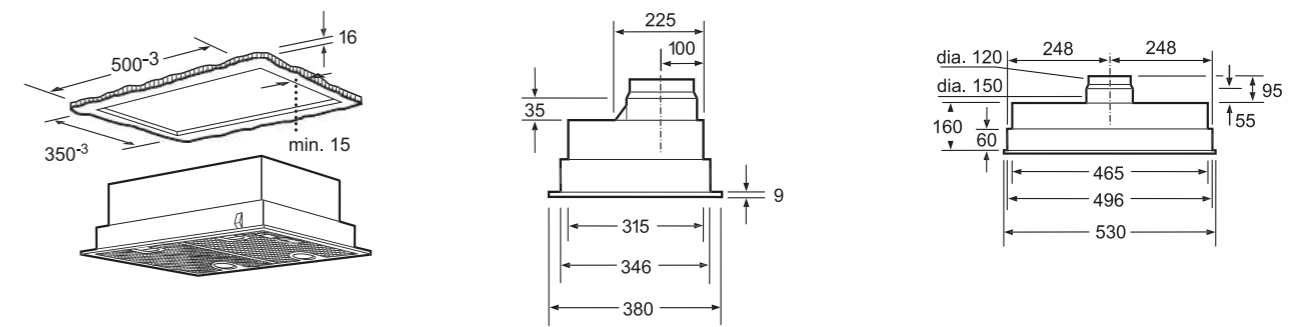

Canopy hood LB53NAA30B

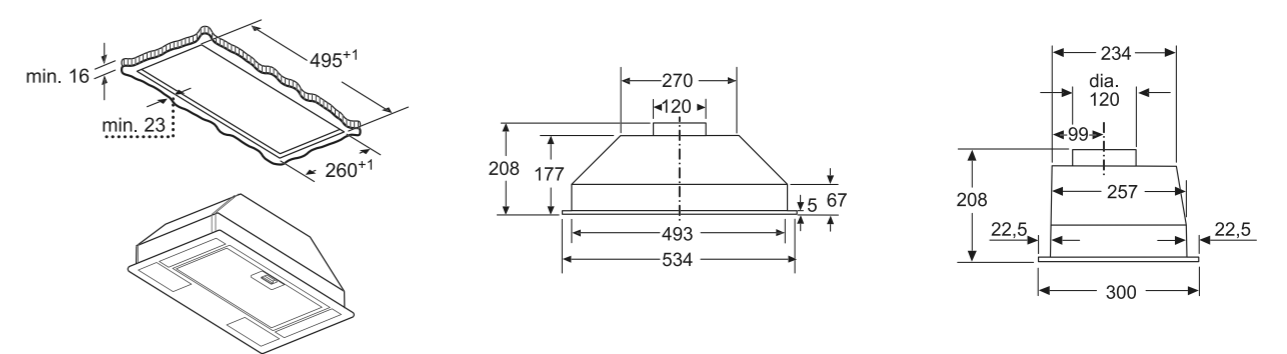

Cooling technical diagrams

Wine cabinet KU20WVHF0G

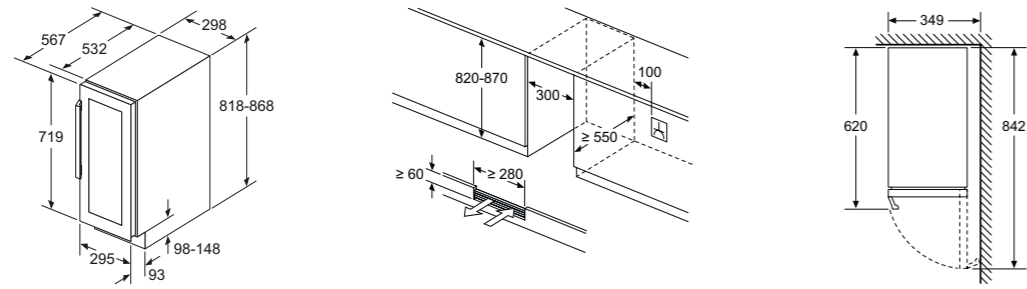

Wine cabinet KU21WAHG0G

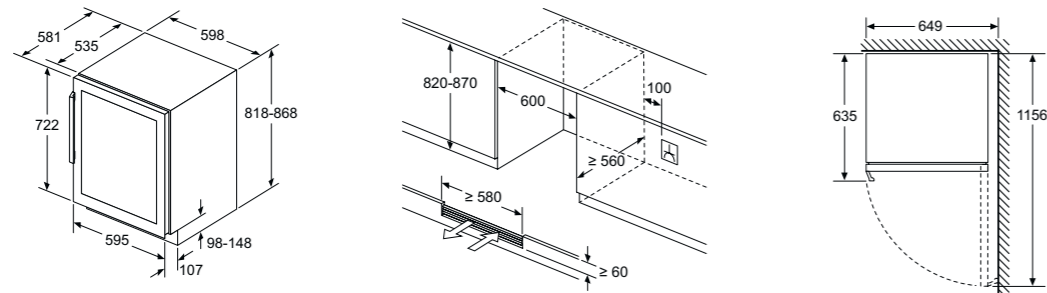

Multi Door / American Style fridge freezer KF96RSBEA

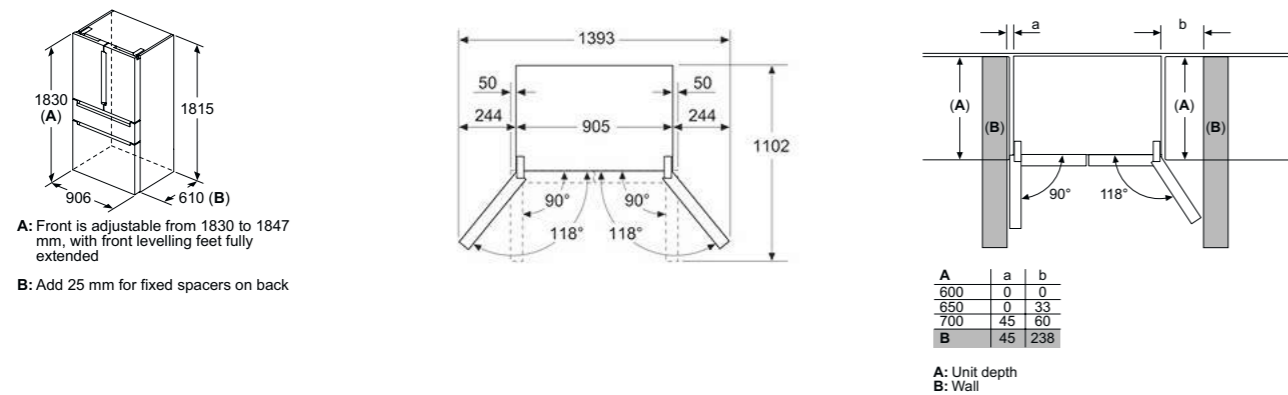

American Style fridge freezers KF96NAXEAG and KF96NVPEAG

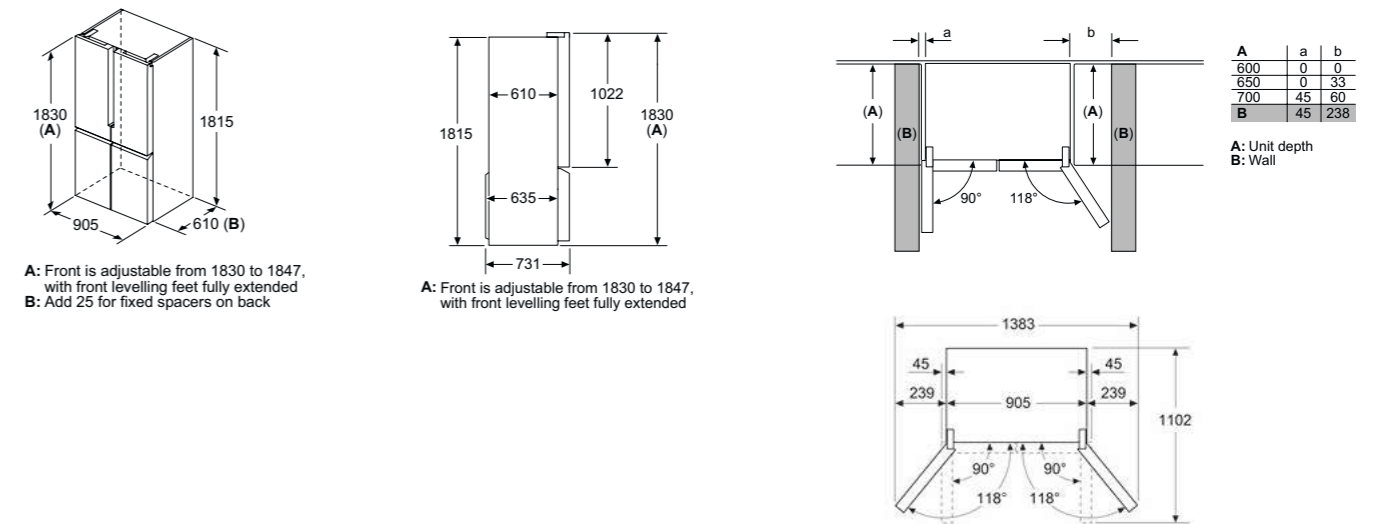

American Style fridge freezers KA93DVIFPG and KA93IVIFPG

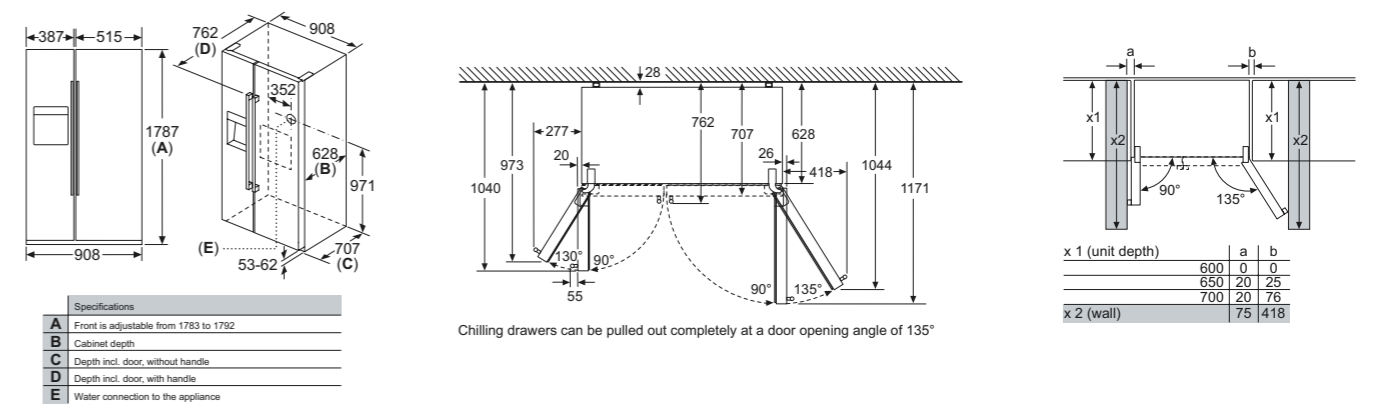

American Style fridge freezer KA93NVIFP

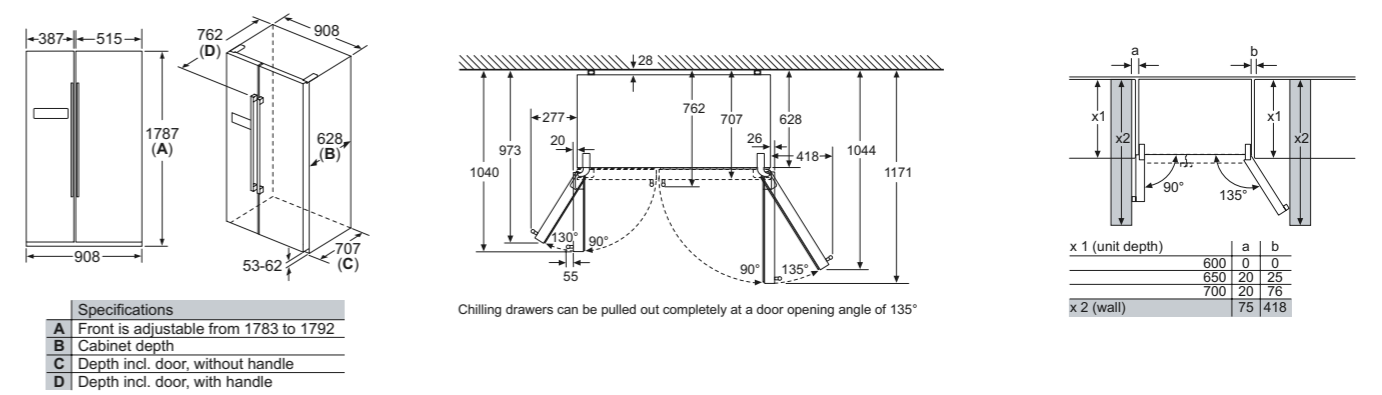

Cooling technical diagrams

noFrost bottom fridge freezer KI86NADF0

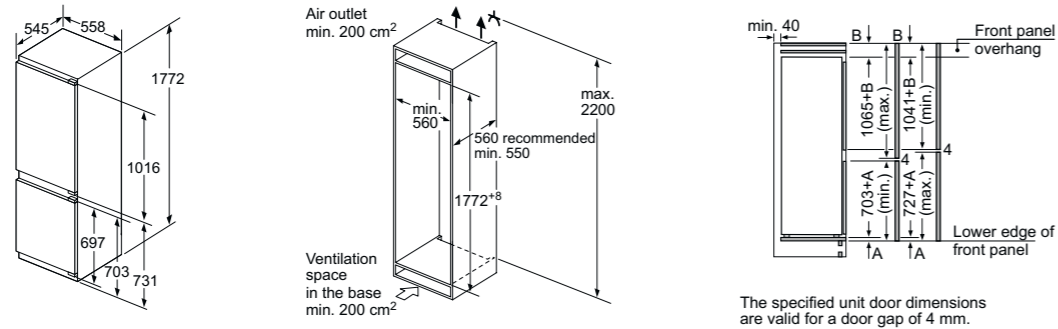

The specified unit door dimensions are valid for a door gap of 4 mm.

lowFrost bottom fridge freezer KI86SAFE0G

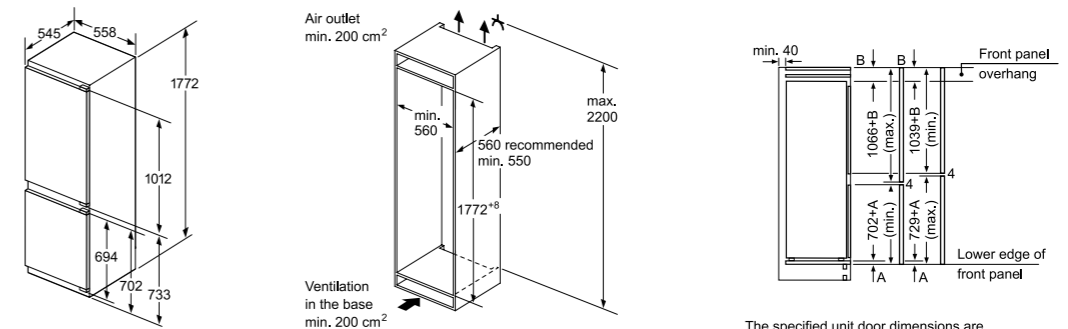

The specified unit door dimensions are valid for a door gap of 4 mm.

noFrost bottom fridge freezers KI86NHFE0 and KI86NVFE0G

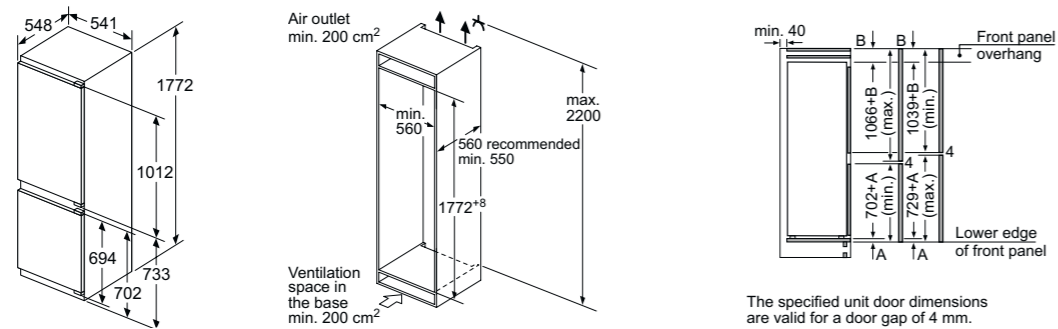

The specified unit door dimensions are valid for a door gap of 4 mm.

lowFrost bottom fridge freezer KI86VVE0G

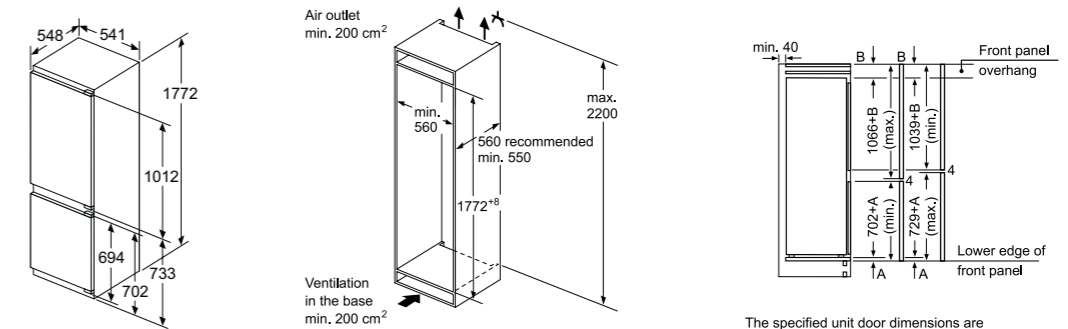

The specified unit door dimensions are valid for a door gap of 4 mm.

lowFrost bottom fridge freezer KI87SAFE0G

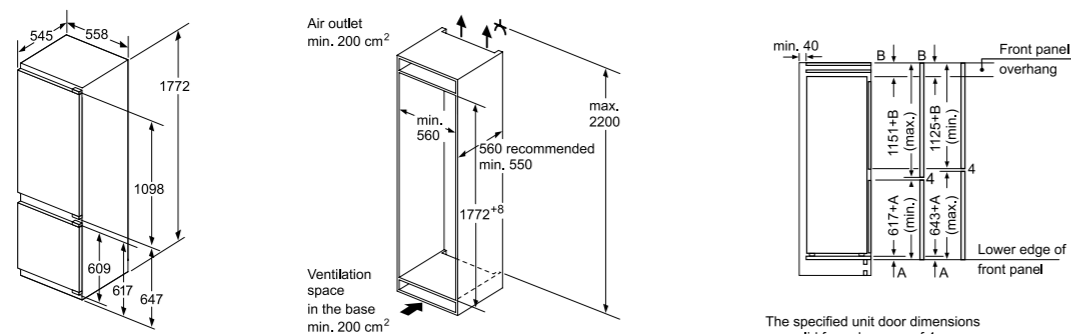

The specified unit door dimensions are valid for a door gap of 4 mm.

lowFrost bottom fridge freezers KI87VVE0G

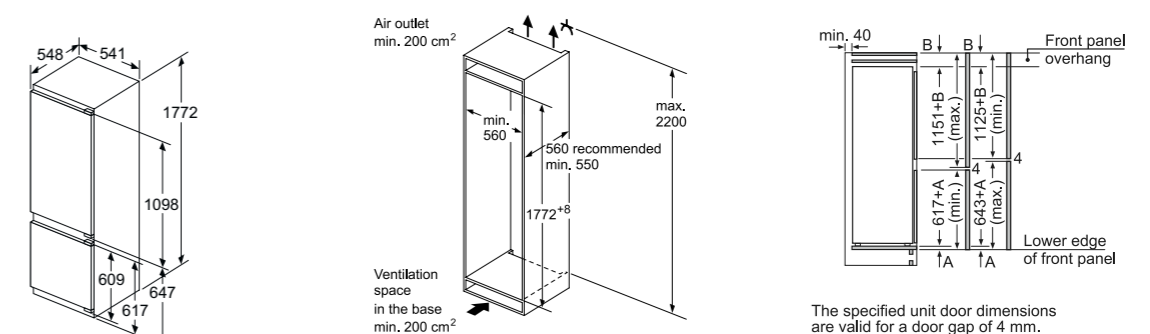

The specified unit door dimensions are valid for a door gap of 4 mm.

Cooling technical diagrams

lowFrost bottom fridge freezers KI87VSE0G and KI87VNSF0G

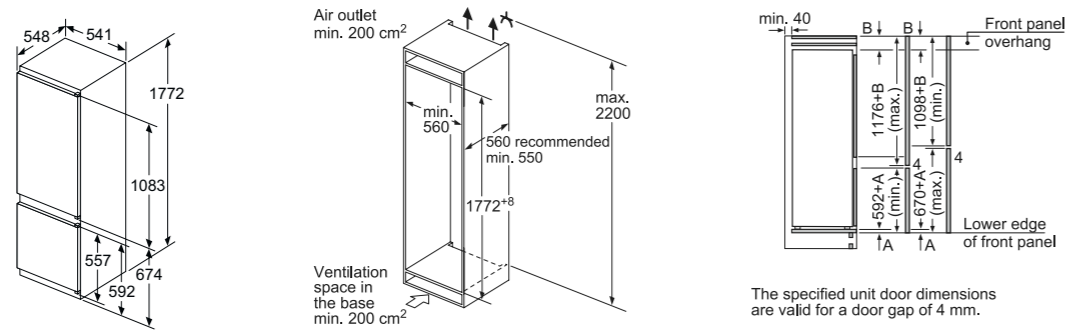

177cm freezers GI81NHCE0G and GI81NAEF0G

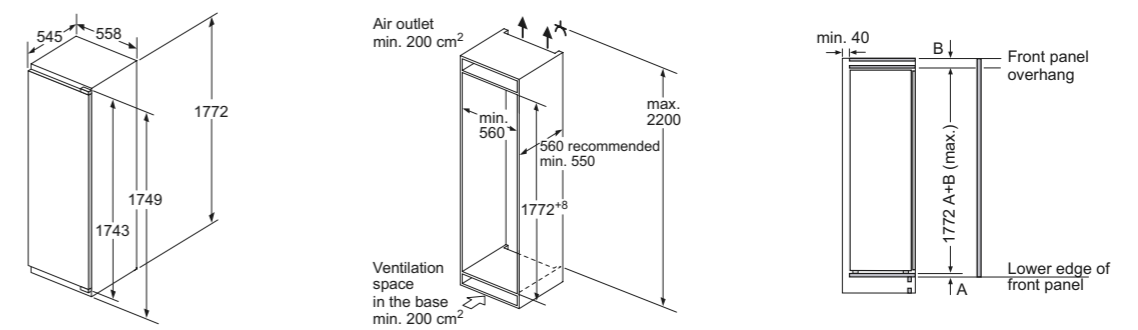

177cm fridges KI81RADE0G, KI81RAFE0G and KI82LAFFO

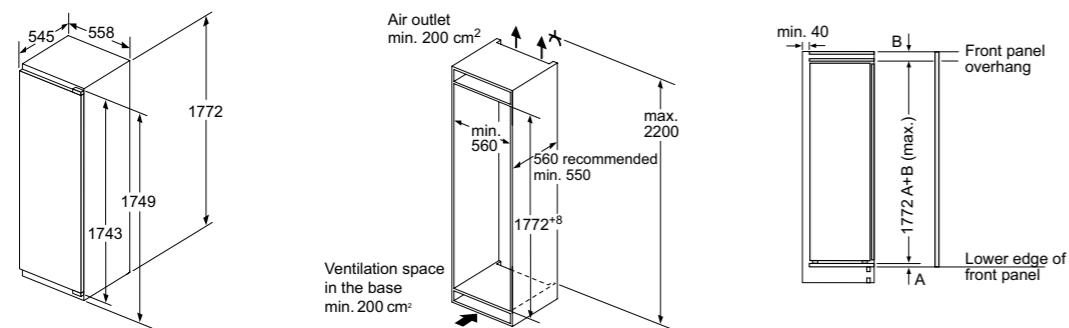

140cm fridge KI51RADFO

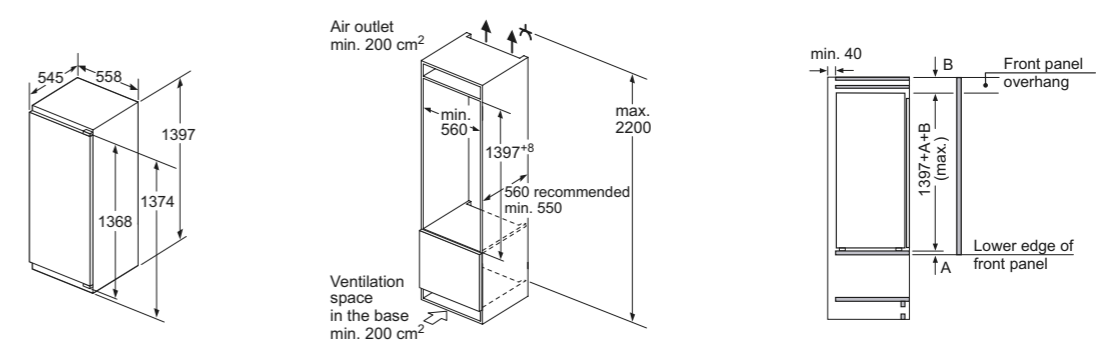

177cm fridges KI81RVSF0G

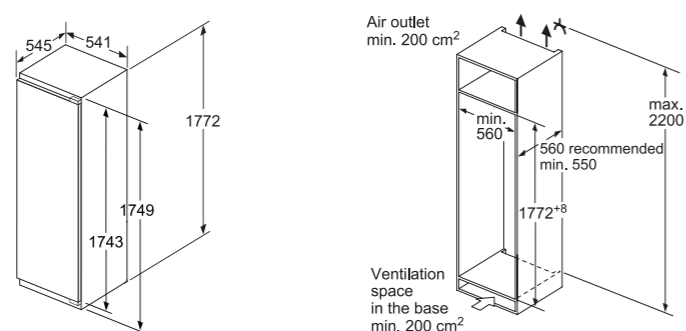

122cm fridge KI41RAFFO

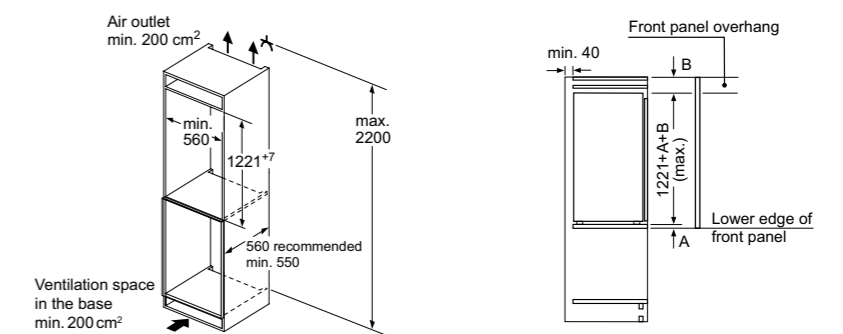

Cooling technical diagrams

87cm fridge and freezer KI21RAFF0 and GI21VAFE0

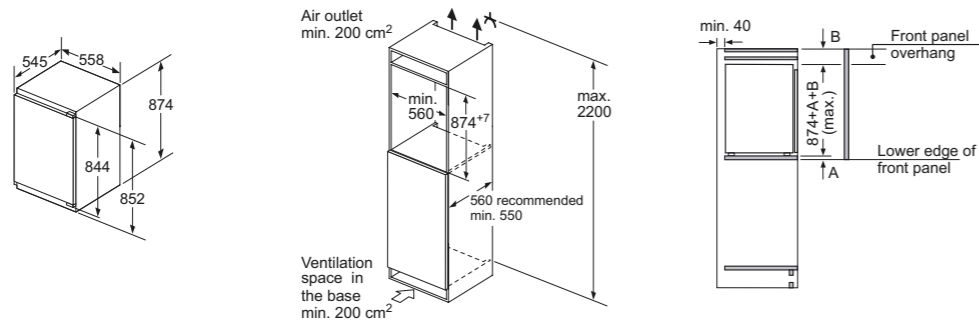

72cm freezer GI11VAFE0

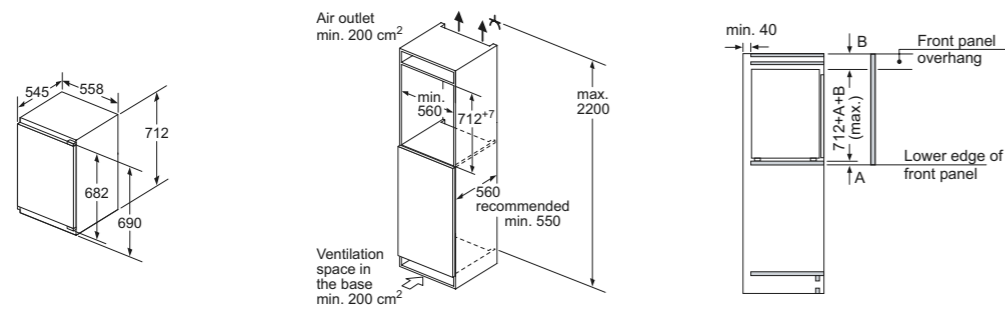

Dishwasher technical diagrams

Fully integrated dishwashers SN87YX03CE, SN85TX00CE AND SN85EX69CG

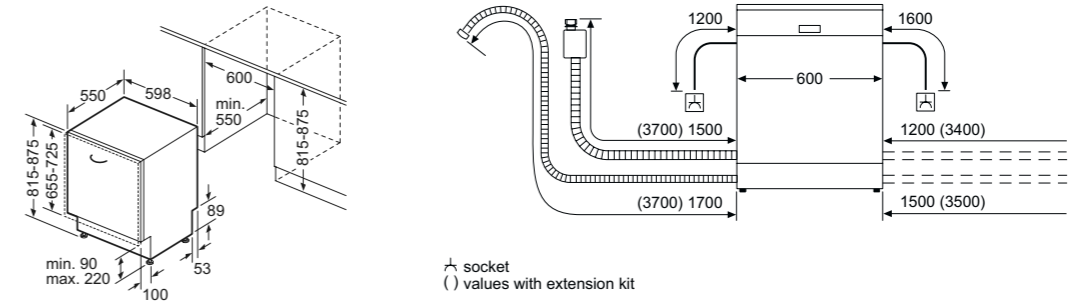

Fully integrated dishwasher SN95ZX61CG, SN93HX60CG and SN73HX42VG

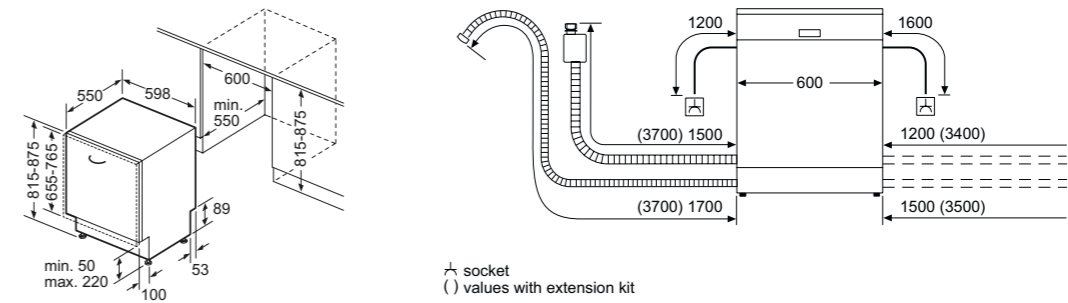

Fully integrated dishwasher SX93HX60CG

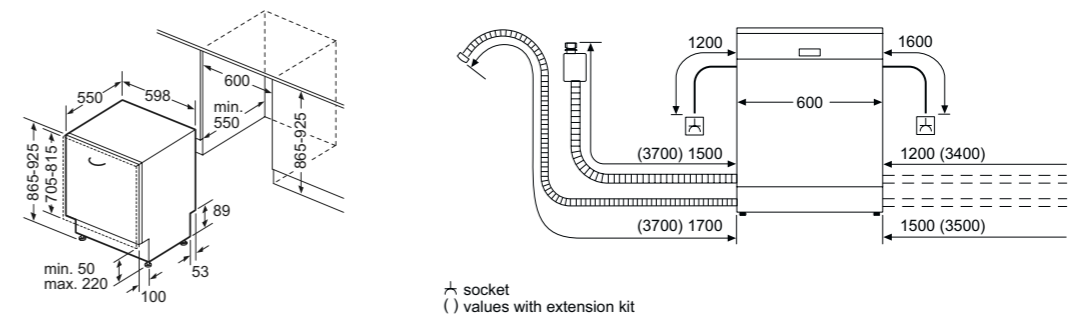

Dishwasher technical diagrams

45cm fully integrated dishwasher SR93EX20MG

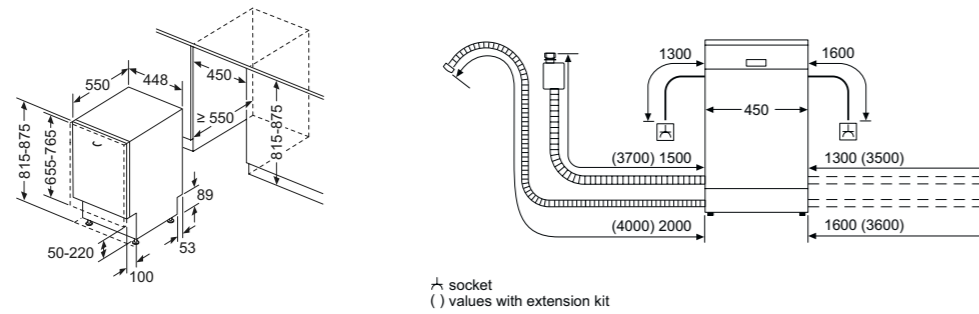

Dishwasher accessories

		SN87YX03CE	SN85TX00CE	SN95ZX61CG	SN85EX69CG	SX93HX60CG	SN93HX60CG	SN73HX42VG	SR93EX20MG
Aqua stop extension	SZ72010	■	■	■	■	■	■	■	■
Silver polishing cassette	SZ73001	■				■	■		
Decor strip - For 60cm Polinox base models, 81.5cm height	SZ73006							■	■
Decor strip - For 60cm and 45cm Stainless Steel base models, 81.5cm height	SZ73005	■	■	■	■		■		
Decor strip - For 60cm Stainless Steel base models, 86.5cm height	SZ73015					■			
Decor strip - For 60cm Stainless Steel base models installed off the ground, 81.5cm height	SZ73035	■	■	■	■		■		
Decor strip - For 60cm Stainless Steel base models installed off the ground, 86.5cm height	SZ73045					■			
Door attachment – brushed steel	SZ73056	■			■				
Drop hinge for tall cabinets	SZ73010	■	■		■				
Adjustable cutlery basket - 60cm dishwashers	SZ73100	■	■	■	■	■	■	■	
Adjustable cutlery basket - 45cm dishwashers	SZ73145								■
Wine glass holder accessory (Glass secure tray)	SZ73300	■	■	■	■	■	■	■	
Rack insert for stemware dishwasher	SZ73640	■		■	■	■	■	■	

Home Laundry technical diagrams

Integrated washing machines WI14W502GB, WI14W501GB, WI14W302GB and WI14W301GB

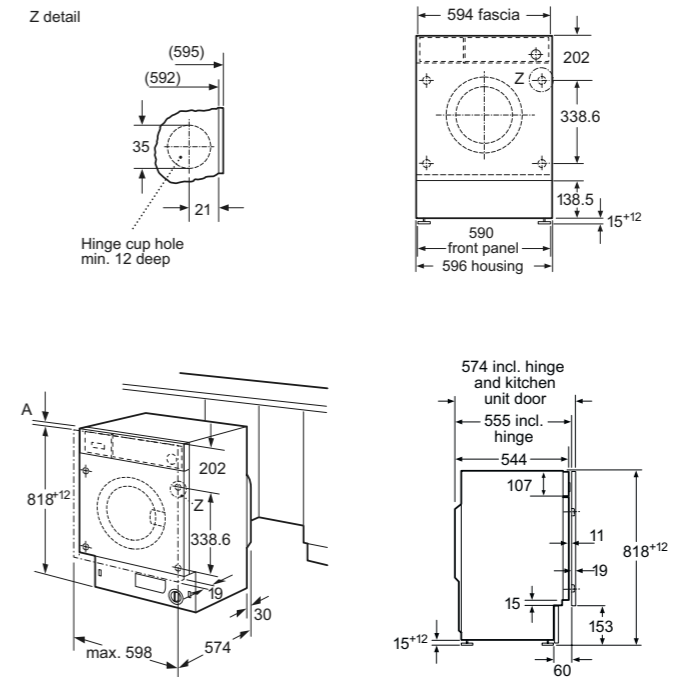

Integrated washer dryers WK14D542GB and WK14D322GB

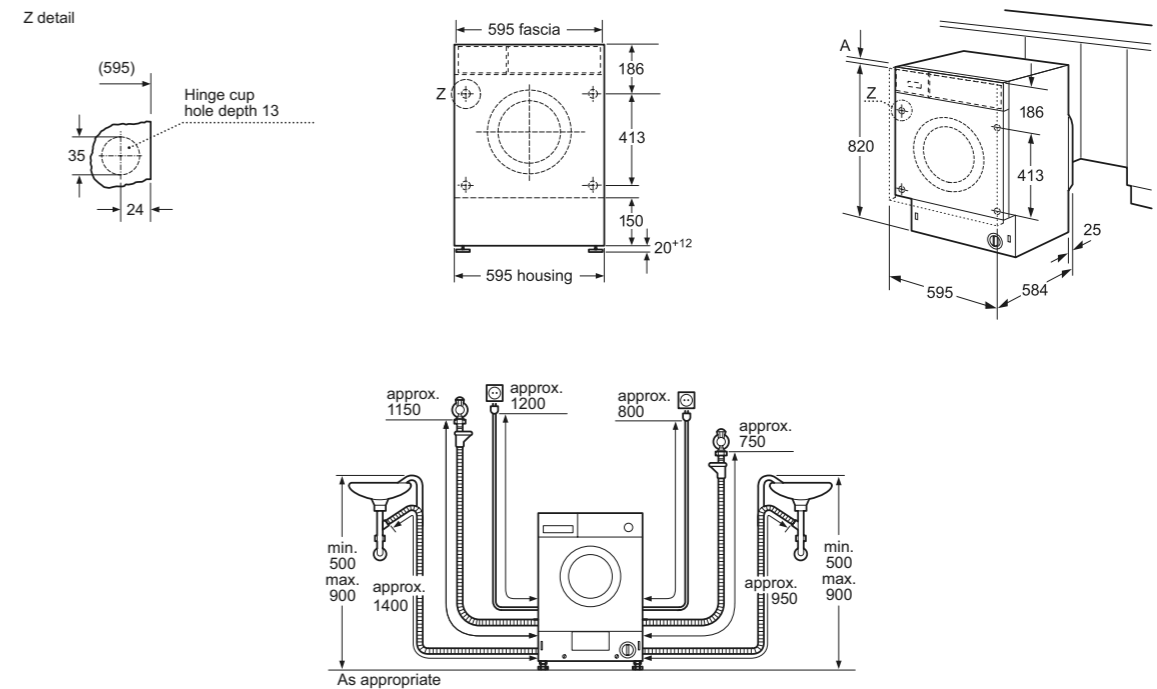

Notes

Models shown on front left to right:

CM678G4S6B compact oven, **BI630CNS1B** warming drawers, **CT636LES6** coffee machine, **KU21WAHG0G** wine cabinet and **ED711FQ15E** inductionAir Plus hob

Siemens, a division of BSH Home Appliances Ltd,
Grand Union House,
Old Wolverton Road, Wolverton,
Milton Keynes, MK12 5PT
Tel: 0344 892 9040

siemens-home.bsh-group.com/uk

Showroom
Siemens London,
Home of studioLine,
14 Wigmore Street,
London, W1U 2RE
Tel: 0330 134 3100
Email: SiemensLondon@Siemens-Home.BSH-Group.com

BSH Home Appliances Ltd,
M50 Business Park,
Ballymount,
Dublin 12
Tel: 1890 626041

siemens-home.bsh-group.com/ie

Disclaimer

This brochure is current as from the publication date and supersedes all previous brochures for these products. Whilst BSH Home Appliances Ltd believes that all information contained within this brochure is correct at the time of going to print, no representation or warranty, express or implied, is or will be made and no responsibility or liability is or will be accepted by BSH Home Appliances Ltd in relation to the accuracy or completeness of this information and any liability is expressly disclaimed. To the extent permitted by law, BSH Home Appliances Ltd expressly excludes: i) all conditions, warranties and other terms which might otherwise be implied by statute, common law or the law of equity and ii) any liability for any direct, indirect or consequential loss or damage (including, without limitation, damages for loss of business or loss of profits) arising in contract, tort or otherwise from the use of or reliance on any information contained within this brochure or from any action or decision taken as a result of such use or reliance. BSH Home Appliances Ltd reserves the right to modify technical data and all other information contained within this brochure without notice. All rights reserved.

No part of this publication may be reproduced in any form or without the prior written permission of BSH Home Appliances Ltd.

This brochure should not be regarded as an infallible guide nor as an offer of sale for a particular product.

Due to variables in the reproduction process, colours of actual products may vary slightly from those depicted. We recommend a visit to a Siemens dealer to confirm that specifications and colours are to your satisfaction.

Valid from June 2022
SIEMBI2022



SIEMENS

Siemens Home Appliances