

Hotpoint

Hotpoint

**BUILT-IN
KITCHEN STUDIO**

Hotpoint BUILT-IN KITCHEN STUDIO

Hotpoint



YOUR *trusted partner*, HELPING YOU CARE FOR YOUR HOME FOR OVER 100 YEARS

Our thoughtful home solutions have been relied on for generations to help protect you from mishaps. From cooking appliances that prevent pans boiling over, to washing machines that remove more than 100 stains at low, protective temperatures, you can count on us to be there for you when you need us.

Hotpoint



TABLE OF CONTENTS

COOKING	04
Ovens 04	
Microwave Ovens 12	
Induction Hobs & Ceramic Hobs 20	
Gas Hobs 28	
Hoods 36	
DISHWASHERS	50
REFRIGERATION	58
LAUNDRY	70
Washing Machines 72	
Washer Dryers 73	
SERVICE & CARE	76

HOTPOINT *ovens*

Count on Hotpoint's thoughtful home solutions to help you cook with confidence.

Hotpoint



Hotpoint

MULTIFLOW TECHNOLOGY



FOOD THAT'S COOKED *consistently* EVEN THROUGHOUT

Multiflow technology, available across Hotpoint's full range of electric ovens, distributes constant heat to every corner of the oven, controlling the temperature to within a precise 2 degrees. For consistently even cooking with no burnt edges or raw middles - whichever shelf you're using.



MEAT PROBE



COOK SUCCULENT JOINTS OF MEAT *without opening* THE OVEN DOOR

Monitor the internal temperature of your meat to easily know when it's reached the desired temperature.

ACTIVE STEAM



PREVENT FOOD FROM *overcooking* AND *drying out*

Cooking with steam delivers deliciously crisp results on the outside while keeping the centre soft and succulent. Choose from three levels of steam, dependent on what you're cooking.



TAKE THE *effort* OUT OF CLEANING THE OVEN



Our ovens offer a number of self-cleaning programmes and features, so you never have to spend hours cleaning the oven again.

PYROLYTIC CLEANING

A special cycle safely locks the oven door and heats up to 470°C to burn off any fat and grease without having to use detergents. Simply dust away any residue once the cycle is complete.

CATALYTIC LINERS

Catalytic liners are special panels that catch fat spits and grease, removing them naturally during the cooking process, so you can spend more time cooking and less time cleaning.

HYDRO CLEANING

A 35 minute self-cleaning steam programme loosens fat and food residue from the special coating on the sides of the oven, that can be simply wiped away after the cycle has ended.



Code 859990967680
EAN 5016108967683

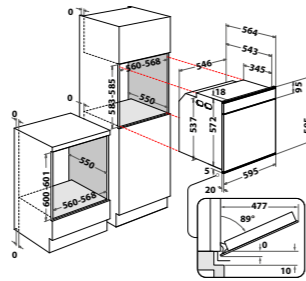

SI9 891 SP IX

- Class 9
- Energy Rating A+
- Multiflow Technology
- Pyrolytic Cleaning
- Meat Probe
- Multi-Recipes
- Telescopic Shelves



Code 859990967660
EAN 8007842967661

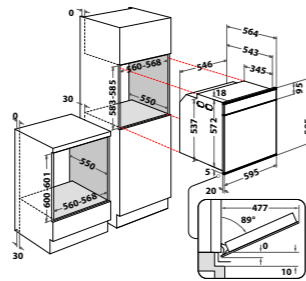

SI9 891 SC IX

- Class 9
- Energy Rating A+
- Multiflow Technology
- Catalytic Liners
- Meat Probe
- Multi-Recipes
- Telescopic Shelves



Code 859991575130
EAN 5054645575138

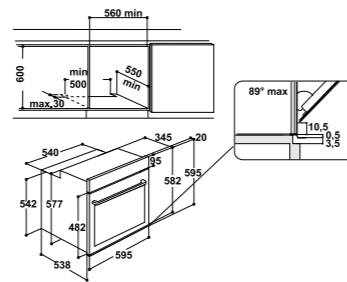

SI9 S8C1 SH IX H

- Class 9
- Energy Rating A+
- Active Steam
- Multiflow Technology
- Hydro Cleaning
- Telescopic Shelves
- Soft Close Door



Code 859990967690
EAN 5016108967690

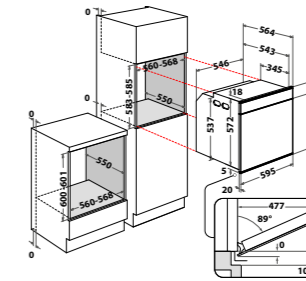

SI7 891 SP IX

- Class 7
- Energy Rating A+
- Multiflow Technology
- Pyrolytic Cleaning
- Meat Probe
- Multi-Recipes
- Telescopic Shelves



Code 859990967880
EAN 5016108967881

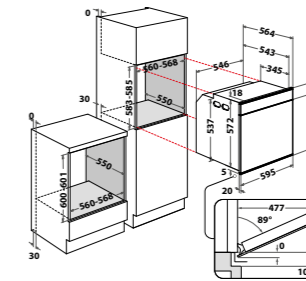

SI7 871 SC IX

- Class 7
- Energy Rating A+
- Multiflow Technology
- Electronic Temperature Control
- Catalytic Liners
- Touch Dials
- Telescopic Shelves



Code 859990967970
EAN 5016108967973

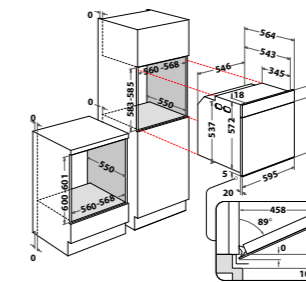

SI5 854 P IX

- Class 5
- Energy Rating A+
- Multiflow Technology
- Electronic Temperature Control
- Pyrolytic Cleaning
- Expert Recipes



Code 859990967960
EAN 5016108967966

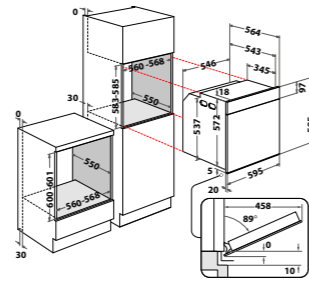

SI5 851 C IX

- Class 5
- Energy Rating A+
- Multiflow Technology
- Electronic Temperature Control
- Catalytic Liners
- Expert Recipes



Code 859991001440
EAN 5054645001446

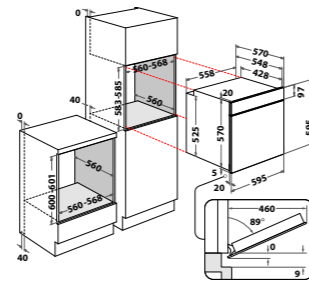

SA3 540 H IX

- Class 3
- Energy Rating A
- Multiflow Technology
- Electronic Temperature Control
- Hydro Cleaning
- Digital Display
- Removable Door



Code 859991001450
EAN 5054645001453

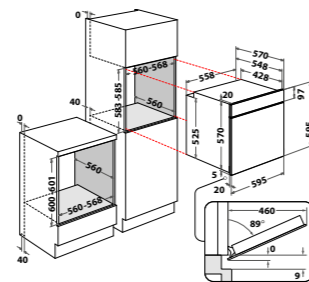

SA3 544 C IX

- Class 3
- Energy Rating A
- Multiflow Technology
- Electronic Temperature Control
- Catalytic Liners
- Digital Display
- Removable Door



Code 869991022840
EAN 5054645022847

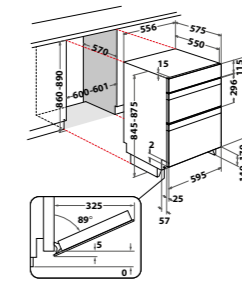

DKU5 541 J C IX

- Class 5
- Energy Rating A/A
- Fan
- Catalytic Liners
- Digital Display
- Pop-Out Controls
- Telescopic Shelves



Code 869991022850
EAN 5054645022854

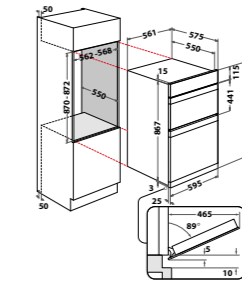

DKD5 841 J C IX

- Class 5
- Energy Rating A/A
- Multifunction
- Catalytic Liners
- Digital Display
- Pop-Out Controls
- Telescopic Shelves

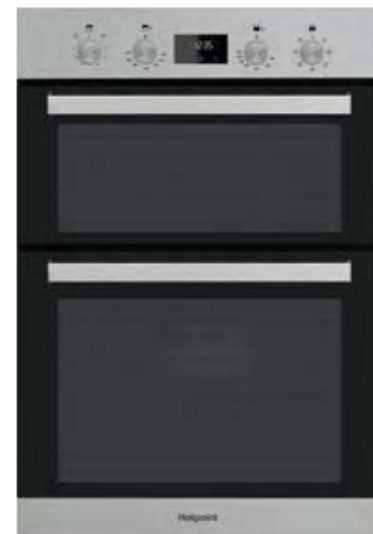

Code 869991022910
EAN 5054645022915

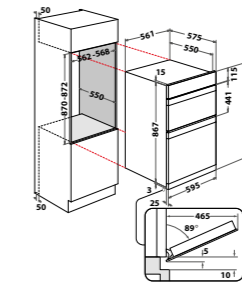

DKD3 841 IX

- Class 3
- Energy Rating A/A
- Multifunction
- Catalytic Liners
- Digital Display
- Twin Grill
- Telescopic Shelves

	SI9 891 SP IX	SI9 891 SC IX	SI9 S8C1 SH IX H	SI7 891 SP IX	SI7 871 SC IX
SPECIFICATION					
CAPACITY (L)	73	73	73	73	73
ENERGY RATING	A+	A+	A+	A+	A+
DIMENSIONS (H x D x W mm)	595 x 595 x 564	595 x 595 x 564	595 x 595 x 564	595 x 595 x 564	595 x 595 x 564
COLOUR	Inox	Inox	Inox	Inox	Inox
USER INTERFACE	Text Assisted Digital Display	Text Assisted Digital Display	Text Assisted Digital Display	Text Assisted Digital Display	Text Assisted Digital Display
CONTROL	Touch	Touch	Touch	Touch	Touch
CONNECTION	UK Plug	UK Plug	UK Plug	UK Plug	UK Plug
ACCESSORIES	1 shelf 1 deep tray 1 baking tray 1 grid grill pan set	1 shelf 1 deep tray 1 baking tray 1 grid grill pan set	1 shelf 1 deep tray 1 baking tray 1 grid grill pan set	1 shelf 1 deep tray 1 baking tray 1 grid grill pan set	1 shelf 1 deep tray 1 baking tray 1 grid grill pan set

	SI9 891 SP IX	SI9 891 SC IX	SI9 S8C1 SH IX H	SI7 891 SP IX	SI7 871 SC IX	SI5 854 P IX	SI5 851 C IX	SA3 540 H IX	SA3 544 C IX	DKU5 541 J C IX	DKD5 841 J C IX	DKD3 841 IX
TECHNOLOGY												
MULTIFLOW TECHNOLOGY	●	●	●	●	●	●	●	●	●			
ELECTRONIC TEMPERATURE CONTROL	●	●	●	●	●	●	●	●	●			
ACTIVE STEAM			●									
MEAT PROBE	●	●										
ROTISSERIE	●			●		●		●				
TELESCOPIC SHELVES	●	●	●	●	●		●			●	●	●
SOFT CLOSE DOOR	●	●	●	●	●							
NUMBER OF MULTI-RECIPES	36	36	33	28								
NUMBER OF EXPERT-RECIPES					9	6	6	2	2			
CLEANING METHOD	Pyrolytic Cleaning	Catalytic Liners	Hydro Cleaning	Pyrolytic Cleaning	Catalytic Liners	Pyrolytic Cleaning	Catalytic Liners	Hydro Cleaning	Catalytic Liners	Catalytic Liners	Catalytic Liners	Catalytic Liners
TILTING GRILL		●	●		●		●	●	●			
TWIN GRILL										●	●	●

HOTPOINT *microwaves*

So much more than just reheating and defrosting.

Hotpoint



DYNAMIC CRISP



FOR MEALS THAT
ARE *crisp* AND FULL
OF *flavour*

Dynamic Crisp enables you to cook foods such as pizza, halloumi & even a full English breakfast by quickly reaching the ideal temperature for browning and crisping.



MICROWAVES
& COMPACTS

DYNAMIC DEFROST



Quickly AND *safely*
DEFROST MEAT, POULTRY,
FISH, VEGETABLES OR BREAD

The ideal programme for defrosting food quickly and safely, preserving all the nutrients. Simply select the type of food and its weight: the microwave will automatically calculate the time required for even defrosting.



AUTOCLEAN



TAKE THE *effort*
OUT OF CLEANING

Never worry about cleaning with our AutoClean function. Simply select the programme, and let the microwave do the rest. The special interior coating makes wiping away any residue quick and easy.

QUARTZ GRILL



HEAT IN *seconds*

The powerful Quartz Grill instantly pre-heats, helping to create deliciously golden pizzas, gratins and lasagnes.



MULTIWAVE TECHNOLOGY



EVEN COOKING,
HEATING AND
DEFROSTING *in*
a hurry

Consistent and even cooking throughout your dish without the need to stir. This innovative technology perfects the microwave distribution which ensures they reach every part of the dish.

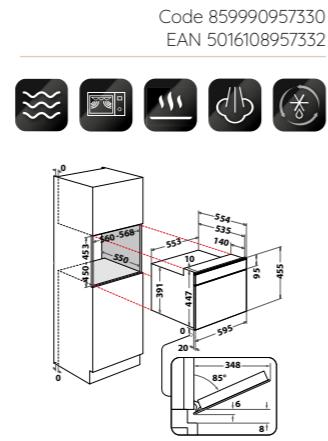

MP 996 IX H

- Class 9
- Multiwave Technology
- Microwave Combi
- Dynamic Crisp
- Steamer
- Dynamic Defrost

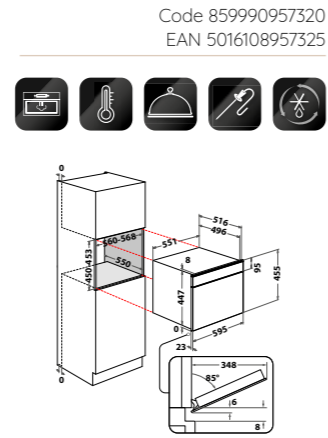

MS 998 IX H

- Class 9
- Compact Steam Oven
- Electronic Temperature Control
- Multi-Recipes
- Meat Probe
- Dynamic Defrost

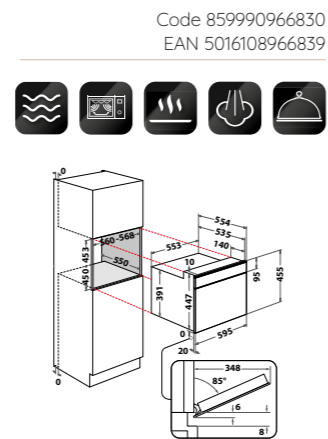

MP 776 IX H

- Class 7
- Multiwave Technology
- Microwave Combi
- Dynamic Crisp
- Steamer
- Multi-Recipes

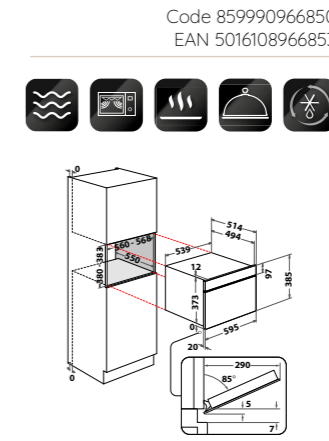

MD 554 IX H

- Class 5
- Multiwave Technology
- Microwave and Grill
- Dynamic Crisp
- Multi-Recipes
- Dynamic Defrost

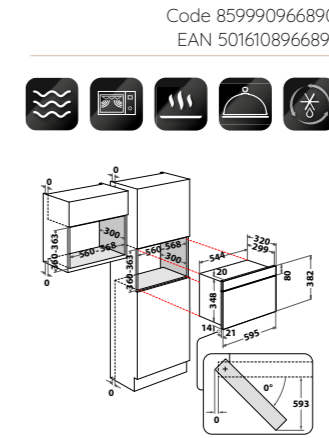

MN 314 IX H

- Class 3
- Multiwave Technology
- Microwave and Grill
- Dynamic Crisp
- Multi-Recipes
- Dynamic Defrost

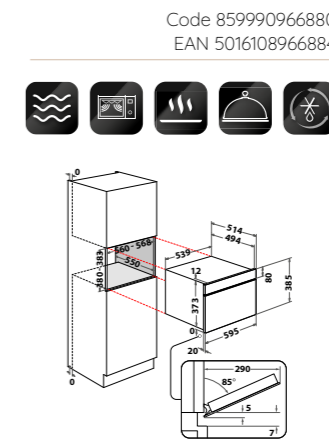

MD 344 IX H

- Class 3
- Multiwave Technology
- Microwave and Grill
- Dynamic Crisp
- Multi-Recipes
- Dynamic Defrost



Code 869991591620
EAN 5054645591626

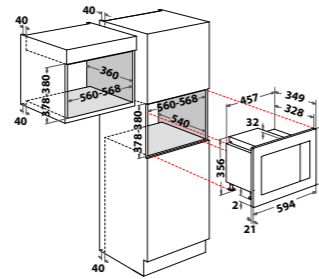

MF20G IX H

- Class 3
- Microwave and Grill
- Auto Clean
- Quartz Grill
- Multi-Recipes
- Dynamic Defrost



Code 869991591550
EAN 5054645591558

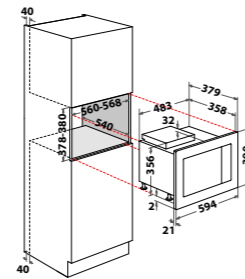

MF25G IX H

- Class 3
- Microwave and Grill
- Auto Clean
- Quartz Grill
- Multi-Recipes
- Dynamic Defrost



Code 869990957350
EAN 5016108957356

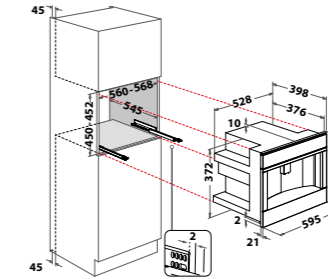

CM 9945 H

- Class 9
- Coffee Machine
- Fully Automatic
- Adjustable Grinding Level
- 5 Coffee Options
- Cappuccino
- Touch Control



Code 869990957370
EAN 8007842957372

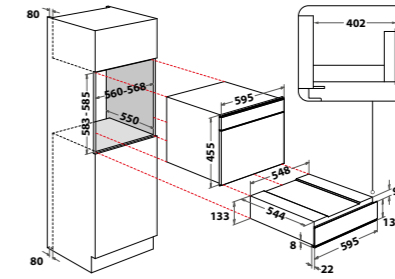

WD 914 NB

- Class 9
- Warming Drawer
- Pre-heat Plates
- 20 L
- Temperature Control



Code 869990966910
EAN 8007842966916

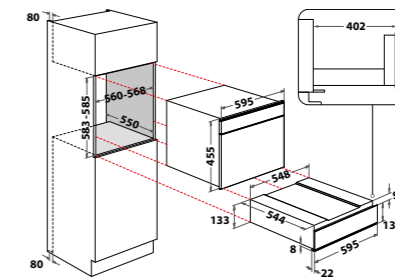

WD 714 IX

- Class 7
- Warming Drawer
- Pre-heat Plates
- 20 L
- Temperature Control

	MP996 IXH	MP776 IXH	MD554 IXH	MD344 IXH	MN 314 IX	MF25G	MF20G	MS 998 XH	CM9945	WD 914 NB	WD 714 IX
SPECIFICATION											
CAPACITY (L)	40	40	31	31	22	25	20	29	-	20	20
DIMENSIONS (H x D x W mm)	455 x 595 x 560	455 x 595 x 560	385 x 595 x 468	385 x 595 x 468	382 x 595 x 320	390 x 594 x 379	390 x 594 x 349	455 x 595 x 537	455 x 595 x 398	595 x 550 x 116	595 x 550 x 116
COLOUR	Inox	Inox	Inox	Inox	Inox	Inox	Inox	Inox	Inox	Black	Inox
USER INTERFACE	Text Assisted Digital Display	Graphic Assisted Digital Display	Graphic Display	Digital Display	Digital Display	Digital Display	Digital Display	Text Assisted Digital Display	Text Assisted Digital Display	-	-
CONTROL	Touch	Touch	Monodial	Knobs	Buttons	Touch + Knob	Touch + Knob	Touch	Touch	Button	Button
DOOR OPENING	Drop down	Drop down	Drop down	Drop down	Push Button Door (Side Swing)	Push Button Door (Side Swing)	Push Button Door (Side Swing)	Drop down	-	Push Pull Mechanism	Push Pull Mechanism
CONNECTION	UK Plug	UK Plug	UK Plug	UK Plug	UK Plug	UK Plug	UK Plug	UK Plug	UK Plug	Cable	Cable
ACCESSORIES	1 Grill Grid 1 Baking Tray 1 Crisp Plate 1 Crisp Handle 1 Steamer 1 Cover Plate	1 Grill Grid 1 Baking Tray 1 Crisp Plate 1 Crisp Handle 1 Steamer 1 Cover Plate	1 grill Grid 1 Crisp Plate 1 Crisp Handle 1 Cover Plate	1 Grill Grid 1 Crisp Plate 1 Crisp Handle 1 Cover Plate	1 Grill Grid 1 Crisp Plate 1 Crisp Handle 1 Cover Plate	1 Grill Grid	1 Grill Grid	Combi Steam Set	-	-	-
TYPE OF COMPACT APPLIANCE	Microwave Combi	Microwave Combi	Microwave and Grill	Microwave and Grill	Microwave and Grill	Microwave and Grill	Microwave and Grill	Compact Steam Oven	Automatic Coffee Machine	Warming Drawer	Warming Drawer
MICROWAVE POWER	900W	900W	1000W	1000W	750W	900W	800W	-	-	-	-
NUMBER OF MICROWAVE POWER LEVELS	7	7	7	7	4	7	6	-	-	-	-
GRILL TYPE	Standard Grill	Standard Grill	Quartz	Quartz	Quartz	Quartz	Quartz	-	-	-	-
GRILL POWER	1600W	1600W	800W	800W	700W	1000W	1000W	-	-	-	-
TECHNOLOGY											
MULTIWAVE TECHNOLOGY	●	●	●	●	●						
DYNAMIC CRISP	●	●	●	●	●						
DYNAMIC DEFROST	●	●	●	●	●	●	●	●			
MULTI-RECIPES	●	●	●	●	●	●	●	●			
AUTOCLEAN						●	●				
MEAT PROBE								●			
ADJUSTABLE GRINDING LEVEL									●		
5 COFFEE OPTIONS									●		
CAPPUCCINO									●		
PRE-HEAT PLATES										●	●



INDUCTION hobs

Your trusted partner
in the kitchen

Hotpoint

MY MENU



YOUR *perfect* KITCHEN ASSISTANT

Prevent cooking mishaps with My Menu. Simply select one of the automatic functions, **melting**, **boiling**, **keep warm**, and **slow cooking**, to cater for all your cooking needs. Use melting to slowly melt chocolate or butter without risk of burning, slow cooking for low and slow cooked stews, soups and joints of meat, keep warm for maintaining serving temperature, great for breakfast or busy family mealtimes, boiling to rapidly reach boiling point, without food sticking or the pan over boiling.



ACTIVE HEAT



CHANGE THE *temperature* OF YOUR HOB BY SIMPLY MOVING THE PAN

With Active Heat, the whole cooking surface is divided into independent zones with different temperature levels (low, medium, and high). So you can alter the temperature of your cooking by simply moving the pan.

SLIDER CONTROL



Superior HEAT CONTROL

Directly control the power of each cooking zone using the responsive slider. Hotpoint inductions hobs offer between 9-18 power levels, allowing you superior heat control.

BOOST POWER



EXTRA *power* AND *control* FOR WHEN AN INJECTION OF HEAT IS NEEDED

Perfect when boiling water or searing meat. When this function is activated, within seconds the heat reaches its maximum level for 4 minutes: boosting cooking speed, whilst retaining full control.



TOTAL FLEXI



THE *flexibility* TO COOK THE WAY YOU WANT

Total Flexi features 8 independantly controlled coils, giving you maximum freedom to customise your cooking zones to suit your needs. This unique surface evenly distributes temperature for large pans or multiple smaller pots.

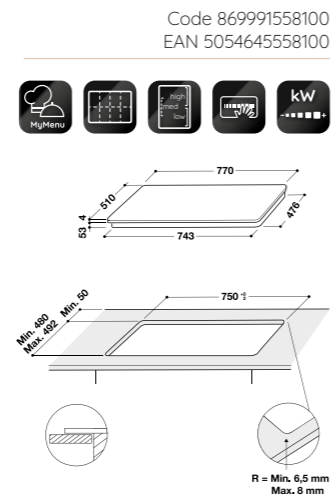

ACP 778 C/BA

- * My Menu (86 functions)
- * Total Flexi
- * Active Heat
- * Assisted Display with Slider Control
- * Boost Power

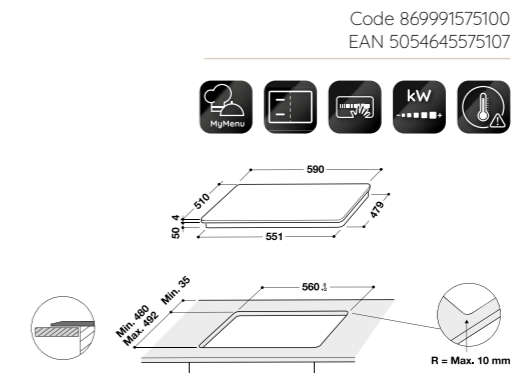
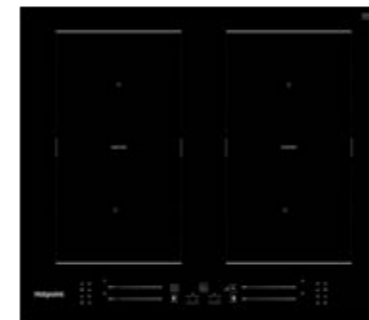

TS 9960C BF

- * My Menu (4 Functions)
- * Flexi Duo
- * Slider Control
- * Boost Power
- * Residual Heat Indicator

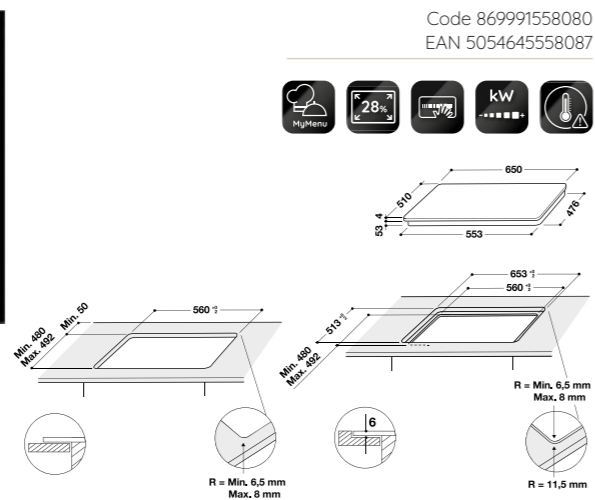
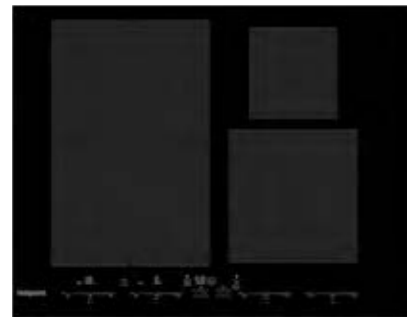

ACO 654 NE

- * My Menu (6 functions)
- * Flexi Pro
- * Slider Control
- * Boost Power
- * Residual Heat Indicator

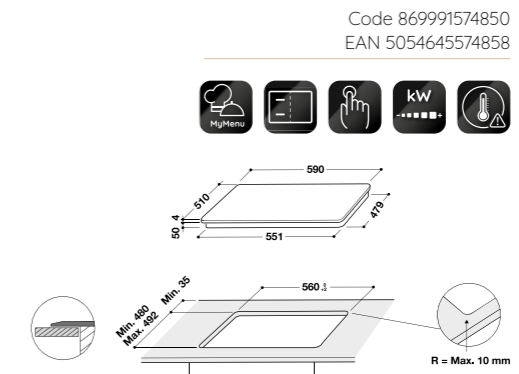
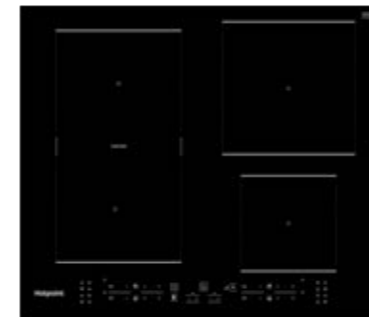

TB 7960C BF

- * My Menu (4 Functions)
- * Flexi Duo
- * Touch Buttons Control
- * Boost Power
- * Residual Heat Indicator

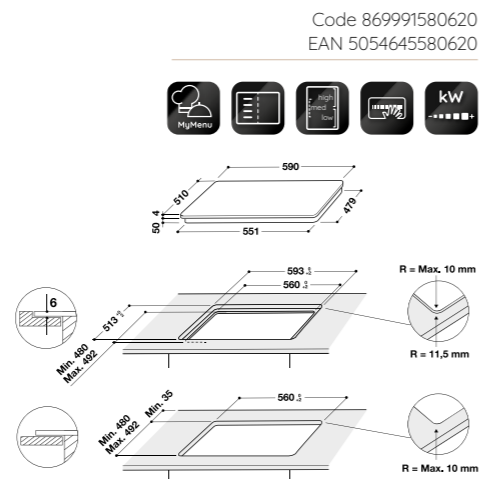
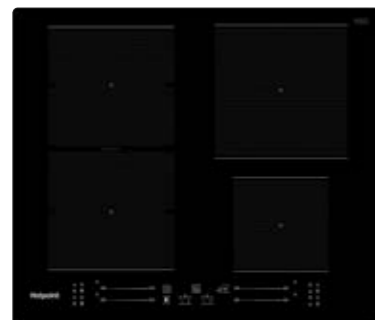

TS 5760F NE

- * My Menu (4 Functions)
- * Flexi Space
- * Active Heat
- * Slider Control
- * Boost Power

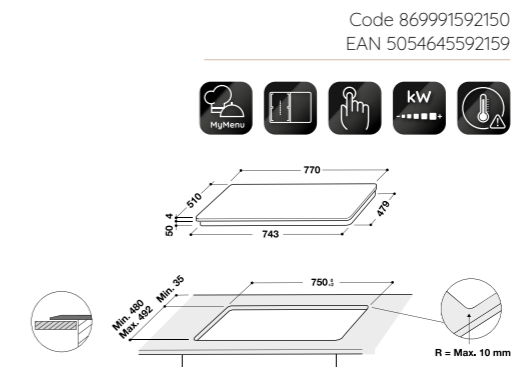
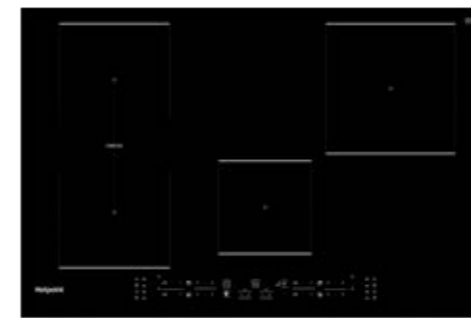

TB 3977B BF

- * My Menu (4 Functions)
- * Combi Duo
- * Touch Buttons Control
- * Boost Power
- * Residual Heat Indicator

INDUCTION HOBS

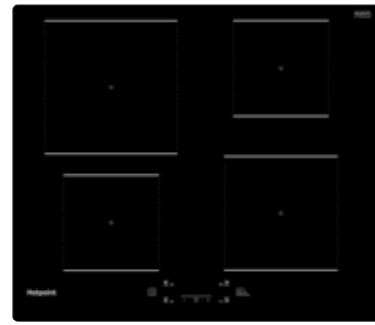

Code 869991589530
EAN 5054645589531

TQ 1460S NE



- * My Menu (4 Functions)
- * 4 Independent Zones
- * Touch Buttons Control
- * Boost Power
- * Residual Heat Indicator

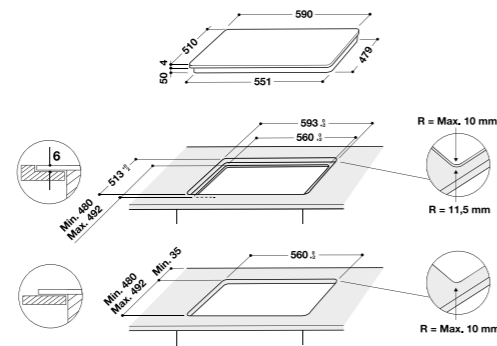

CERAMIC HOBS

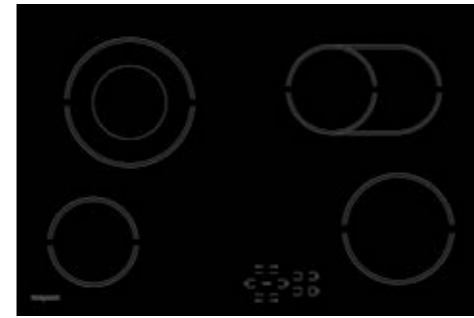

Code 869991043210
EAN 5054645043217

HR 724 B H



- * Touch Control
- * Oval Zone
- * Double Ring Zone
- * Residual Heat Indicator
- * Timer

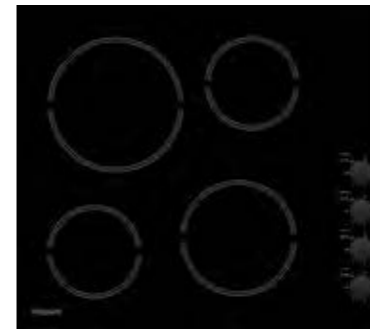
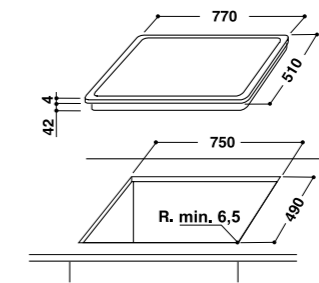

Code 869991043300
EAN 5054645043309

HR 619 C H



- * Knobs Control
- * Standard 4 Zones
- * 3 Different Sized Zones
- * Easy Cleaning

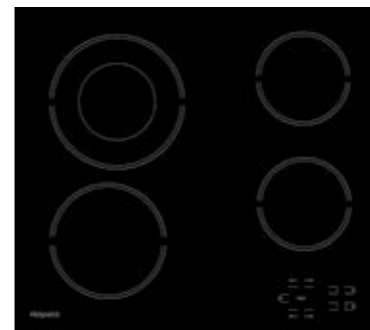
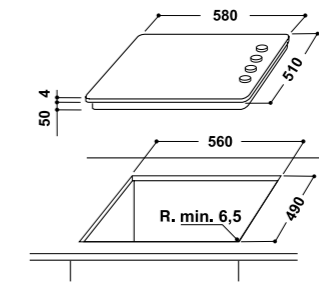

Code 869991043020
EAN 5054645043026

HR 612 C H



- * Touch Control
- * Residual Heat Indicator
- * Timer
- * Childlock
- * Easy Cleaning

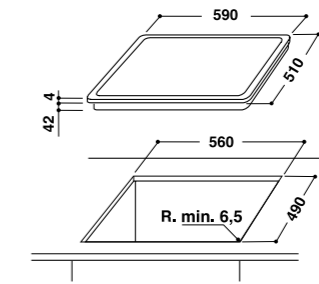

INDUCTION HOBS

INDUCTION & CERAMIC HOBS

	ACP 778 C/BA	ACO 654 NE	TS 5760F NE	TS 9960C BF	TB 7960C BF	TB 3977B BF	TQ 1460S NE	HR 724 B H	HR 612 C H	HR 619 C H
SPECIFICATION										
DIMENSIONS (W x D mm)	770 x 510	650 x 510	590 x 510	590 x 510	590 x 510	770 x 510	590 x 510	770 x 510	580 x 510	580 x 510
COLOUR	Black	Black	Black	Black	Black	Black	Black	Black	Black	Black
CONTROL	-	-	-	-	-	-	-	Touch Control	Touch Control	Knobs Control
NUMBER OF POWER LEVELS	18	18	18	18	9	9	9	-	-	-
POWER MANAGMENT	●	●	●	●	●	●	●			
TECHNOLOGY										
NUMBER OF MY MENU FUNCTIONS	18	6	4	4	4	4	4	-	-	-
TOTAL FLEXI	●									
FLEXI PRO		●						●		
FLEXI SPACE			●					●		
FLEXI DUO				●	●					
COMBI DUO						●		●		
BOOSTER	●	●	●	●	●	●	●			
ACTIVE HEAT	●		●							
ASSISTED DISPLAY WITH SLIDER CONTROL	●									
SLIDER CONTROL		●	●	●						
TOUCH BUTTON CONTROL					●	●	●			
TIMER	●	●	●	●	●	●	●	●		
RESIDUAL HEAT INDICATOR	●	●	●	●	●	●	●	●	●	
EASY INSTALLATION	●	●	●	●	●	●	●			
CHILD LOCK	●	●	●	●	●	●	●	●	●	
OVAL ZONE								●		
DOUBLE RING ZONE								●		
EASY CLEANING								●	●	●

GAS hobs

Freedom and precision
in the kitchen

Hotpoint

DIRECT FLAME TECHNOLOGY

NO MORE HOT AND COLD SPOTS, JUST *even heat* ACROSS THE ENTIRE SURFACE OF THE PAN

The powerful blue flame is delivered vertically via 420 tiny holes, so no heat is wasted around the sides of the pan, saving up to 20% in time and energy*. Preventing any hot or cold spots, for delicious results every time.

*Compared to a standard gas hob



FLAME CONTROL

SET THE *ideal flame level* FOR YOUR DISH

Ultimate control over your flame. Use the 9-level Flame Control to precisely set the right temperature for any dish or food type.



WOK BURNER

HEALTHY STIR FRY *in minutes*

The wok burner optimises the power of gas and allows quick and uniform cooking, delivering even heat around the pan, and is 15% faster than standard burners.



GAS ON GLASS

ACHIEVE A *long-lasting shine*

The Hotpoint gas hob has an elegant glass surface, which offers a fresh touch to your kitchen style and makes cleaning a breeze.



CAST IRON PAN SUPPORTS

CAST IRON PAN SUPPORTS YOU CAN *rely on*

Hard wearing and durable, keeping your kitchen looking great. Durable and sturdy for a professional finish. Cast iron's tolerance to prolonged contact with heat and ability to stand years of heavy-duty use makes it durable whilst retaining a professional look.





Code 869991004990
EAN 5054645004997

FTGHG 751 D/H(BK)



- Direct Flame Technology
- Cast Iron Pan Support
- Easy Cleaning
- 5 Burners

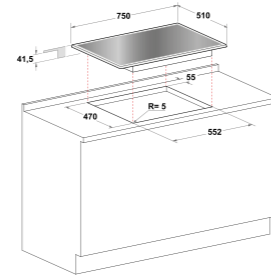

Code 869991002590
EAN 5054645002597

FTGHG 641 D/H(BK)



- Direct Flame Technology
- Cast Iron Pan Support
- Easy Cleaning
- 4 Burners

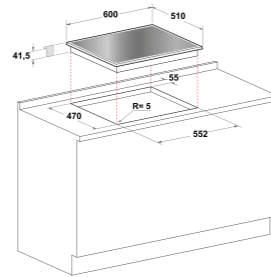

Code 869991634350
EAN 5054645634354

HGS 72S BK



- Flame Control
- Cast Iron Pan Support
- Wok Burner
- Easy Cleaning
- 5 Burners

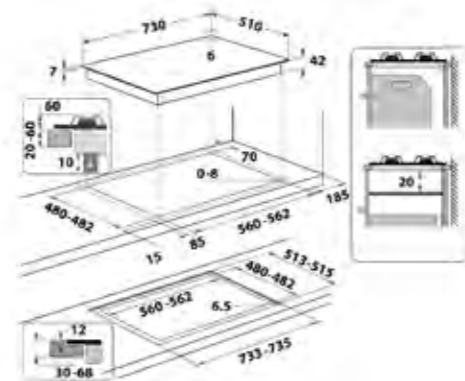

Code 869991634340
EAN 5054645634347

HGS 61S BK



- Flame Control
- Cast Iron Pan Support
- Easy Cleaning
- 4 Burners

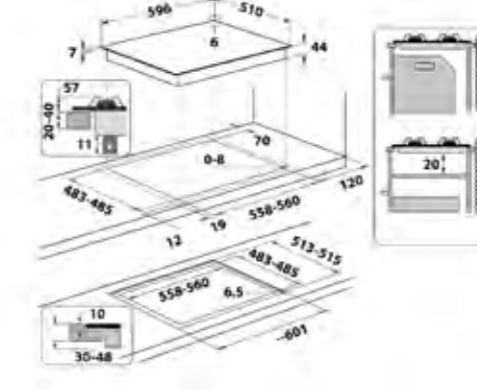

Code 869991011900
EAN 5054645011902

PHC 961 TS/IX/H



- 6 Burners
- Cast Iron Pan Support
- Wok Burner

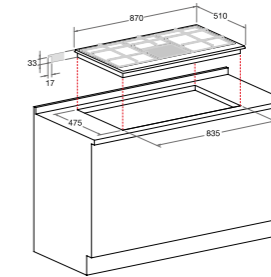

Code 869991635480
EAN 5054645635481

PPH 75G DF IX UK



- Flame Control
- Cast Iron Pan Support
- Wok Burner
- Easy Cleaning
- 5 Burners

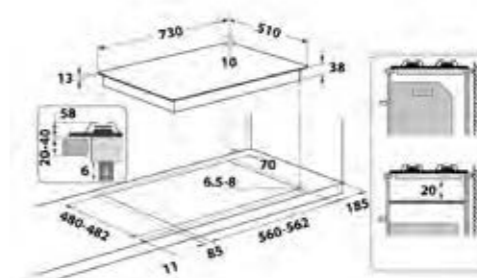

GAS HOBS



Code 869991635470
EAN 5054645635474

PPH 75P DF IX UK



- * Flame Control
- * Enamel Pan Support
- * Wok Burner
- * 5 Burners

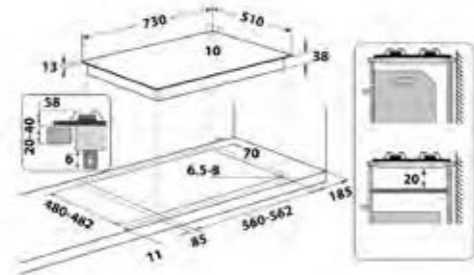

GAS HOBS



Code 869991635450
EAN 5054645635450

PPH 60P F IX UK



- * Flame Control
- * Enamel Pan Support
- * 4 Burners

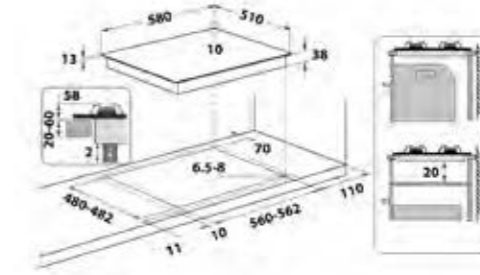

Code 869991635460
EAN 5054645635467

PPH 60G DF IX UK



- * Flame Control
- * Cast Iron Pan Support
- * Wok Burner
- * 4 Burners

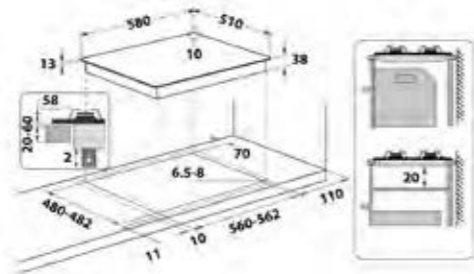

Code 859991636390
EAN 5054645636396

PPH 60P F NB



- * Flame Control
- * Enamel Pan Support
- * 4 Burners

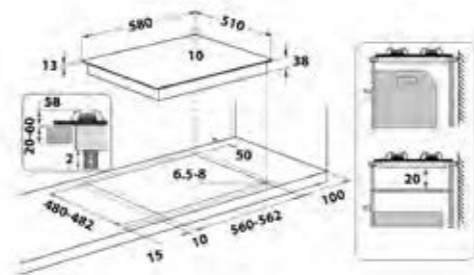

GAS HOBS

	FTGHG 751 D/H(BK)	FTGHG 641 D/H(BK)	PHC 961 TS/IX/H	HGS 72S BK
SPECIFICATION				
DIMENSIONS (W x D mm)	750 x 510	600 x 510	870 x 510	730 x 510
COLOUR	Black	Black	Inox	Black
NUMBER OF BURNERS	5	4	6	5
SURFACE	Gas on Glass	Gas on Glass	Gas on Metal	Gas on Glass

TECHNOLOGY

DIRECT FLAME TECHNOLOGY	●	●								
CAST IRON PAN SUPPORT	●	●	●	●	●	●	●			
WOK BURNER			●	●		●	●	●		
FLAME CONTROL (POWER LEVEL INDICATORS)				●	●	●	●	●	●	●

GAS HOBS

	HGS 61S BK	PPH 75G DF IX UK	PPH 60G DF IX UK	PPH 75P DF IX UK	PPH 60P F NB	PPH 60P F IX UK
SPECIFICATION						
DIMENSIONS (W x D mm)	596 x 510	730 x 510	580 x 510	730 x 510	580 x 510	580 x 510
COLOUR	Black	Inox	Inox	Inox	Black	Inox
NUMBER OF BURNERS	4	5	4	5	4	4
SURFACE	Gas on Glass	Gas on Metal	Gas on Metal	Gas on Metal	Gas on Metal	Gas on Metal



HOTPOINT *hoods*

A breath of fresh air
in the kitchen.

Hotpoint

BOOSTER

FOR *maximum* EXTRACTION POWER

For maximum extraction power use the booster option for the those stubborn, lingering odours. The timed booster switches off automatically after 5 minutes.



TOUCH CONTROL

CONTROL YOUR COOKING FROM THE TOUCH OF YOUR *fingertips*

The intuitive easy-to-use Touch Control interface provides simple and immediate access to all of your hood's settings and functions from the touch of a finger.



SILENCE CONTROL

A SINGLE TOUCH FOR *silence*

Without having to stop the hood, the Silence Control button allows direct access to the lowest noise level (up to 35dBA) with just a single touch. This feature allows you to choose amongst 4 levels, so you can select a sound level that is best suited to you and your kitchen



LED LIGHTING

Light up THE ENTIRE SURFACE OF YOUR HOB

Light up the entire surface of your hob without shadows with LED lighting, which also offers 90% energy savings, last 10 times longer, and emits less heat than conventional lamps.



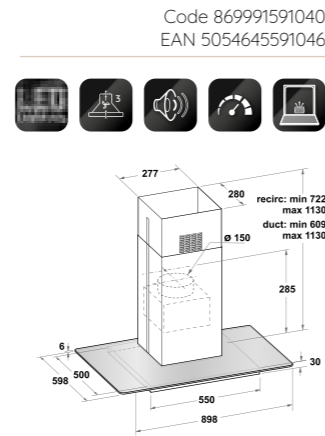

UIF 9.3F LB X

- Energy Rating B
- LED lighting
- 3 Extraction Speeds
- Silence Control
- Booster
- Dishwasher-safe Grease Filters

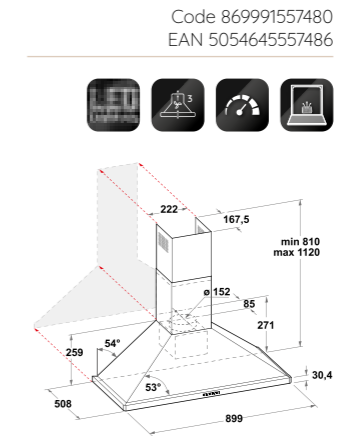

PHPN9.5FLMX/1

- Energy Rating D
- LED lighting
- 3 Extraction Speeds
- Booster
- Dishwasher-safe Grease Filters

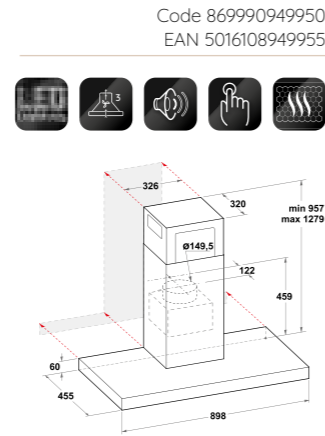

PHBS9.8CLTDK

- Energy Rating A
- LED lighting
- 3 Extraction Speeds
- Silence Control
- Touch Control
- Dual Filter

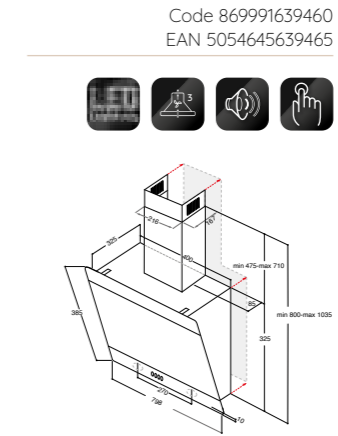

PHVP 82F LT K

- Energy Rating A
- LED lighting
- 3 Extraction Speeds
- Silence Control
- Touch Control

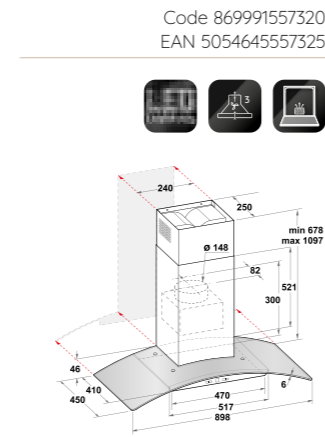

PHGC9.4FLMX

- Energy Rating D
- LED lighting
- 3 Extraction Speeds
- Dishwasher-safe Grease Filters



PHGC7.4FLMX

- Energy Rating D
- LED lighting
- 3 Extraction Speeds
- Booster
- Dishwasher-safe Grease Filters



Code 869990949820
EAN 5016108949825

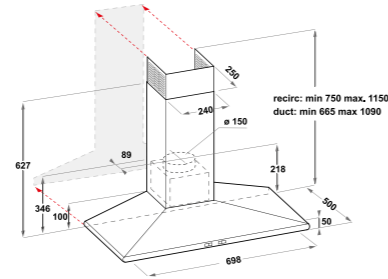

PHC7.7FLBIX

- Energy Rating B
- LED lighting
- 3 Extraction Speeds
- Silence Control
- Dishwasher-safe Grease Filters



Code 869990949780
EAN 5016108949788

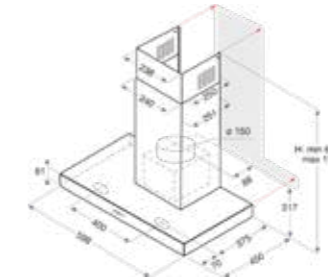

PHBS6.8FLTIX

- Energy Rating A
- LED lighting
- 3 Extraction Speeds
- Silence Control
- Touch control
- 35 dBA



Code 869991634700
EAN 8003437624520

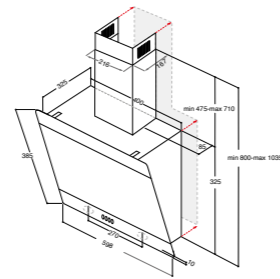

PHVP 62F LT K

- Energy Rating A
- LED lighting
- 3 Extraction Speeds
- Silence Control
- Touch Control



Code 869990949810
EAN 5016108949818

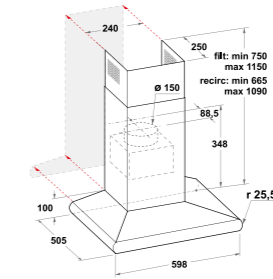

PHC6.7FLBIX

- Energy Rating B
- LED lighting
- 3 Extraction Speeds
- Booster
- Dishwasher-safe Grease Filters
- Timer



Code 869991553270
EAN 5054645553273

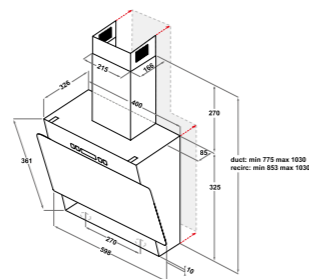

PHVP 6.4F AL K/1

- Energy Rating D
- LED lighting
- 3 Extraction Speeds
- Booster
- Dishwasher-safe Grease Filters
- Timer



Code 869991553600
EAN 5054645553600

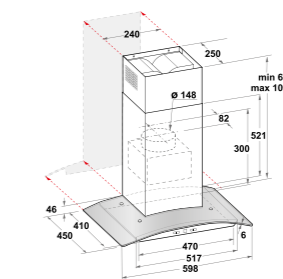

PHGC6.4 FLMX

- Energy Rating D
- LED lighting
- 3 Extraction Speeds
- Booster
- Dishwasher-safe Grease Filters



Code 869991557580
EAN 5054645557585

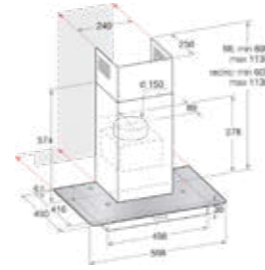

PHFG6.4FLMX

- Energy Rating D
- LED lighting
- 3 Extraction Speeds
- Booster
- Dishwasher-safe Grease Filters



Code 869991557410
EAN 5054645557417

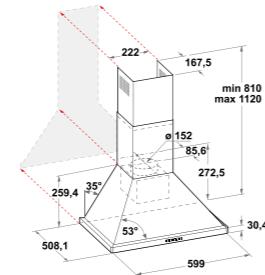

PHPN6.5 FMMX/1

- Energy Rating D
- LED lighting
- 3 Extraction Speeds
- Booster
- Dishwasher-safe Grease Filters



Code 869991562140
EAN 5054645562145

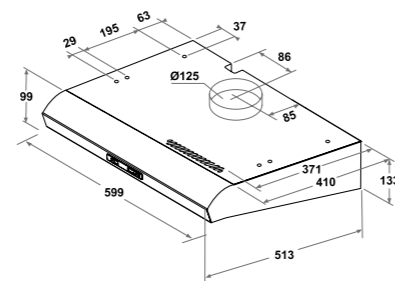

PSLMO 65F LS X

- Energy Rating D
- LED lighting
- 3 Extraction Speeds
- Dishwasher-safe Grease Filters



Code 869991562170
EAN 5054645562176

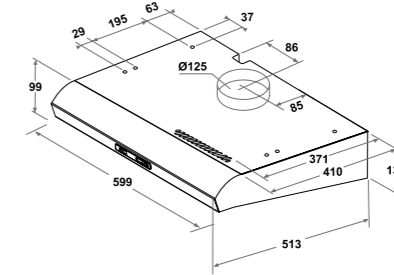

PSLMO 65F LS K

- Energy Rating D
- LED lighting
- 3 Extraction Speeds
- Dishwasher-safe Grease Filters



Code 869991559090
EAN 5054645559091

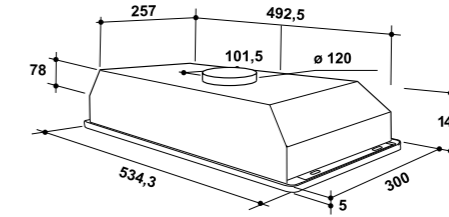

PCT 64 F LSS

- Energy Rating C
- LED lighting
- 4 Extraction Speeds
- Dishwasher-safe Grease Filters



Code 869991558410
EAN 5054645558414

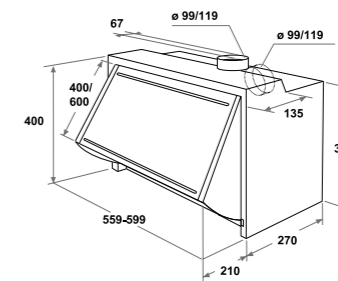

PAEINT 66F LS W

- Energy Rating D
- LED lighting
- 5 Extraction Speeds
- Dishwasher-safe Grease Filters

HOODS



Code 869991559300
EAN 5054645559305

HSFX.1/1

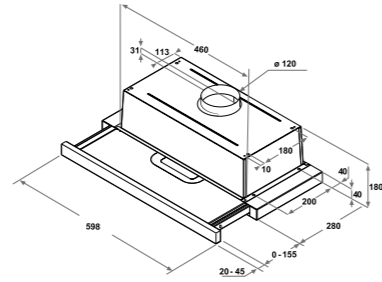

- * Energy Rating D
- * LED lighting
- * 6 Extraction Speeds
- * Dishwasher-safe Grease Filters



HOODS

	UIF 9.3F LB X	PHBS9.8CLTDK/1	PHGC9.4FLMX	PHPN9.5FLMX
SPECIFICATION				
DIMENSIONS (H x D x W mm)	690 x 898 x 451	700 x 898 x 506	1130 x 900 x 450	1120 x 900 x 509
ENERGY RATING	B	A	D	D
COLOUR	Inox/Glass	Black	Inox/Glass	Inox
MAXIMUM EXTRACTION SPEED (M³/H)	647 M ³ /H	550 M ³ /H	432 M ³ /H	432 M ³ /H
MAXIMUM EXTRACTION SPEED WITH BOOSTER (M³/H)	735 M ³ /H	680 M ³ /H	-	-
NOISE LEVEL (dBA)	70 dBA	72 dBA	65 dBA	62 dBA

TECHNOLOGY

RECIRCULATING FILTER INCLUDED	●	●	●	●
LED LIGHTING	●	●	●	●
CLEAN FILTER INDICATOR	●	●		
BUTTON CONTROL	●		●	●
TOUCH CONTROL		●		
SILENCE CONTROL	●	●		
BOOSTER	●	●		●
DISHWASHER-SAFE GREASE FILTERS	●	●	●	●
DUAL FILTER TECHNOLOGY		●		

HOODS

	PHVP 82F LT K	PHGC7.4FLMX	PHC7.7FLBIX	PHVP 62F LT K	PHVP 6.4F AL K/1	PHBS6.8FLTIX
SPECIFICATION						
DIMENSIONS (H x D x W mm)	430 x 360 x 326	1130 x 700 x 450	1150 x 700 x 500	430 x 360 x 326	381 x 595 x 293	1150 x 600 x 455
ENERGY RATING	A	D	B	A	D	A
COLOUR	Black	Inox/Glass	Inox	Black	Black	Inox/Black
MAXIMUM EXTRACTION SPEED (M³/H)	495 M ³ /H	432 M ³ /H	432 M ³ /H	495 M ³ /H	384 M ³ /H	420 M ³ /H
MAXIMUM EXTRACTION SPEED WITH BOOSTER (M³/H)	650 M ³ /H	-	713 M ³ /H	650 M ³ /H	-	720 M ³ /H
NOISE LEVEL (dBA)	65 dBA	65 dBA	60 dBA	65 dBA	63 dBA	62 dBA

HOODS

	PHC6.7FLBIX	PHGC6.4 FLMX	PHFG6.4FLMX	PHPN6.5 FLMX/1
SPECIFICATION				
DIMENSIONS (H x D x W mm)	1150 x 600 x 500	1130 x 600 x 450	1130 x 600 x 447	1120 x 600 x 508
ENERGY RATING	B	D	D	D
COLOUR	Inox	Inox/Glass	Inox/Glass	Inox
MAXIMUM EXTRACTION SPEED (M³/H)	432 M ³ /H	432 M ³ /H	432 M ³ /H	435 M ³ /H
MAXIMUM EXTRACTION SPEED WITH BOOSTER (M³/H)	713 M ³ /H	-	-	-
NOISE LEVEL (dBA)	60 dBA	65 dBA	65 dBA	60 dBA

TECHNOLOGY

RECIRCULATING FILTER INCLUDED	●	●	●	●	●	●	●	●	●
LED LIGHTING	●	●	●	●	●	●	●	●	●
CLEAN FILTER INDICATOR	●								
BUTTON CONTROL	●	●	●	●	●	●	●	●	●
TOUCH CONTROL									
SILENCE CONTROL	●								
BOOSTER	●								
DISHWASHER-SAFE GREASE FILTERS	●	●	●	●	●	●	●	●	●
DUAL FILTER TECHNOLOGY									

HOODS

	PSLMO 65F LS X	PSLMO 65F LS K	PCT 64 F L SS	PAEINT 66F LS W	HSFX.1/1
DIMENSIONS (H x D x W mm)	132 x 599 x 513	132 x 599 x 513	177 x 534 x 299	340 x 599 x 270	180 x 598 x 300
ENERGY RATING	D	D	C	D	D
COLOUR	Inox	Black	Inox	White	Inox
MAXIMUM EXTRACTION SPEED (M³/H)	208 M ³ /H	208 M ³ /H	224 M ³ /H	208 M ³ /H	304 M ³ /H
MAXIMUM EXTRACTION SPEED WITH BOOSTER (M³/H)	-	-	-	-	-
NOISE LEVEL (dBA)	71 dBA	71 dBA	54 dBA	65 dBA	62 dBA

HOTPOINT *dishwashers*

Hotpoint dishwashers quietly remove stubborn, baked-on food, so you can ditch the dishcloth.

Hotpoint



3D ZONE WASH



Tough ON GREASE,
gentle ON ENERGY

3D Zone Wash ensures precisely the right amount of water is used on the selected basket providing either 40% more cleaning power* for stubborn, baked-on foods, or 40% more energy efficiency** for smaller loads, depending on your needs.

* Average percentage of performance increase vs a non-3D Zone Wash appliance running Intensive cycle, obtained on 17 different items with different typology of dirt. Test results verified by VDE.

** Verified in the Report N° 236127-AS6-1 by VDE Test Institute.



ADJUSTABLE BASKETS & 3RD RACK

MAXIMUM *flexibility*
FOR YOUR LOADING NEEDS

Adjustable baskets and a removable third rack give you maximum flexibility when loading your dishwasher, letting you alter the set-up of the interior cavity's upper and lower baskets, creating space for larger pots and dishes.



SANITIZING CYCLE

MAXIMISE THE *hygiene*
OF YOUR DISHES

Maximise the hygiene of your dishes by eliminating 99.999%* bacteria with the sanitizing cycle.

*Tested and certified by VDE Prüf- und Zertifizierungsinstitut GmbH and Swissatest Testmaterialien AG.

GLASS CARE



SAY *goodbye*
TO WATER MARKS

Prevent water marks on your favourite glassware, with a dedicated cycle and specially designed glass holders. Simply fold away when not in use to maximise your space.

ACTIVEDRY



NATURALLY *air dry*
YOUR DISHES

ActiveDry naturally dries dishes by automatically opening the door of the dishwasher at the end of the cycle, delivering 60% better drying results*.

*Based on average drying performance of Hotpoint free-standing dishwasher with 3 racks and ActiveDry on combined load including plastics, glass, steel and porcelain as compared to Hotpoint free-standing dishwasher with 3 racks without ActiveDry. Drying performance results may vary based on dishwasher model and load.

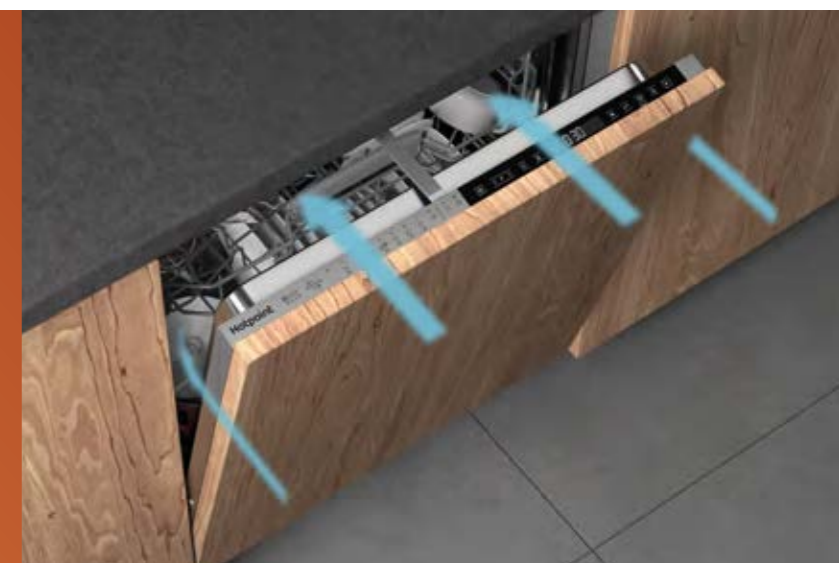



Code 869991600480
EAN 5054645600489

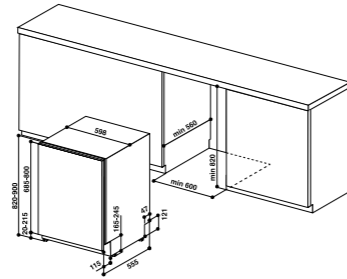

HIP 40539 WLEGT UK

- Energy Rating B
- 3D Zone Wash
- Active Dry
- Adjustable Basket + Cutlery Tray
- Super Silent
- Glass Care



Code 869991611510
EAN 5016108829141

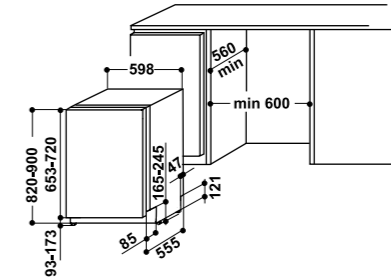

HIC 3B19 C UK

- Energy Rating F
- Eco Cycle
- Half Load
- Adjustable Basket + 1/2 Cutlery Tray
- Quick Wash 30'
- 12 L



Code 869991600470
EAN 5054645600472

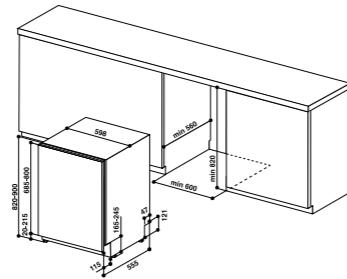

HIO 3T241 WFEGT UK

- Energy Rating C
- 3D Zone Wash
- Active Dry
- Adjustable Basket + Cutlery Tray
- Super Silent
- Glass Care



Code 869991618150
EAN 5054645618156

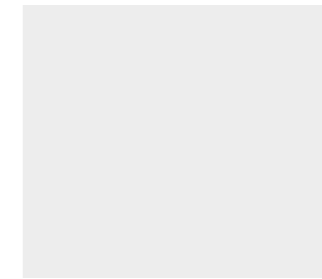

HIE 2B19 UK

- Energy Rating F
- Eco Cycle
- Intensive 65°
- Adjustable Basket
- 12 L



Code 869991601350
EAN 5054645601356

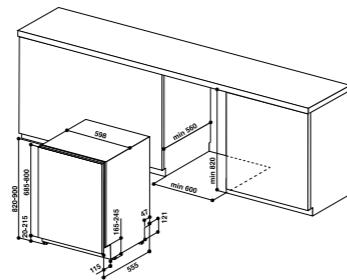

HIC 3C33 CWE UK

- Energy Rating D
- 3D Zone Wash
- Active Dry
- Adjustable Basket + 1/2 Cutlery Tray
- Sanitising Cycle
- Delay Timer



Code 869991616030
EAN 5054645569250

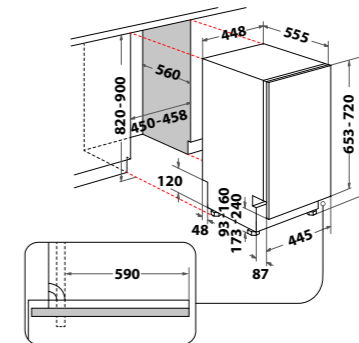

HSIC 3M19 C UK N

- Energy Rating F
- Eco Cycle
- Quick Wash 30'
- Adjustable Basket + 1/2 Cutlery Tray
- Delay Timer
- 11.5 L



Code 869991621090
EAN 5054645531424

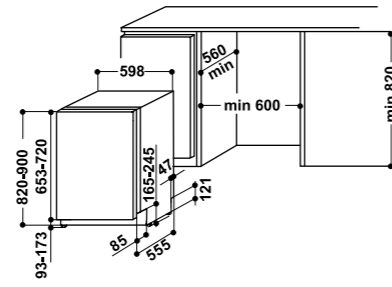

HIO 3P33 WLE UK

- * Energy Rating D
- * 3D Zone Wash
- * Active Dry
- * Adjustable Basket + Cutlery Tray
- * Sanitising Cycle
- * Delay Timer



Code 869991622820
EAN 5054645052233

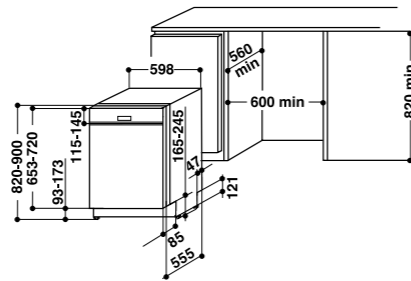

HBC 2B19 UK N

- * Energy Rating F
- * Eco Cycle
- * Half Load
- * Adjustable Basket
- * Quick Wash 30*
- * 12 L



Code 869991622840
EAN 5054645052240

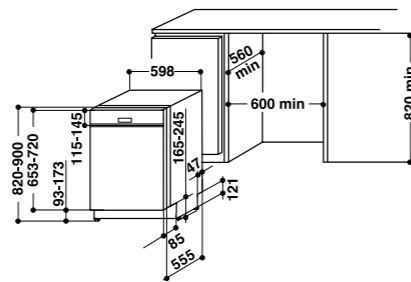

HBC 2B19 X UK N

- * Energy Rating F
- * Eco Cycle
- * Half Load
- * Adjustable Basket
- * Quick Wash 30*
- * 12 L



	HIP 40539 WLEGT UK	HIO 3T241 WFEGT UK	HIC 3C33 CWE UK	HIC 3B19 C UK
SPECIFICATION				
FULL SIZE (60CM)	●	●	●	●
SLIMLINE (45CM)				
PLACE SETTINGS	14	14	14	13
ENERGY RATING	B	C	D	F
COLOUR	S.Steel	S.Steel	Silver	Graphite
LITRES (L)	9.5 L	9.5 L	9.5 L	12 L
NOISE LEVEL (dBA)	39 dBA	41 dBA	43 dBA	49 dBA

TECHNOLOGY

3D ZONE WASH	●	●	●				●		
ACTIVE DRY	●	●	●				●		
GLASS CARE	●	●							
SANTITISING	●	●	●	●				●	
ADJUSTABLE BASKET	●	●	●	●		●	●	●	●
ADJUSTABLE BASKET + CUTLERY TRAY	●	●					●		
ADJUSTABLE BASKET + 1/2 CUTLERY TRAY			●	●		●			
QUICK WASH 30'	●	●	●	●		●	●	●	●
HALF LOAD				●				●	●
LIGHT ON FLOOR	●	●	●				●		
FOLD DOWN PLATE SUPPORTS	●	●	●	●			●		
DELAY TIMER	●	●	●	●		●	●	●	●
INVERTER MOTOR	●	●	●				●		
ECO CYCLE	●	●	●	●		●	●	●	●
INTENSIVE 65°	●	●	●	●		●	●	●	●

	HIE 2B19 UK	HSIC 3M19 C UK N	HIO 3P33 WLE UK	HBC 2B19 UK N	HBC 2B19 X UK N
FULL SIZE (60CM)	●		●		●
SLIMLINE (45CM)		●			
PLACE SETTINGS	13	10	13	13	13
ENERGY RATING	F	F	D	F	F
COLOUR	Silver	Silver	S.Steel	Black	S.Steel
LITRES (L)	12 L	11.5 L	11 L	12 L	12 L
NOISE LEVEL (dBA)	49 dBA	49 dBA	43 dBA	49 dBA	49 dBA



HOTPOINT *fridge freezers*

Thoughtful technology to help prevent food waste. Count on Hotpoint to take care of your fresh and frozen food.

Hotpoint

FRESH ZONE +

KEEP YOUR FRUIT AND VEGETABLES *tastier* FOR LONGER

The Fresh Zone+ drawer helps to maintain the right temperature, and features a handy humidity dial, so your fruit and vegetables stay crisp and full of flavour, for longer.



SPACE MANAGEMENT SYSTEM

Flexibility AT YOUR FINGER TIPS

Personalise your fridge by moving the shelves in the balcony and main compartment up and down to meet your storage needs.



ACTIVE FRESH

MAINTAIN THE IDEAL TEMPERATURE FOR LONG LASTING *food freshness*

This clever technology quickly restores temperature and humidity for optimal food preservation.



ACTIVE OXYGEN

REDUCE UP TO 99% OF *viruses and bacteria* WITH ACTIVE OXYGEN

Active Oxygen technology releases tri-oxygen molecules (O₃) into the fridge, neutralising unpleasant odours by up to 70% and reduces bacteria* and virus** growth by up to 99%. Active Oxygen is a molecule made up of 3 oxygen atoms – the same type that are present in nature and released into the atmosphere during a thunderstorm. Active Oxygen technology recreates this process inside your machine, so it doesn't need any refilling or maintenance when not in use.

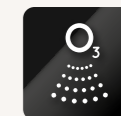

*ISO 9001-2001 certification. Tests performed by Sereco-Biotest Laboratory
**Virucidal field tests done by Natovir srl following the Guidance on the BPR, Vol. II Parts B+C, v. 3.0 Apr 2018 and including also Human Coronavirus OC43 for 24 hours at 4°C. Results referred to Murine Norovirus and Human Coronavirus OC43 and may vary based on shelf positioning and presence/absence of packaging. Tests on bacteria done by an independent laboratory on Petri plates in the 24 hours, according to ISO 22196, bacteria tested E.Coli and St. Aureus

TOTAL NO FROST NO SOGGY SALADS AND *never* DEFROST YOUR FRIDGE OR FREEZER *again*



Total No Frost technology consistently circulates air around both the fridge and freezer so moisture can't build up, which means no soggy salads and no ice build up, so you'll never have to defrost your fridge or freezer.



HTC20 T321 UK



Code 859991633680
EAN 5054645633685



- * Energy Rating F
- * Total No Frost
- * Active Fresh
- * Precision Temperature Control
- * Super Silent
- * Multicool Flow

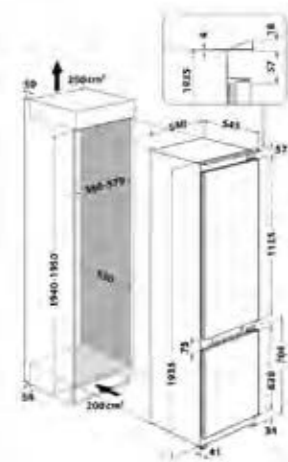

HTC18 T532 UK



Code 859991633670
EAN 5054645633678



- * Energy Rating E
- * Total No Frost
- * Active Fresh
- * Active Oxygen
- * Precision Temperature Control
- * Super Silent

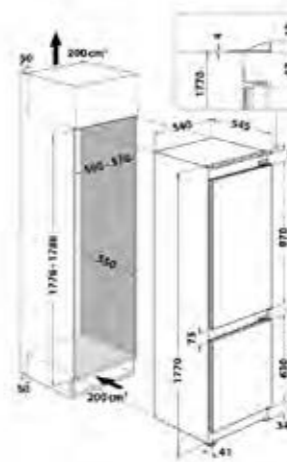

HTC18 T311 UK



Code 859991630770
EAN 5054645630776



- * Energy Rating F
- * Total No Frost
- * Active Fresh
- * Precision Temperature Control
- * Super Silent
- * Multicool Flow

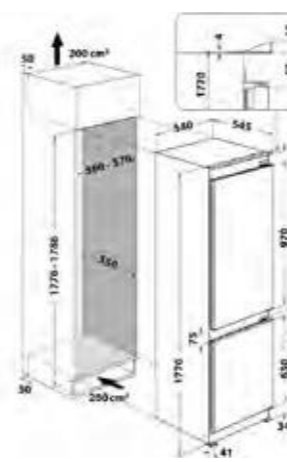

HBC18 5050 F1



Code 869991629530
EAN 5054645629534



- * Energy Rating F
- * No Frost
- * Fresh Zone+LED Lighting

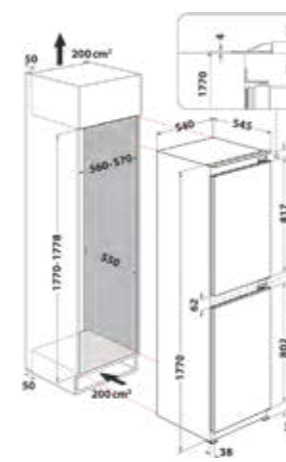

HMCB 50501 UK



Code 859991618560
EAN 5054645556731



- * Energy Rating F
- * Low Frost
- * Active Fresh
- * Fresh Zone
- * Flexible Space Management
- * LED Lighting

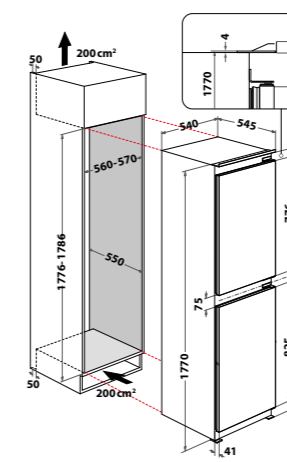

HMCB 70301 UK



Code 859991618050
EAN 5054645556724



- * Energy Rating F
- * Low Frost
- * Active Fresh
- * Fresh Zone
- * Flexible Space Management
- * LED Lighting

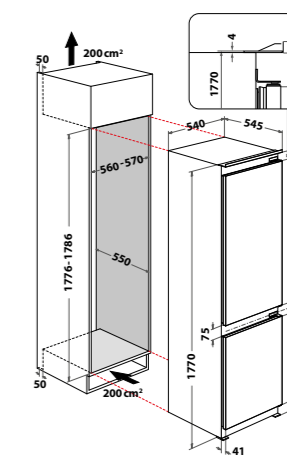

JPEG ICON
Can this be
resupplied as
a Vector file
(EPS)?

JPEG ICON
Can this be
resupplied as
a Vector file
(EPS)?

HL A1.UK 1



Code 859991607420
EAN 5054645556052



- * Energy Rating F
- * Low Frost
- * Fresh Zone
- * Space Management System
- * LED Lighting

HF A1.UK 1



Code 859991601580
EAN 5054645556113



- * Energy Rating F
- * Low Frost
- * Fresh Zone
- * Space Management System
- * LED Lighting

HS 18011 UK



Code 859991613340
EAN 5054645556083



- * Energy Rating F
- * Low Frost
- * Active Fresh
- * Dual Fresh Zone
- * Space Management System
- * LED Lighting

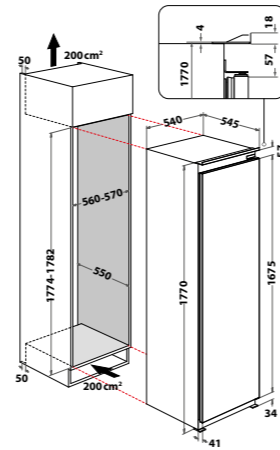
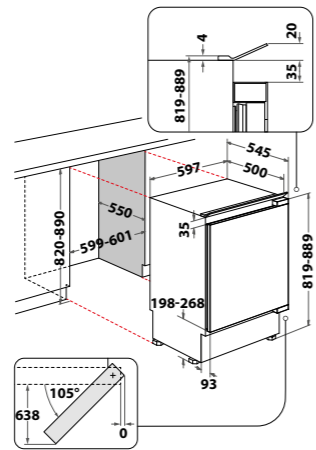
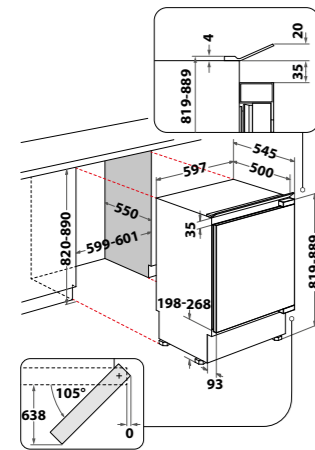

HSZ 18011 UK



Code 859991607350
EAN 5054645556106



- * Energy Rating F
- * Low Frost
- * Active Fresh
- * Dual Fresh Zone
- * Space Management System

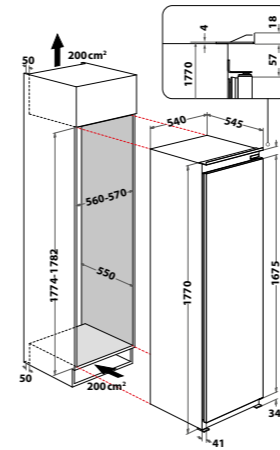

HS 12 A1 D.UK 1



Code 859991601750
EAN 5054645556199



- * Energy Rating F
- * Low Frost
- * Active Fresh
- * Fresh Zone
- * Space Management System
- * LED Lighting

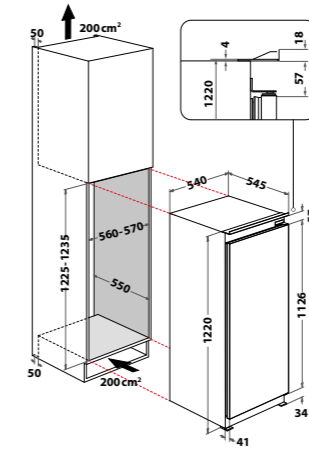

HSZ 12 A2D.UK 1



Code 859991614750
EAN 5054645556304



- * Energy Rating F
- * Low Frost
- * Active Fresh
- * Fresh Zone
- * Space Management System

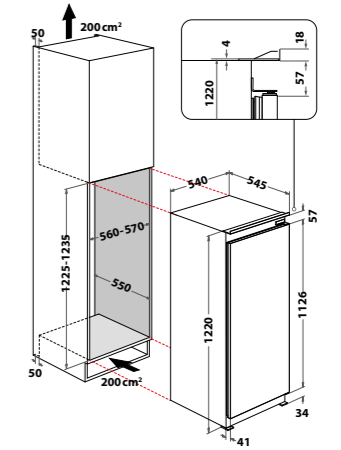

HZ A1.UK 1

HF 1801 E F1 UK



Code 859991604220
EAN 5054645556335



- * Energy Rating F
- * Low Frost
- * 27 Hour Power Safe
- * 2 Drawers And 1 Flap

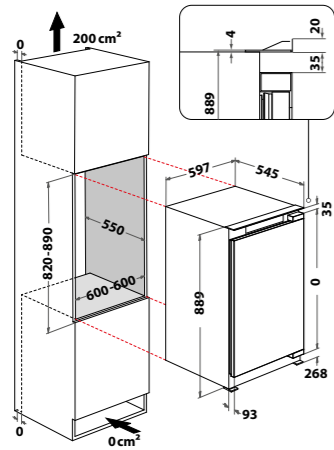

Code 859991613720
EAN 5054645556328



- * Energy Rating F
- * No Frost
- * Fast Freeze Function
- * 23 Hour Power Safe
- * Open Door Indicator
- * LED Strip Lighting

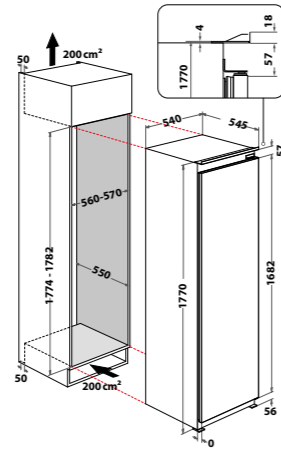

COOLING

	HTC18 T532 UK	HTC20 T321 UK	HTC18 T311 UK	HBC18 5050 F1
SPECIFICATION				
FREEZER NET CAPACITY (L)	68	68	68	85
FRIDGE NET CAPACITY (L)	182	212	182	145
TOTAL CAPACITY (L)	250	280	250	230
HEIGHT (CM)	177	194	177	177
ENERGY RATING	E	F	F	F
NOISE (DB)	34	34	34	38
TOTAL ANNUAL ENERGY CONSUMPTION (KWH)	224	278	280	290
NUMBER OF FRIDGE SHELVES	5	6	5	4
NUMBER OF FREEZER COMPARTMENTS	3	3	3	4
TYPE OF DISPLAY	Digital	LED	LED	Mechanical

TECHNOLOGY

TOTAL NO FROST TECHNOLOGY	●	●	●	
NO FROST TECHNOLOGY				●
LOW FROST				
ACTIVE OXYGEN	●			
ACTIVE FRESH	●	●	●	
FRESH ZONE+	●	●	●	●
FRESH ZONE	●	●		
DUAL FRESH ZONE				
FLEXIBLE SPACE MANAGEMENT	●	●	●	
SPACE MANAGEMENT SYSTEM				●
BOTTLE RACK		●		
EASY FIND TRAY	●	●	●	
OPEN DOOR INDICATOR	●	●	●	
TEMPERATURE ALARM	●	●	●	
MULTIFRESH ZONE		●		
PRECISION TEMPERATURE CONTROL	●	●	●	
SUPER SILENT	●	●	●	

COOLING

	HMCB 50501 UK	HMCB 70301 UK	HLA1.UK 1	HF A1.UK 1	HS 18011 UK	HSZ 18011 UK
FREEZER NET CAPACITY (L)	109	79	-	18	-	30
FRIDGE NET CAPACITY (L)	154	194	144	108	314	262
TOTAL CAPACITY (L)	263	273	144	126	314	292
HEIGHT (CM)	177	177	81.5	81.5	177	177
ENERGY RATING	F	F	F	F	F	F
NOISE (DB)	35	35	37	38	35	35
TOTAL ANNUAL ENERGY CONSUMPTION (KWH)	310	299	118	179	147	280
NUMBER OF FRIDGE SHELVES	3	4	3	2	6	5
NUMBER OF FREEZER COMPARTMENTS	3	3	-	1	-	1
TYPE OF DISPLAY	LED	LED	Mechanical	Mechanical	LED	LED

TOTAL NO FROST TECHNOLOGY						
NO FROST TECHNOLOGY						
LOW FROST	●	●	●	●	●	●
ACTIVE OXYGEN						
ACTIVE FRESH						
FRESH ZONE+						
FRESH ZONE	●	●	●	●		
DUAL FRESH ZONE					●	●
FLEXIBLE SPACE MANAGEMENT	●	●			●	
SPACE MANAGEMENT SYSTEM				●	●	
BOTTLE RACK					●	●
EASY FIND TRAY						
OPEN DOOR INDICATOR						
TEMPERATURE ALARM						
MULTIFRESH ZONE						
PRECISION TEMPERATURE CONTROL						
SUPER SILENT						

COOLING

	HS 12 A1 D.UK 1	HSZ 12 A2D.UK 1	HZA1.UK 1	HF 1801 E F1 UK
SPECIFICATION				
FREEZER NET CAPACITY (L)	-	18	91	209
FRIDGE NET CAPACITY (L)	209	172		-
TOTAL CAPACITY (L)	209	190	91	209
HEIGHT (CM)	122	122	81.5	177
ENERGY RATING	F	F	F	F
NOISE (DB)	35	36	38	38
TOTAL ANNUAL ENERGY CONSUMPTION (KWH)	132	217	185	307
NUMBER OF FRIDGE SHELVES	5	4	-	-
NUMBER OF FREEZER COMPARTMENTS	-	1	3	8
TYPE OF DISPLAY	LED	LED	Mechanical	Digital
TECHNOLOGY				
TOTAL NO FROST TECHNOLOGY				
NO FROST TECHNOLOGY				
LOW FROST	●	●	●	●
ACTIVE OXYGEN				
ACTIVE FRESH				
FRESH ZONE+				
FRESH ZONE	●	●		
DUAL FRESH ZONE				
FLEXIBLE SPACE MANAGEMENT	●	●		
SPACE MANAGEMENT SYSTEM				
BOTTLE RACK				
EASY FIND TRAY				
OPEN DOOR INDICATOR	●	●		
TEMPERATURE ALARM				
MULTIFRESH ZONE				
PRECISION TEMPERATURE CONTROL				
SUPER SILENT				



WASHING MACHINES *and* WASHER DRYERS

Hotpoint



WOOL CARE



Soft AND gentle CARE FOR YOUR WOOLLENS

Trust Hotpoint to provide the utmost care for your woollens with a delicate wash programme that ensures a perfect clean whilst protecting the softness of the fabric.



WASH & DRY 45°



TOTAL LAUNDRY *convenience*

Achieve total laundry convenience - wash and dry a load of laundry in just 45 minutes.

ANTISTAIN QUICK



REMOVE EVERYDAY STAINS IN JUST *45 minutes*

This rapid 45 minute cycle removes common, everyday stains, without the need to pre-treat your clothes, so you can leave the laundry to Hotpoint, knowing your fabrics will be protected and look like new.



ANTISTAIN



Every day STAIN REMOVAL

A dedicated Antistain programme that easily eliminates common stains from your clothes without the need for pre-treatment. The machine innovatively controls the correct amount of water, temperature level, detergent and drum movements, so you can say goodbye to stains.



Code 869991586300
EAN 5054645586301

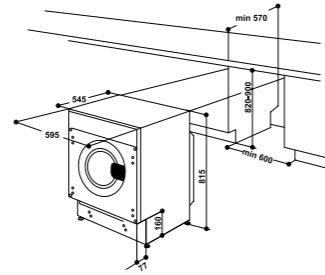

BI WMHG 91484 UK

- Energy Rating C
- Anti-Stain 40° Cycle
- Anti-Stain Quick Cycle
- Wool Care
- Rapid 30' Cycle
- Delicate Cycle



Code 869991586180
EAN 5054645586189

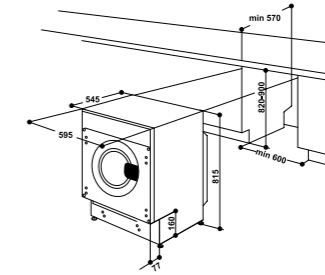

BI WDHG 961484 UK

- Energy Rating D/C
- Anti-Stain 40° Cycle
- Anti-Stain Quick Cycle
- Steam Refresh
- Wash & Dry 45' Cycle
- Wool Care



Code 869991586310
EAN 5054645586318

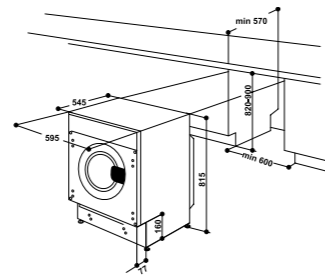

BI WMHG 81484 UK

- Energy Rating C
- Anti-Stain 40° Cycle
- Anti-Stain Quick Cycle
- Wool Care
- Rapid 30' Cycle
- Delicate Cycle



Code 869991586000
EAN 5054645586004

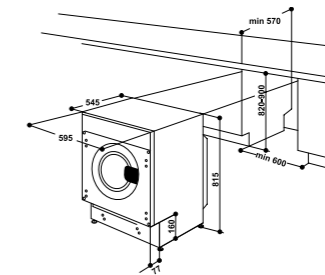

BI WDHG 861484 UK

- Energy Rating D/C
- Anti-Stain 40° Cycle
- Anti-Stain Quick Cycle
- Steam Refresh
- Wash & Dry 45' Cycle
- Wool Care



Code 869991602970
EAN 5054645602971

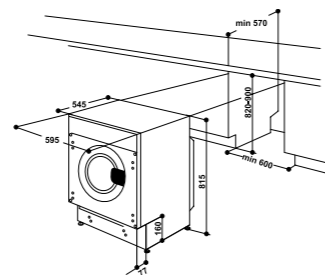

BI WMHG 71483 UK N

- Energy Rating D
- Anti-Stain 40° Cycle
- Anti-Stain Quick Cycle
- Wool Care
- Rapid 30' Cycle
- Delicate Cycle

	BI WMHG 91484 UK	BI WMHG 81484 UK	BI WMHG 71483 UK N	BI WDHG 961484 UK	BI WDHG 861484 UK
SPECIFICATION					
CAPACITY (kg)	9	8	7	9+6	8+6
SPIN SPEED (rpm)	1400	1400	1400	1400	1400
ENERGY RATING	C	C	D	D C	D C
DIMENSIONS (H x D x W mm)	820 x 545 x 595	820 x 545 x 595	820 x 545 x 595	820 x 545 x 595	820 x 545 x 595
COLOUR	White	White	White	White	White
NOISE dB(A)	70	70	72	70	70
ADJUSTABLE FEET	●	●	●	●	●
TECHNOLOGY					
ANTI STAIN 40° CYCLE	●	●	●	●	●
ANTI STAIN QUICK CYCLE	●	●	●	●	●
RAPID 30' QUICK CYCLE	●	●	●	●	●
WOOL CARE	●	●	●	●	●
ENERGY SAVER OPTION	●	●	●	●	●
CHILD LOCK	●	●	●	●	●
START DELAY	●	●	●	●	●
MULTI RINSE OPTION	●	●	●		
CLEANING ACTION OPTION	●	●	●		
STEAM REFRESH				●	●
DRY ONLY OPTION				●	●
DRYNESS LEVEL SETTING				●	●
WASH & DRY 45' CYCLE				●	●
PRE IRON CYCLE				●	●

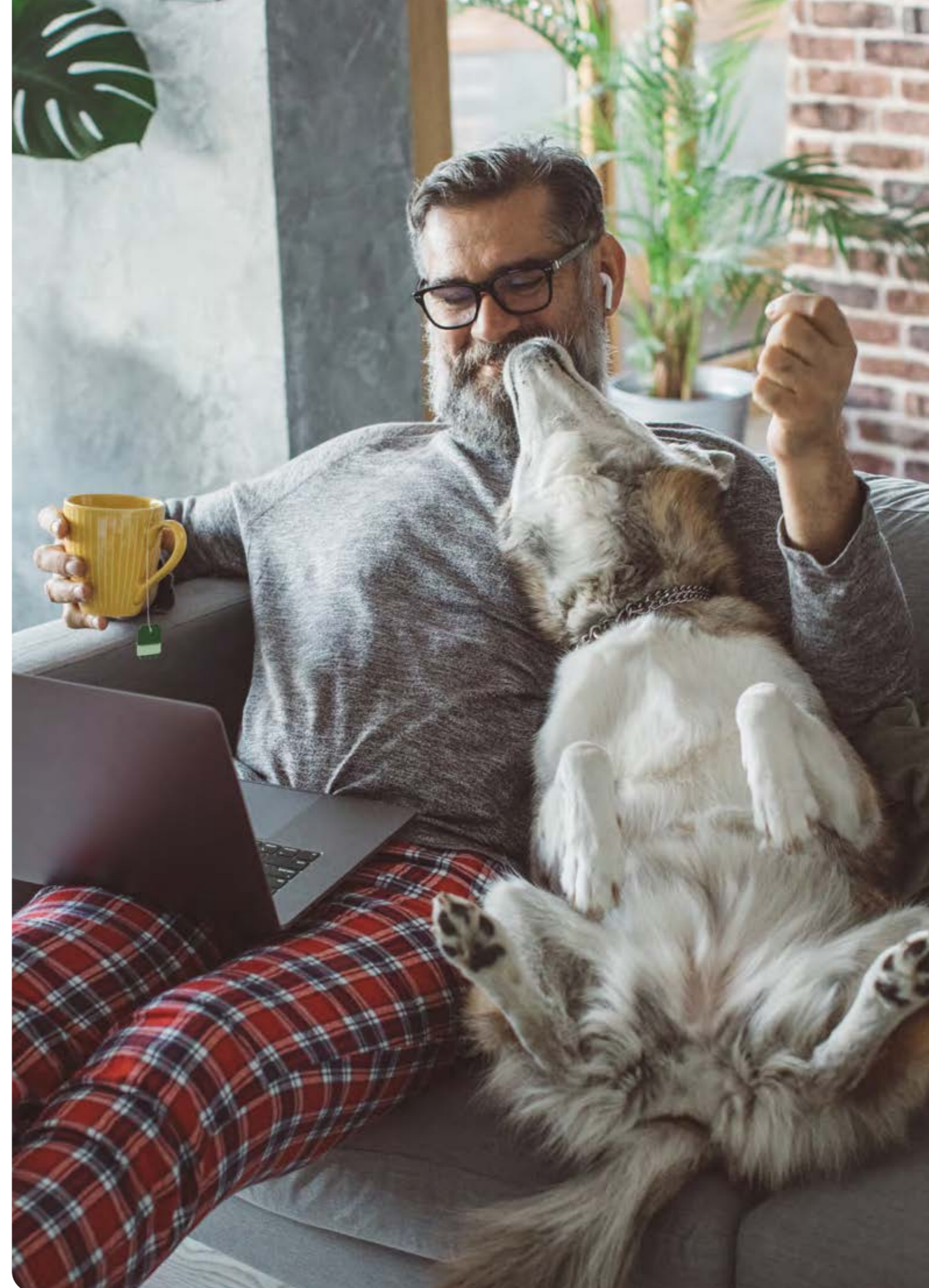

HOTPOINT CARE

Quality at the heart of all we do

OUR APPLIANCE LEAVING THE FACTORY ISN'T THE END OF THE STORY. FOR US IT'S JUST THE START OF A WHOLE NEW CHAPTER.

At every stage of the creation of our appliances, everyone's job is to always achieve the highest possible quality standards. This has shaped our history and success that we always strive to build on. From design to material selection, from production to after sales service, our objective is to keep our appliances working perfectly. New products are tested to simulate 10 years of use - that's the equivalent to thousands of hours and we're so confident in the quality and reliability of Hotpoint appliances, we even offer replacement parts free for the first 10 years.



GUARANTEED PARTS FOR 10 YEARS ON LARGE APPLIANCES

Your Hotpoint appliance is covered for a full 12 months by our own parts and labour warranty. In addition, when you register your appliance we also provide free parts for the first 10 years when fitted by our highly qualified engineers. Please call **0800 597 8520** to register today. (For the Republic of Ireland please call **012 300 233**).

REGISTER MY APPLIANCE

Hotpoint is proud to support the Register My Appliance initiative

WHY REGISTER YOUR APPLIANCE?

- Allows us to contact you in the event of an important product update
- Gives us full details of the products you own, should you need to contact us
- Whether old or new we would like to know which Hotpoint appliances you have

HOW TO GET THE BEST OUT OF YOUR APPLIANCE

At Hotpoint we design and manufacture our appliances to provide many trouble-free years of service to our customers, but there are also a few things you can do yourself to help ensure your appliance operates to its full potential.

To find out visit www.hotpointservice.co.uk

WE'RE HERE IF YOU EVER NEED US,
call us on 03448 224 224

Hotpoint Service is second to none. We are open when you need us and our operators are on hand 364 days a year to answer your call on **03448 224 224** (For the Republic of Ireland please call **0818 313 413**).

For more information, please visit hotpointservice.co.uk

LOCAL ENGINEERS NATIONWIDE

We are the largest white goods service team in the United Kingdom & Republic of Ireland, with over 1000 locally based Hotpoint engineers. These fully trained Hotpoint specialists will ensure you receive fast, reliable and local service.

APPOINTMENTS TO SUIT YOU

We do everything possible to fit in with your busy lifestyle, including flexibility of appointment times. Saturday appointments are also available in some areas. We will send you a text message with a 3 hour time slot on the evening before your appointment.

PROFESSIONAL WORKMANSHIP - BY THE EXPERTS

Our engineers are professionally trained at the Hotpoint School of Excellence and receive continuous training to ensure they are up-to-date with the latest products. We only fit genuine Hotpoint replacement parts and guarantee our repair work for a full 12 months.

YOUR PEACE OF MIND WITH TOTAL PROTECTION

We offer fast, quality repairs and protection plan options for complete peace of mind. Hotpoint appliances come with a full 12 months manufacturer's guarantee. Extra peace of mind is also available with a Hotpoint care plan, which offers repair and protection for your home appliances.

SATISFACTION GUARANTEED

Within the first 28 days of ownership we have a dedicated team who provide fast track product advice and assistance to deal with your enquiries quickly and efficiently. In the unlikely event that a technical problem occurs that cannot be resolved in this period we will replace your appliance.

Specifications and technical information are subject to change at any time. While every effort has been made to ensure that the information contained in this brochure is correct at time of going to press, Hotpoint cannot be held responsible for any errors or omissions that may come to light after publication. Products offered for sale may differ from those described or illustrated herein and Hotpoint reserves the right to alter specifications without prior notice. Due to printing limitations the colour of appliances illustrated herein cannot be guaranteed accurate and should be used for guidance only. If particular features, colours or measurements are important to you please check with your Hotpoint dealer before purchasing.

hotpoint.co.uk